

ENERGY RECOVERY VENTILATOR

VENMAR AVS DUO 1.2

Part #43710 Canada/US

64 to 117 CFM (0.4 in. w.g.)



VB0008

THE «HEALTH CONSCIOUS» SYSTEM THAT IS RIGHT FOR YOU

Designed to provide clean air all year round, the AVS DUO is particularly intended for customers with health concerns. Airborne bacteria, mites and allergens such as dust, pollen and mold are removed. Combined with an optional filter that can be inserted in the unit, the AVS DUO is the perfect ventilation system that provides a healthier indoor environment. The AVS DUO is also the prime choice to work in combination with an air conditioning unit.

- Reversible unit installation
- Improved standard filter performance
- Unique pan design, easier to clean and maintain
- Integrated balancing dampers and pressure taps
- Polymeric enthalpy wheel: recovers heat and humidity
- No drain
- Exclusive HomeShield™ patented defrost system
- SilentSure™ operation
- PSC motor

REPAIRS AND MAINTENANCE

Venmar AVS DUO modular design makes it possible to remove all mechanical parts in less than 5 minutes. The recovery wheel and its driving mechanism are characterized by their simplicity and ease of maintenance. Resorting to proven technologies, the Venmar development team applied the principle of the belt-driven system used in cars and used a shock and vibration-absorbing axle to prevent wear on the motor.

The low power consumption PSC motor is permanently lubricated. Even better, the entire motor subassembly can be removed in less than a minute for easier maintenance. Finally, the electronic circuit board eliminates electromechanical parts, reducing repair time to a minimum.

WARRANTY

The Venmar AVS DUO is fully protected by a 5-year warranty including the energy recovery thermal wheel. We are so confident in our product that we also offer a 90-day in-home warranty on parts and service.

Available at:

Controls

- Built-in electronic circuit board ready to receive one of the following main controls:
 - ULTIMA #40340 - *Ideal for this system*
 - VENTA #40310
 - SUPRA #40320
- One or more of the following optional controls can be added:
 - Humidity Control #11297
 - 20-min. lighted push button #12030
 - 60-min. mechanical timer #00910
 - 20/40/60-minute push button #03364
 - Wireless 20-minute remote control #03366

Options

- Complete line of registers and diffusers
- Electric duct heater
- Filters:
 - Charcoal #03315
 - Pleated #03316
 - Electronic #03314

HomeShield™ Defrosting System

The AVS DUO uses a unique defrosting method. No negative pressure is created by air exhausted to the outside, as the air is recirculated into the house, thus avoiding any backdraft from the chimney. Moreover, this defrosting method by air circulation ensures that no shortage of air is created for combustion units.

OUTSIDE TEMPERATURE °C	DEFROST CYCLE defrosting min. / operating min.
-5 TO -15	9/60
-15 TO -27	9/32
-27 & LESS	9/20

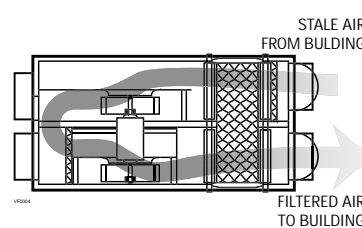

Energy Recovery Wheel

Dimensions: 14" ø x 3-3/4" (35.6 cm ø x 9.5 cm)

Weight: 5.5 lbs (2.5 kg)

Material: Polymeric wheel impregnated with desiccant

Type: Thermal wheel

Warranty: 5-year warranty

Requirements and Standards

- Complies with the UL 1812 requirements regulating the installation of Heat Recovery Ventilators.
- Complies with the CSA C22.2 #113 Standard applicable to ventilators.
- Complies with the CSA C444 requirements regulating the installation of Energy Recovery Ventilators.
- Technical data was obtained from published results of tests relating to CSA C439 Standards.
- HVI certified.

Dimensions and Service Clearances: Venmar AVS DUO 1.2

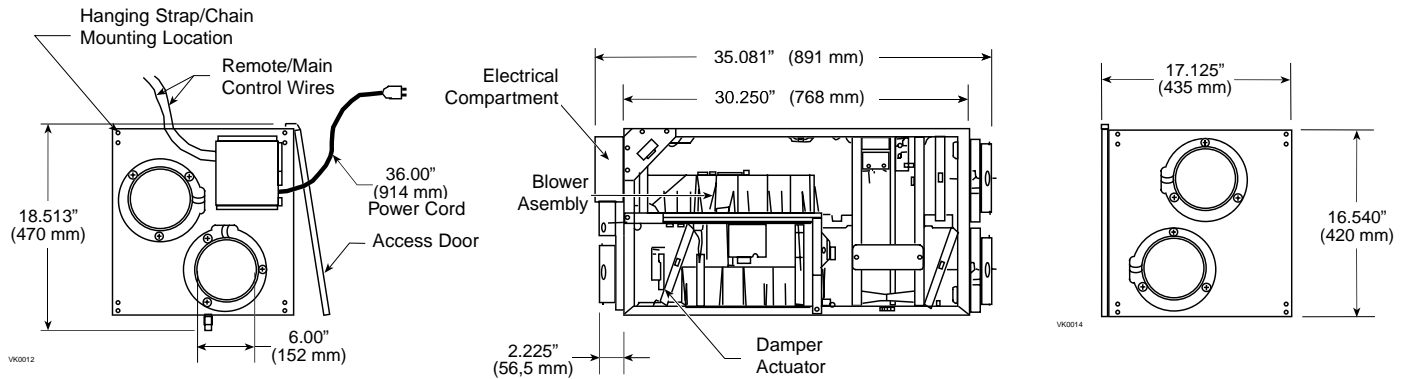

Ventilation Performance

EXT. STATIC PRESSURE	NET SUPPLY AIR FLOW			GROSS AIR FLOW							
	Pa	in.w.g.	l/s	cfm	m ³ /h	SUPPLY		EXHAUST			
25	.1	62	131	223	62	133	223	64	137	230	
50	.2	59	125	212	60	127	216	61	130	220	
75	.3	58	123	209	58	124	209	58	123	209	
100	.4	54	114	194	55	116	198	55	117	198	
125	.5	51	108	184	52	110	187	50	107	180	
150	.6	45	95	162	45	96	162	47	99	169	
175	.7	39	83	140	39	84	140	40	85	144	
200	.8	31	65	112	31	66	112	29	62	104	

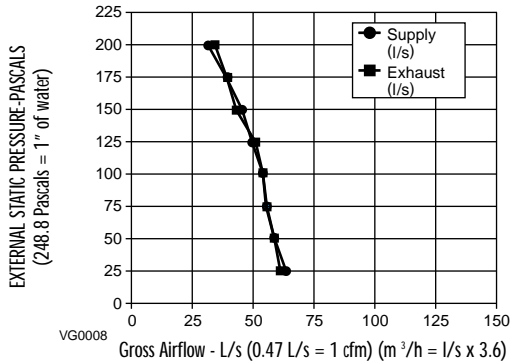

Energy Performance

SUPPLY TEMPERATURE		NET AIR FLOW		POWER CONSUMED WATTS	SENSIBLE RECOVERY EFFICIENCY	APPARENT SENSIBLE EFFECTIVENESS	LATENT RECOVERY / MOISTURE TRANSFER
C°	F°	l/s	cfm				
HEATING							
0	+32	32	68	115	108	77	87
0	+32	56	119	202	156	71	81
0	+32	---	---	---	---	---	---
-25	-13	51	108	184	189	66	82
-25	-13	---	---	---	---	---	---
COOLING							
+35	+95	31	66	112	103	TOTAL RECOVERY EFFICIENCY	
+35	+95	---	---	---	---	75	

NOTE: All specifications are subjected to change without notice.

Specifications and Ratings

- Model: Venmar AVS DUO 1.2
- Part Number: #43710 Canada/US
- Total Assembled Weight:
 - (Including energy recovery wheel) 68 lbs (31 Kg)
- Supply Air Duct Connections: 6" (15.24 cm) diameter
- Exhaust Air Duct Connections: 6" (15.24 cm) diameter
- Filters: -20 ppi washable reticulated foam
 - 15.375" x 7.125" x 0.75"
 - (39 x 18 x 1.9 cm)
- Cabinet: 20 ga. pre-painted steel
- Insulation: 1" (2.54 cm) aluminium foil faced fiberglass, 0.825" (2.10 cm) expanded polystyrene
- Mounting: suspension by chains and springs
- Supply & Exhaust Blower Motor: 1 motor
 - Protection type: Thermally protected
 - Insulation class: B
 - Motor marking: 120 V ac, 50/60 Hz, 1.2/1.0 A, 1050/1300/1660 RPM
- Fan Speed Control: -Low or increased low & high speed.
 - Two speeds available for the user.
 - Low or increased low speed is selected at the time of installation.
- Unit Electrical Characteristics:

	Volt	Freq	Amperes	Watts
Canada/US	120	60 Hz	1.4	160

Submitted by:		Date:	Project:
Qty:	Model #:	Remarks:	Location:
			Architect:
			Engineer:
			Contractor:

