



APPLIES TO: **Venting Requirements for Model UDAS and Model UDBS and Instructions for Combustion Air Inlet / Vent Terminal Options CC6 and CC2**

General

This manual applies only to venting and combustion air inlet instructions and **must be used with the installation manual that was shipped with the heater.** If either manual is missing, contact your distributor before beginning installation.

Verify that the label near the vent outlet on the heater matches the label illustrated below. (Label P/N is 201216; color is green.)

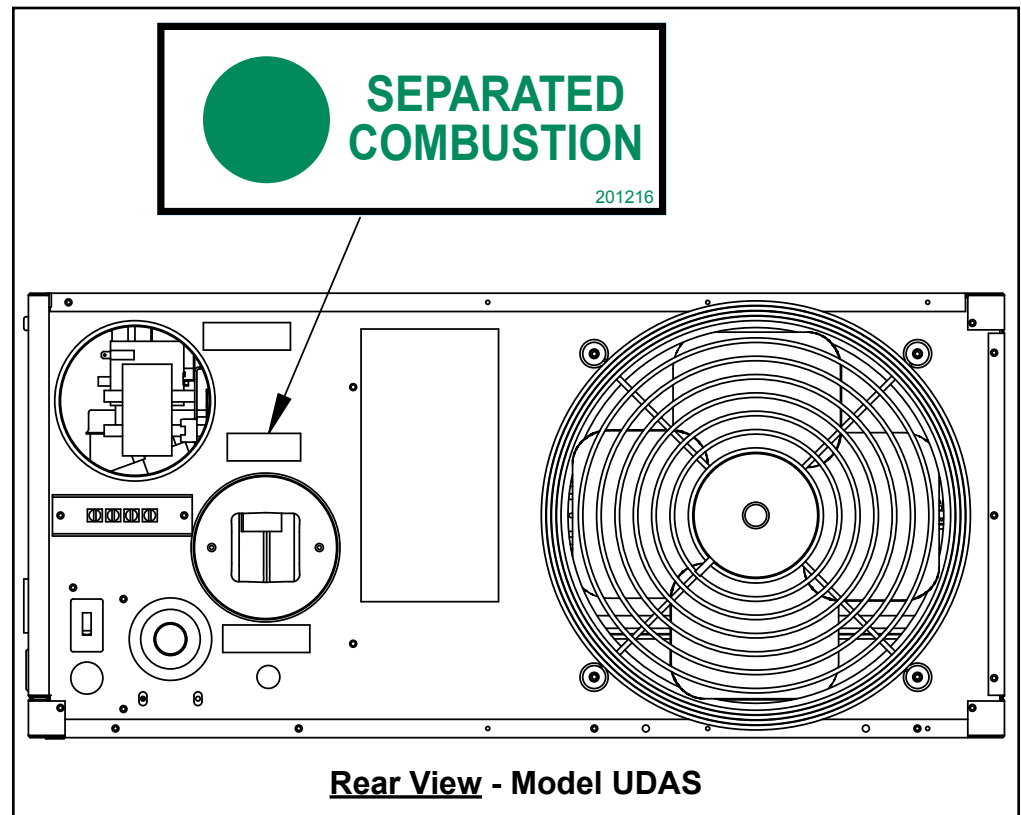

WARNING: Installation should be done by a qualified agency in accordance with these instructions. The qualified service agency installing this separated-combustion system is responsible for the installation.

WARNING: Do not use an existing venting system. This heater requires installation of the combustion air/vent system ordered with the unit, either Option CC6 or CC14 for a horizontal system or Option CC2 for a vertical system. Failure to comply could result in severe personal injury or death and/or property damage.

Table of Contents

General	1
1. Venting and Combustion Air Requirements for Separated Combustion Models UDAS and UDBS	2
1.1 Type of Pipe	3
1.2 Venter Outlet and Combustion Air Inlet	4
1.3 Pipe Diameter and Length	4
1.4 Joints and Sealing	5
1.5 Support.....	6
1.6 Condensation.....	7
1.7 Clearance.....	7
1.8 Concentric Adapter Box	7
2. HORIZONTAL VENT INSTRUCTIONS - <u>Option CC6</u>.....	10
2.1 Components Required - Factory and Field	10
2.2 Installation Instructions for Horizontal Vent/Combustion Air Kit Option CC6 (in compliance with requirements on pages 3-9)	11
3. VERTICAL VENT INSTRUCTIONS - <u>Option CC2</u>	14
3.1 Components Required - Factory and Field	14
3.2 Installation Instructions for Vertical Vent/Combustion Air Kit Option CC2 (in compliance with requirements on pages 3-9)	15
INDEX.....	20

1. Venting and Combustion Air Requirements for Separated Combustion Models UDAS and UDBS

All separated combustion units **MUST BE** equipped with both combustion air and exhaust piping to the outdoors. The unique concentric adapter assembly required with this heater allows for both combustion air and exhaust piping with only one horizontal or vertical penetration hole in the building.

When an existing appliance is removed or replaced in a venting system, the venting system may not be properly sized to vent the attached appliances. An improperly sized venting system may result in the formation of condensate, leakage, and/or spillage.

Concentric horizontal and vertical vent/combustion air systems are the only venting/combustion air systems approved for Model UDAS and Model UDBS separated-combustion unit heaters.

Model UDAS 30, 45, 60, 75, 100, and 125 are certified for both residential and commercial/industrial installations. Utility heaters certified for “residential use” are intended for heating of non-living spaces that are attached to, or part of, a structure that contains space for family living quarters. They are not intended to be the primary source of heat in residential applications or to be used in sleeping quarters.

Model UDAS 150, 175, 200, 225, 250, 300, 350, and 400 and Model UDBS 30, 45, 60, 75, 100, 125, 150, 175, 200, 225, 250, 300, 350, and 400 are certified only for commercial/industrial installations.

The presence of chlorine vapors in the combustion air of gas-fired heating equipment presents a potential corrosion hazard. Chlorine found usually in the form of freon or degreaser vapors, when exposed to flame will precipitate from the compound, and go into solution with any condensation that is present in the heat exchanger or associated parts. The result is hydrochloric acid which readily attacks all metals including 300 grade stainless steel. Care should be taken to separate these vapors from the combustion process. This may be done by wise location of the combustion air terminal with regard to exhausters or prevailing wind directions. Chlorine is heavier than air. Keep these facts in mind when determining installation location of the heater in relation to building exhaust systems.

Hazards of Chlorine

Is the Installation Residential or Commercial/Industrial?

The requirements in Venting Requirement 1.1, Type of Vent Pipe, are not the same for Residential and Commercial/Industrial installations. Other venting requirements (1.2 through 1.8) are the same for both.

The installation instructions in Paragraphs 2 and 3 apply to both residential and commercial/industrial installations.

The testing requirement in Paragraph 4 applies to a residential installation.

Read the headings and comply with the requirements that apply to the type of installation.

1.1 Type of Pipe

All pipe is field supplied. Select installation type that applies. Requirements are listed for both the vent pipe and the combustion air inlet pipe.

1.1.1 Residential Installation - Pipe Requirements
NOTE: Only UDAS 30, 45, 60, 75, 100, and 125 are certified for residential use.

Horizontal or Vertical Vent Pipe Run

- Vent pipe approved for a Category III appliance is **required between the heater and the concentric adapter box.**

Horizontal Vent Terminal (using Option CC6 Kit)

- Vent pipe approved for a Category III appliance **OR** single-wall, 26-gauge or heavier galvanized (or a material of equivalent durability and corrosion resistance) vent pipe is **required for the horizontal vent terminal** section. The length of vent pipe that extends through the box and runs concentric through the combustion air pipe must be one-piece with no joints.

Vertical Vent Terminal (using Option CC2 Kit)

- Double-wall (Type B) vent pipe is **required for the vertical vent terminal** section. The length of vent pipe that extends through the box and runs concentric through the combustion air pipe must be one-piece with no joints.

Combustion Air Inlet Pipe

- Sealed, single-wall galvanized pipe is recommended for vent run and terminal combustion air pipe.

1.1.2 Commercial/Industrial Installation - Pipe Requirements

Horizontal or Vertical Vent Pipe Run

- Vent pipe approved for a Category III appliance **OR** single-wall, 26-gauge or heavier galvanized (or a material of equivalent durability and corrosion resistance) vent pipe is **required between the heater and the concentric adapter box.**

Horizontal Vent Terminal (using Option CC6 Kit)

- Vent pipe approved for a Category III appliance **OR** single-wall, 26-gauge or heavier galvanized (or a material of equivalent durability and corrosion resistance) vent pipe is **required for the horizontal vent terminal** section. The length of vent pipe that extends through the box and runs concentric through the combustion air pipe must be one-piece with no joints.

Vertical Vent Terminal (using Option CC2 Kit)

- Double-wall (Type B) vent pipe is **required for the vertical vent terminal** section. The length of vent pipe that extends through the box and runs concentric through the combustion air pipe must be one-piece with no joints.

Combustion Air Inlet Pipe

- Sealed, single-wall galvanized pipe is recommended for vent run and terminal combustion air pipe.

Applies to: Residential or Commercial/Industrial Installation

NOTE: Only UDAS 30, 45, 60, 75, 100, and 125 are certified for residential use.

1. Venting and Combustion Air Requirements (cont'd)

1.2 Venter Outlet and Combustion Air Inlet

FIGURE 1 - Rear of Heater showing Location of Inlet and Outlet Connections

Note: Small unit is illustrated. Larger units have slightly different orientation.

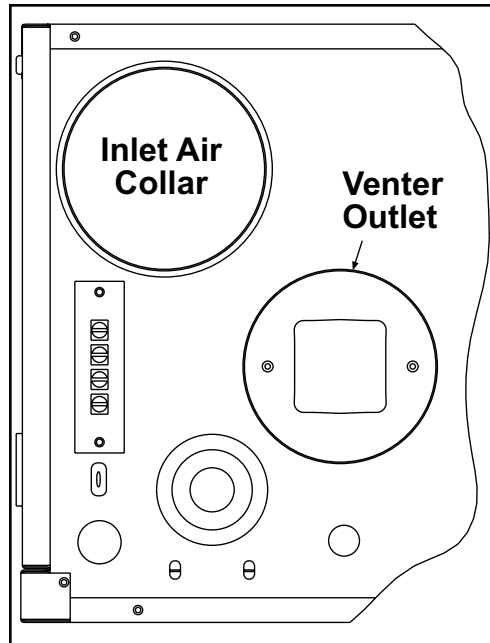
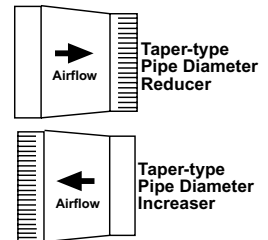

TABLE 1 - Diameter of the Venter Outlet and Combustion Air Inlet Collar

Size	Heater Connections (diameter)			
	Venter Outlet		Inlet Air Collar	
	inches	mm	inches	mm
30	4	102	4	102
45	4	102	4	102
60	4	102	4	102
75	4	102	4	102
100	4	102	4	102
125	4	102	4	102
150	5	127	6	152
175	5	127	6	152
200	5	127	6	152
225	5	127	6	152
250	5	127	6	152
300	6	152	6	152
350	6	152	6	152
400	6	152	6	152

Special Requirements at the Heater Connections

- Sizes 30, 45, and 60 - When using 3" diameter pipe, a 4" to 3" (102 to 76mm) taper-type reducer is required at the venter outlet.
- Sizes 30, 45, and 60 - When using 3" diameter pipe, a 3" to 4" (76 to 102mm) taper-type increaser is required at the inlet air collar.
- Sizes 200, 225, 250, 300, 350, and 400 require a minimum of 12" (305 mm) of straight pipe at both heater connections.



1.3 Pipe Diameter and Length

Diameters of the **outside** (terminal) concentric pipes are listed in **TABLE 2**. Pipe diameter and length requirements listed in **TABLE 3** are for the **indoor** sections of pipe between the heater and the concentric adapter box.

Pipe diameters and maximum indoor vent lengths in **TABLE 3** apply to both **horizontal** and **vertical** vent/combustion air systems. Add **all** straight sections and equivalent lengths for elbows. **The total length of the straight sections and elbows must not exceed the Maximum Length.**

TABLE 2 - Diameters of Outdoor Concentric Pipes (Outlet Side of the Concentric Adapter Box to Terminals)

	Diameters of Concentric (outdoor) Pipes	
UDAS and UDBS	30, 45, 60, 75, 100, 125	150, 175, 200, 225, 250, 300, 350, 400
Inlet Air Pipe Diameter	6" (152mm)	8" (203mm)
Vent Pipe Diameter	4" (102mm)	5" (127mm)

The outdoor pipe lengths depend on the installation; requirements are listed in the installation instructions for the horizontal (Option CC6) and vertical (Option CC2) vent/combustion air kits.

Applies to: Residential or Commercial/Industrial Installation

NOTE: Only UDAS 30, 45, 60, 75, 100, and 125 are certified for residential use.

TABLE 3 - Pipe Diameter and Length from Heater to Concentric Adapter Box

- **Minimum length** between the heater and the concentric adapter box is 1 ft (305mm) for Sizes 30-125 and 3 ft (914mm) for Sizes 150-400.

Pipe Diameter and Maximum Pipe Length from Heater to Concentric Adapter Box										
UDAS and UDBS	Pipe Diameter				Maximum Length		Equivalent Straight Length for a			
	Vent Pipe		Inlet Air Pipe				90° Elbow		45° Elbow	
	inches	mm	inches	mm	feet	M	feet	M	feet	M
30	3	76	3	76	15	4.6	2	0.6	1	0.3
	4	102	4	102	10	3.0	2	0.6	1	0.3
45	3	76	3	76	15	4.6	2	0.6	1	0.3
	4	102	4	102	10	3.0	2	0.6	1	0.3
60	3	76	3	76	25	7.6	3	0.9	1.5	0.5
	4	102	4	102	15	4.6	1.5	0.5	1	0.3
75	4	102	4	102	25	7.6	3	0.9	1.5	0.5
100	4	102	4	102	35	10.7	4	1.2	2	0.6
125	4	102	4	102	35	10.7	4	1.2	2	0.6
150	5	127	6	152	30	9.1	3	0.9	1.5	0.5
175	5	127	6	152	30	9.1	3	0.9	2	0.5
200	5	127	6	152	40	12.2	4	1.2	2	0.6
225	5	127	6	152	40	12.2	4	1.2	2	0.6
250	5	127	6	152	40	12.2	4	1.2	2	0.6
300	6	152	6	152	45	13.7	4	1.2	2	0.6
350	6	152	6	152	45	13.7	5	1.5	2.5	0.8
400	6	152	6	152	45	13.7	5	1.5	2.5	0.8

1.4 Joints and Sealing

NOTE: Joints connecting double-wall pipe apply only to a vertical vent terminal (Option CC2 Vertical Vent/Combustion Air Kit). Horizontal vent does not require double-wall pipe; see Type of Pipe requirement on page 3.

Provide pipes as specified in **Requirement No. 1.1**, page 3, and seal joints as follows:

- **To join sections of Category III pipe**, follow the pipe manufacturer's instructions for joining and sealing.
- **To join sections of single-wall pipe (vent pipe or combustion air pipe)**, secure slip-fit pipe connections using sheetmetal screws or rivets. Seal all joints with aluminum tape or silicone sealant.
- **When joining the terminal section of double-wall vent pipe (vertical vent terminal Option CC2 only) to the vent cap**, follow the illustrated step-by-step instructions in **FIGURE 2**.

When joining the terminal section of double-wall vent pipe (vertical vent terminal Option CC2 only) to the single-wall or Category III vent pipe run, follow the illustrated step-by-step instructions in **FIGURE 3**.

When joining two sections of double-wall vent pipe (vertical vent terminal only; restrictions apply), follow the pipe manufacturer's instructions for joining and sealing vent pipe sections.

Applies to: Residential or Commercial/Industrial Installation

NOTE: Only UDAS 30, 45, 60, 75, 100, and 125 are certified for residential use.

1. Venting and Combustion Air Requirements (cont'd)

1.4 Joints and Sealing (cont'd)

Instructions for Attaching the Terminal-End Double-Wall (Type-B) Section of the VERTICAL Vent Pipe (Applies only to Option CC2 installation)

FIGURE 2 - Follow STEPS to join Double-Wall (Type B) Pipe and the Vent Terminal Cap (applies only to vertical vent/combustion air kit Option CC2)

FIGURE 2 - STEP 1

Place a continual 3/8" bead of silicone sealant around the circumference of the vent cap collar. This will prevent any water inside the vent cap from running down the double-wall pipe.

Do STEP 2 immediately following STEP 1.



FIGURE 2 - STEP 2

Insert the collar on the vent cap inside the inner wall of the double-wall pipe. Insert as far as possible. Add additional silicone sealant to fully close any gaps between the vent cap and the double wall pipe. This is necessary to prevent water from entering the double-wall pipe.

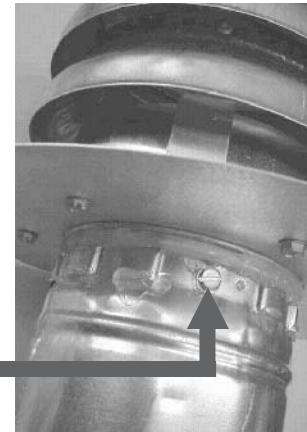

FIGURE 2 - STEP 3

Secure the vent cap to the double-wall pipe by drilling and inserting a 3/4" (19mm) long sheetmetal screw into the vent cap collar. Do not overtighten screw.

FIGURE 3 - Follow STEPS to join Double-Wall (Type B) Pipe (VERTICAL VENT Option CC2 ONLY) to Single-Wall Pipe, to Category III Pipe, or to a Taper-type Connector

FIGURE 3 - STEP 1

On the single-wall pipe, Category III pipe, or taper-type connector, place a continual 1/4" bead of silicone sealant around the circumference.

Do STEP 2 immediately following STEP 1.

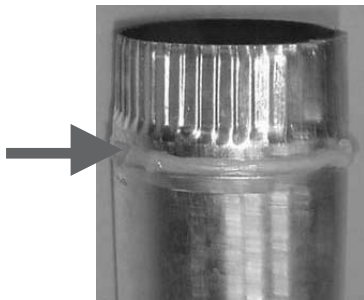
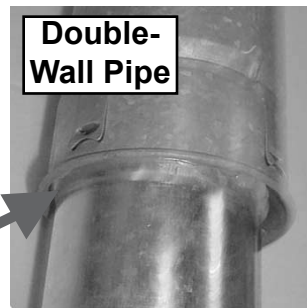

FIGURE 3 - STEP 2

Insert the pipe prepared with sealant into the inner pipe of the double-wall pipe until the bead of sealant contacts the inner pipe creating a sealed joint.



Single-Wall Pipe with Sealant (STEP 1)

FIGURE 3 - STEP 3

Spaced equally around the double-wall pipe, drill three small holes below the sealant ring. Insert 3/4 inch (19mm) long sheetmetal screws to secure the joint. Do not overtighten screws.

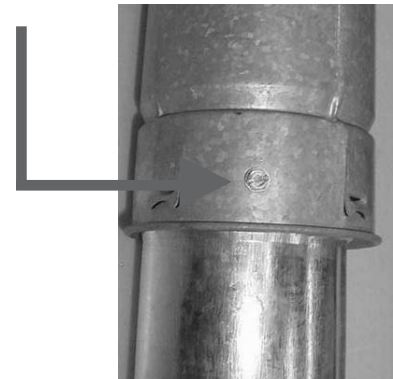

1.5 Support

Support horizontal run every six feet (1.8M). Support vertical run of Category III vent pipe in accordance with the requirements of the pipe manufacturer. Support vertical single-wall pipe in accordance with accepted industry practices. Do not rely on the heater or the adapter box for support of either horizontal or vertical pipes. Use non-combustible supports on vent pipe.

NOTE: The vertical vent double-wall vent terminal pipe does not attach to the concentric adapter box and must be supported during installation.

Applies to: Residential or Commercial/Industrial Installation

NOTE: Only UDAS 30, 45, 60, 75, 100, and 125 are certified for residential use.

1.6 Condensation

CAUTION:
Exceeding the specified vent pipe diameter and length may result in condensate forming in the vent pipe.

On units with long vent runs (over 50% of maximum vent length allowed) or installed in low ambient conditions (below 50°F), it is recommended that vent pipes be fitted with a tee, a drip leg, and a clean out cap to prevent any moisture in the vent pipe from entering the unit. The drip leg should be inspected and cleaned out periodically during the heating season.

On all Model Sizes, any length of single-wall vent pipe exposed to cold air, or run through an unheated area, or an area with an ambient temperature of 50°F or less, **must be insulated along its entire length** with a minimum of 1/2" foil-faced fiberglass, 1-1/2# density insulation.

On horizontal vent runs, the flue pipe **must be pitched down toward the outlet** 1/4" per foot for condensate drainage. Slope applies to entire length of horizontal vent run. Failure to pitch vent run properly may damage unit due to condensate running back into the unit.

1.7 Clearance

Do not enclose the vent pipe or place pipe closer than 6" (152mm) to combustible material.

1.8 Concentric Adapter Box

All separated combustion installations **require** a concentric adapter box as illustrated in **FIGURE 4**. The concentric adapter box is included in the vent/combustion air terminal kit. Installation instructions depend on whether the vent terminal is horizontal (Option CC6) or vertical (Option CC2).

FIGURE 4 - A Concentric Adapter Box is a Required Part of all Model UDAS and UDBS Installations

A vent/combustion air kit which includes the concentric adapter box is ordered with the heater. A horizontal terminal vent/combustion air kit is Option CC6; a vertical terminal vent/combustion air kit is Option CC2.

NOTE: A Size 30, 45, 60, or 75 with a horizontal vent may use Option CC14, a more aesthetic concentric vent terminal/combustion air kit that terminates flush with the wall. If installing Option CC14, follow the instructions in the option package (Form I-UDAS/UDBS-ASC).

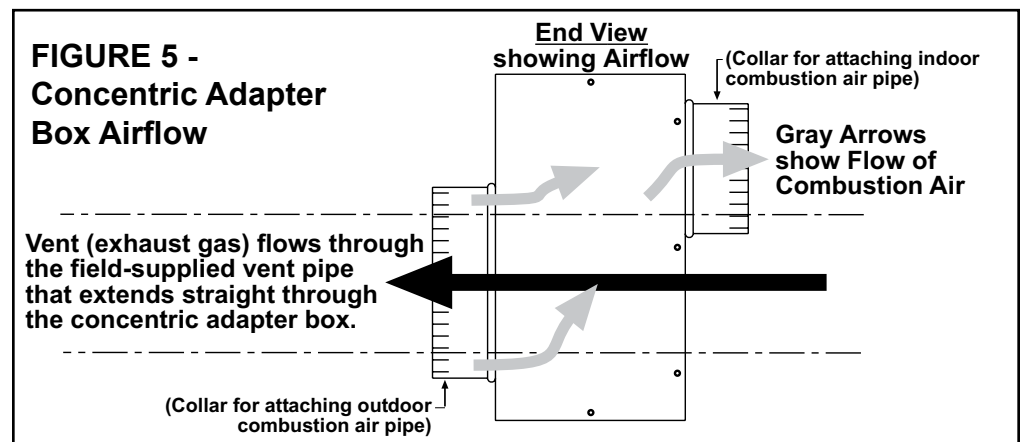
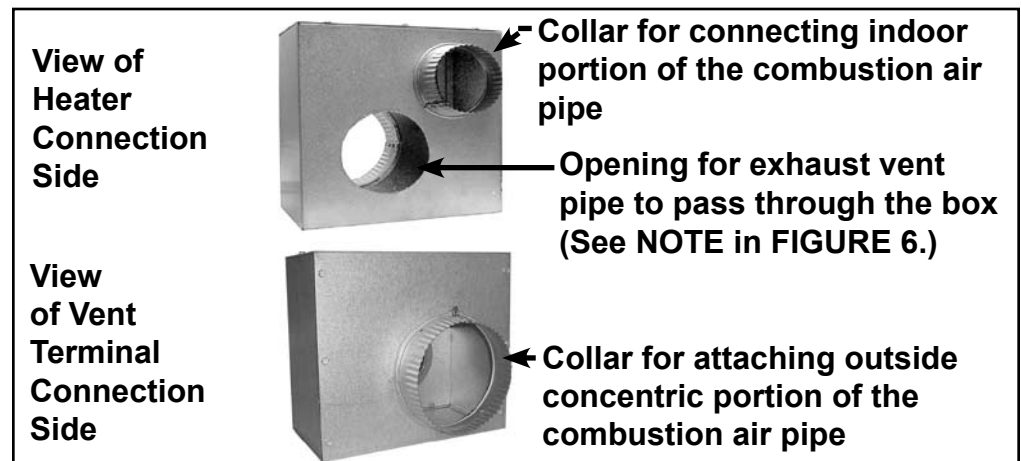

The illustrations in **FIGURE 4** and **FIGURE 5** apply to the concentric adapter box in both the horizontal terminal vent/combustion air kit (Option CC6) and the vertical terminal vent/combustion air kit (Option CC2). All dimensions are the same except for the opening for the vent pipe (See **NOTE** in **FIGURE 6**).

Applies to: Residential or Commercial/Industrial Installation

NOTE: Only UDAS 30, 45, 60, 75, 100, and 125 are certified for residential use.

1. Venting and Combustion Air Requirements (cont'd)

1.8 Concentric Adapter Box (cont'd)

**FIGURE 6 -
Concentric Adapter
Box Dimensions**

NOTE: Horizontal and vertical kits do not use the same adapter box. The only difference is the diameter of the opening in the box for the vent pipe. A vertical vent requires double-wall pipe and a slightly larger opening through the box. See TABLE below and P/N list on page 10 or page 14.

Diameter of Opening for Vent Pipe				
Vent Terminal Configuration	Sizes 30-125		Sizes 150-400	
	inches	mm	inches	mm
Horizontal (Option CC6)	4-1/16	103	5-1/16	129
Vertical (Option CC2)	4-21/32	118	5-21/32	144

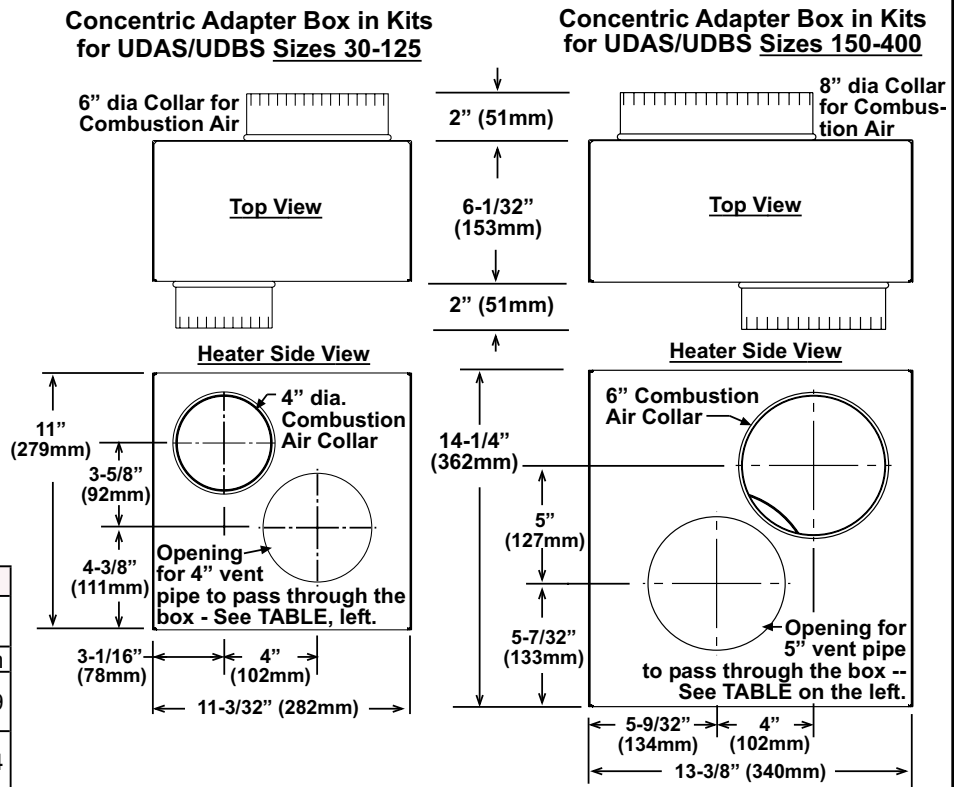

Pipe Connections at the Concentric Adapter Box

When pipe diameters differ, depending on direction of airflow, join the pipes with either a taper-type reducer or increaser. Requirements vary depending on the size of the heater; refer to **FIGURE 7, 8, or 9** to determine whether or not pipe diameters differ. Do **NOT** make actual connections until after reading the instructions and length requirements for installing the vent/combustion air kit. **The connection requirements are the same for both vertical and horizontal systems, but the length of pipe required varies by installation.**

- If using 3" (76mm) diameter pipes, Sizes 30, 45, and 60 require a 3" to 4" (76 to 102mm) increaser in the vent pipe.

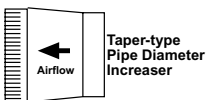

- If using 3" (76mm) diameter pipes, Sizes 30, 45, and 60 require a 4" to 3" (102 to 76mm) reducer on the combustion air pipe collar.

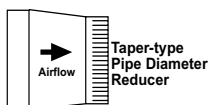
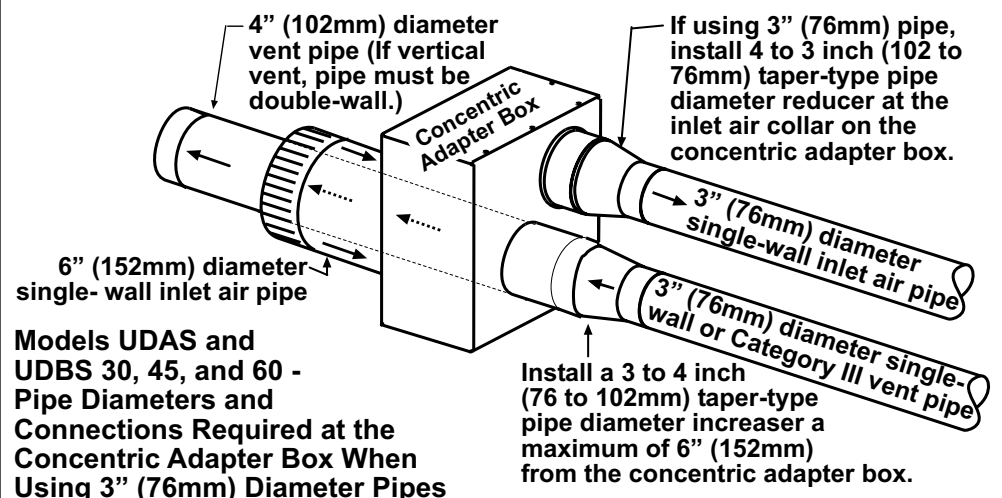

FIGURE 7 - Concentric Adapter Box Connections for Sizes 30, 45, and 60 using 3" (76mm) diameter pipes



Applies to: Residential or Commercial/Industrial Installation

NOTE: Only UDAS 30, 45, 60, 75, 100, and 125 are certified for residential use.

FIGURE 8 - Concentric Adapter Box Connections for Sizes 30, 45, and 60 using 4" (102mm) diameter pipes and for all Installations of Sizes 75, 100, 125, 150, 175, 200, 225, and 250

Models UDAS and UDBS 30, 45, and 60 - Pipe Diameters and Connections Required at the Concentric Adapter Box When Using 4" (102mm) Diameter Pipes from the Heater to the Concentric Adapter

AND

Models UDAS and UDBS 75, 100, 125, 150, 175, 200, 225, and 250 - Pipe Diameters and Connections Required at the Concentric Adapter Box

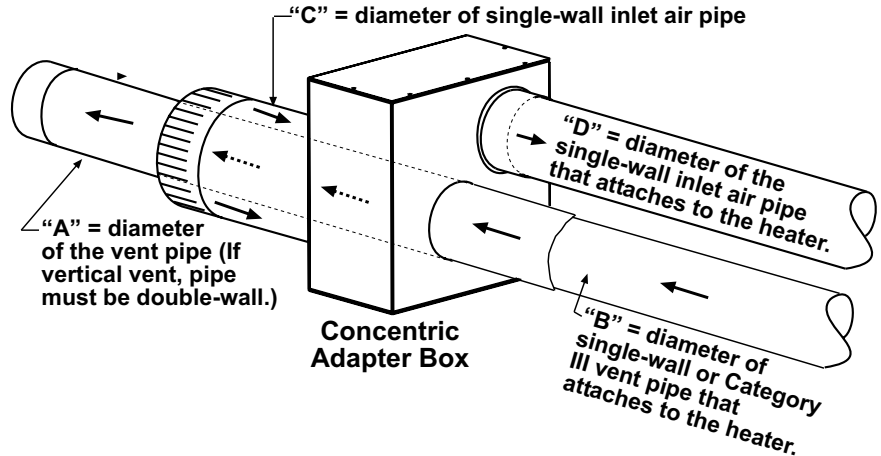

- Pipe diameters do not differ. Taper-type connectors are not required for these installations.

Model UDAS and UDBS Sizes		A	B	C	D
30, 45, 60 with 4" vent and combustion air runs from heater to concentric adapter box	inches	4	4	6	4
	mm	102	102	152	102
75, 100, 125	inches	4	4	6	4
	mm	102	102	152	102
150, 175, 200, 225, 250	inches	5	5	8	6
	mm	127	127	203	152

FIGURE 9 - Concentric Adapter Box Connections for Sizes 300, 350, and 400

Models UDAS and UDBS 300, 350, and 400 - Pipe Diameters and Connections Required at the Concentric Adapter Box

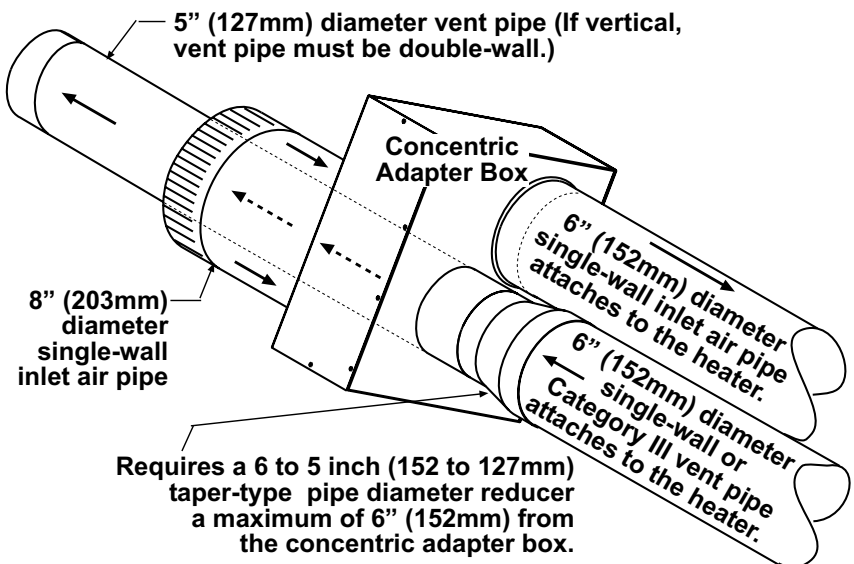

- Sizes 300, 350, and 400 **always** require a 6" to 5" (152 to 127 mm) reducer in the vent pipe.

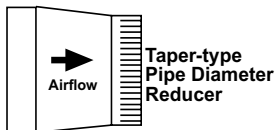

Applies to: Residential or Commercial/Industrial Installation

NOTE: Only UDAS 30, 45, 60, 75, 100, and 125 are certified for residential use.

HORIZONTAL OR VERTICAL VENT TERMINAL?

FIGURE 10 - Is the Separated-Combustion Vent/Combustion Air System Horizontal or Vertical?

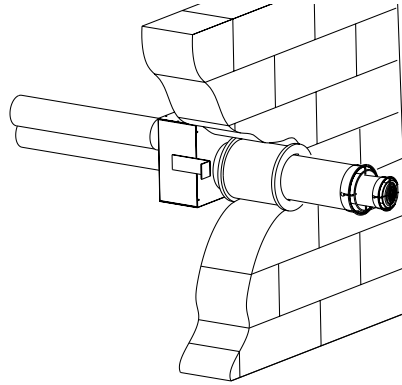

Horizontal, Option CC6, instructions begin below.

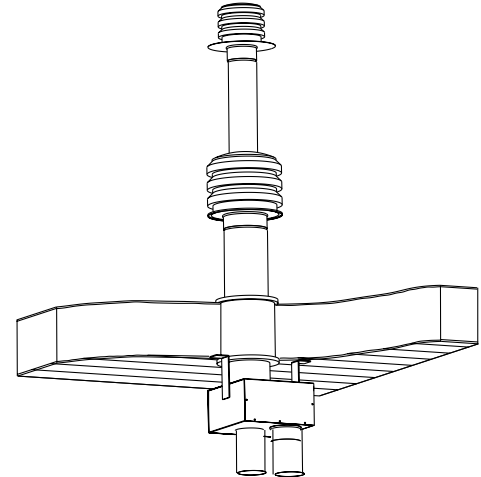



Vertical, Option CC2, instructions begin on page 14.

2. HORIZONTAL VENT INSTRUCTIONS - Option CC6

TABLE 4 - Parts in the Horizontal Vent/Combustion Air Terminal Package (Option CC6)

2.1 Components Required - Factory and Field

Qty	Sizes	P/N	Description
1	30-125	211762	Complete Horizontal Vent/Combustion Air Terminal Kit (Same as Option CC6)
	150-400	211763	
1	30-125	211789	Concentric Adapter Box (NOTE: Refer to FIGURE 6 , page 8, and verify diameter of vent pipe opening.)
	150-400	211790	
1	30-125	211791	Exhaust Grill 
	150-400	211792	
1	30-125	151755	Inlet Guard 
	150-400	124940	
8	30-400	37661	#10-16 x 1/2" long Screws to attach the exhaust grill and the inlet guard
2	30-400	207232	Brackets for attaching Concentric Adapter Box (See FIGURE 11 , page 12.)
1	30-400	53335	Tube of High Temperature (450°F) Silicone Sealant

Field-supplied requirements:

- Vent pipes - see type requirements, page 3
- Combustion air pipes - see type requirements, page 3
- Taper-type vent pipe diameter reducers and/or increasers as required
- Thimble (a thimble is not required if wall is of non-combustible construction)
- Flashing
- Sheetmetal screws, tape, and sealant as required

Applies to: Residential or Commercial/Industrial Installation

NOTE: Only UDAS 30, 45, 60, 75, 100, and 125 are certified for residential use.

2.2 Installation Instructions for Horizontal Vent/ Combustion Air Kit Option CC6 (in compliance with requirements on pages 3-10)

Before beginning, verify that the kit is at the site and that all components are correct for the installation. Be sure all required field-supplied parts are available.

1) Determine the location on the outside wall for the vent terminal. Location must comply with vent length requirements, Requirement No. 1.3 on page 4. In most applications, the terminal would be on a level with the heater mounting height. Allow 1/4" per foot (6mm per 305mm) downward pitch for condensate drain.

Minimum clearances for the horizontal vent terminal are shown in **TABLE 5**. Also, select a location that complies with adjoining building clearances as shown in **FIGURE 12**, page 13.

Products of combustion can cause discoloring of some building finishes and deterioration of masonry materials. Applying a clear silicone sealant that is normally used to protect concrete driveways can protect masonry materials. If discoloration is an esthetic problem, re-locate the vent or install a vertical vent.

WARNING: All vent terminals must be positioned or located away from fresh air intakes, doors and windows to preclude combustion products from entering occupied space. Failure to comply could result in severe personal injury or death and/or property damage.

TABLE 5 - Clearances to Horizontal Vent Terminal

Structure	Minimum Clearances for Vent Terminal Location (all directions unless specified)
Forced air inlet within 10 ft (3.1M)*	3 ft (0.9M) above
Combustion air inlet of another appliance	6 ft (1.8M)
Door, window, or gravity air inlet (any building opening)	4 ft (1.2M) horizontally
	4 ft (1.2M) below
	1 ft (305mm) above
Electric meter, gas meter ** and relief equipment	U.S. - 4 ft (1.2M) horizontally
	Canada - 6 ft (1.8M)
Gas regulator **	3 ft (0.9M) horizontally
Adjoining building or parapet	6 ft (1.8M)
Adjacent public walkways	7 ft (2.1M) above
Grade (ground level)	3 ft (0.9M) above***
*Does not apply to the inlet of a direct vent appliance. **Do not terminate the vent directly above a gas meter or service regulator. *** Consider local snow depth conditions. The vent must be at least 6" (152mm) higher than anticipated snow depth.	

2) Install the Vent Pipe and Combustion Air Pipe Runs - Use the type of pipe specified in Requirement No. 1.1, page 3. Comply with requirements in Requirement No. 1.2, page 4, when attaching pipes to the heater. Length must comply with Requirement 1.3, pages 4-5.

Seal all joints. Due to the high temperature, **do not** enclose the exhaust pipe or place pipe closer than 6" (152 mm) to combustible material. Extend the runs close to the wall location selected in Step 1. Support pipes as required in Requirement No. 1.5, page 6. Comply with requirements concerning condensation in Paragraph 1.6.

Applies to: Residential or Commercial/Industrial Installation

NOTE: Only UDAS 30, 45, 60, 75, 100, and 125 are certified for residential use.

2. HORIZONTAL VENT INSTRUCTIONS - Option CC6 (cont'd)

2.2 Installation Instructions for Horizontal Vent/Combustion Air Kit Option CC6 (cont'd)

3) Prepare a clearance hole through the outside wall for the combustion air pipe -- a 6" (152mm) diameter pipe for Sizes 30-125 or an 8" (203mm) diameter pipe for Sizes 150-400. Outside wall construction thickness should be 1" (25mm) minimum and 48" (1219 maximum). The larger diameter combustion air pipe serves as clearance for the vent pipe on non-combustible construction. A thimble may be required depending on wall construction and/or local codes.

4) Prepare the Concentric Adapter Box

a. Attach the brackets to the box. Follow the instructions in **FIGURE 11**.

FIGURE 11 - Brackets for Attaching the Concentric Adapter Box to the Wall

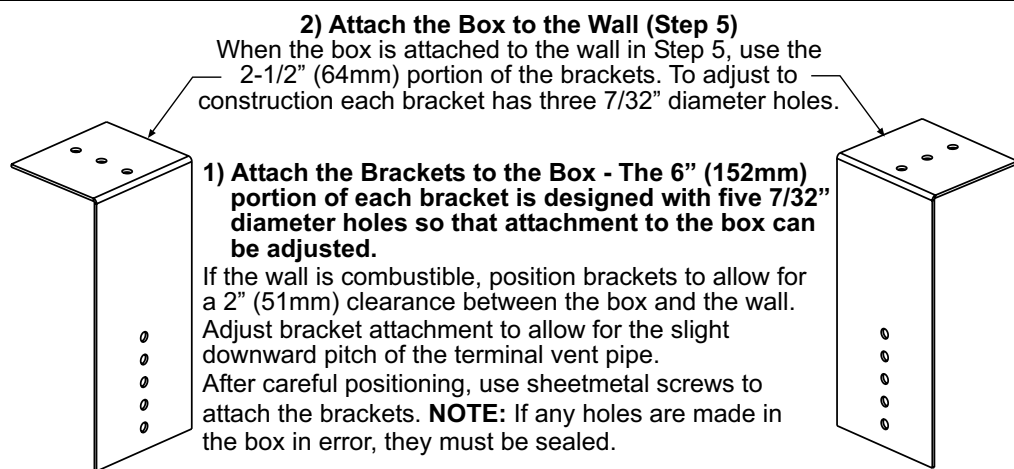

b. Attach the outside portion of the combustion air pipe to the box. Determine the length by measuring the bracket length from box to wall, plus the wall thickness, plus 4-16" (102-406 mm) beyond the wall. (The inlet air pipe should extend beyond the outside wall a minimum of 4" (102mm) to a maximum or 16" (406mm).

Attach the inlet air pipe to the collar of the concentric adapter with sheetmetal screws and seal.

5) Attach the concentric adapter box to the wall. Insert the combustion air pipe out through the wall. Attach the brackets to the wall (**FIGURE 11**). On the outside, caulk or flash the inlet air pipe. Flashing is field-supplied.

6) On the outside, position the inlet air guard over the end of the combustion air pipe. See **FIGURE 12**, below and next page. Attach the guard to the inlet air pipe with the four 1/2" long screws provided.

7) Determine length and install the "terminal-end" vent pipe.

a. Determine length of pipe. The length of the continuous piece of terminal-end vent pipe is determined by the installation within the maximum and minimum requirements. See **FIGURE 12** to determine lengths of each segment and calculate the total length required. The "terminal-end" vent pipe extending through the box and concentric through the inlet air pipe **must be one piece of vent pipe without joints**. The connection to the vent pipe run, must be a maximum of 6" (152mm) from the heater side of the box.

b. Install terminal-end vent pipe. Being sure the vent pipe is in the proper flow direction, slide the end through the box.

Applies to: Residential or Commercial/Industrial Installation

NOTE: Only UDAS 30, 45, 60, 75, 100, and 125 are certified for residential use.

Position the vent pipe so that it will extend between 3" (76mm) and 6" (152mm) past the end of the combustion air pipe and no more than 6" (152mm) out of the box toward the heater.

No more than 6" (152mm) from the box, connect the terminal-end vent pipe to the vent pipe run from the heater.

FIGURE 12 - Installation of a Typical Separated-Combustion Unit with Horizontal Vent Terminal and Combustion Air Pipe (Option CC6)

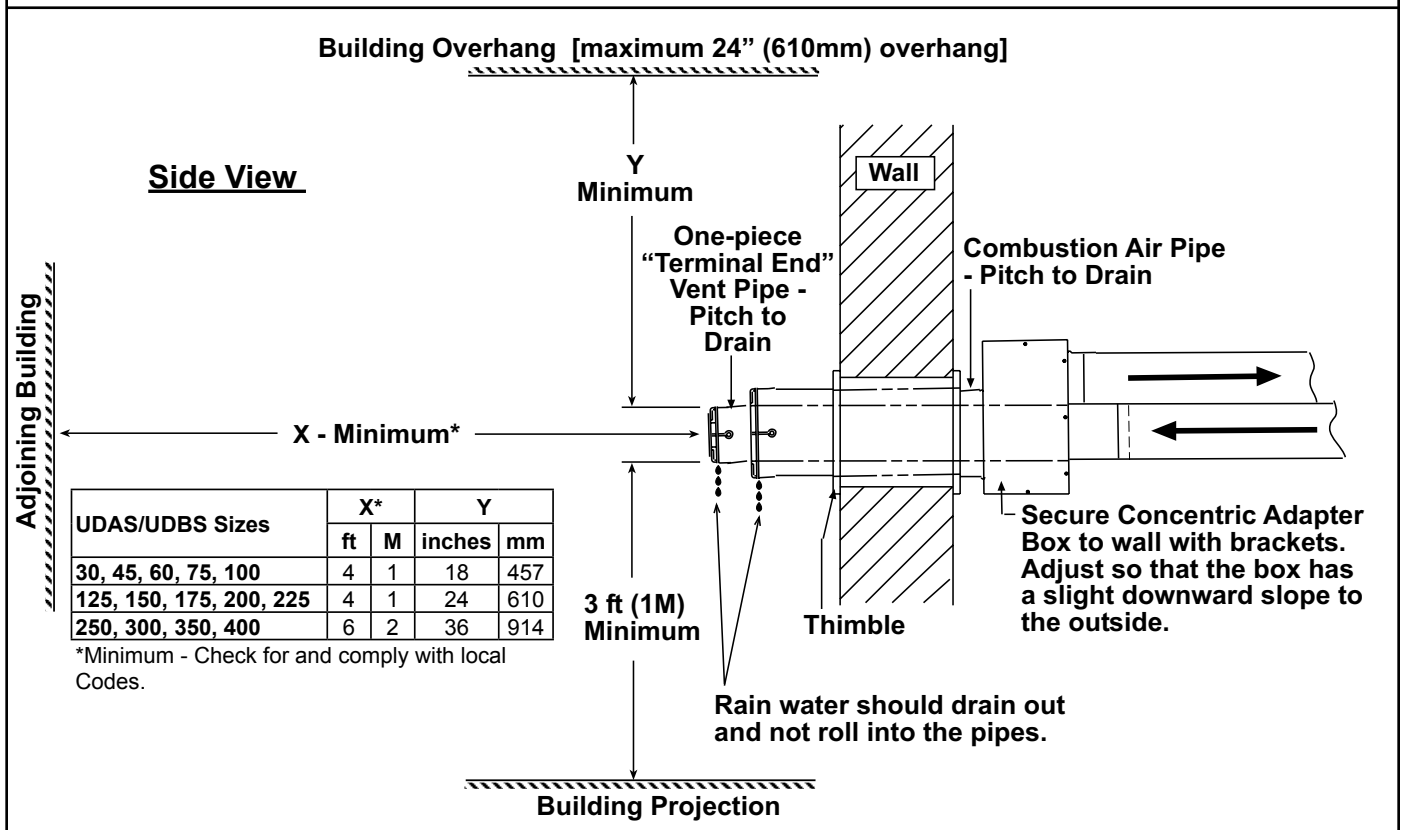
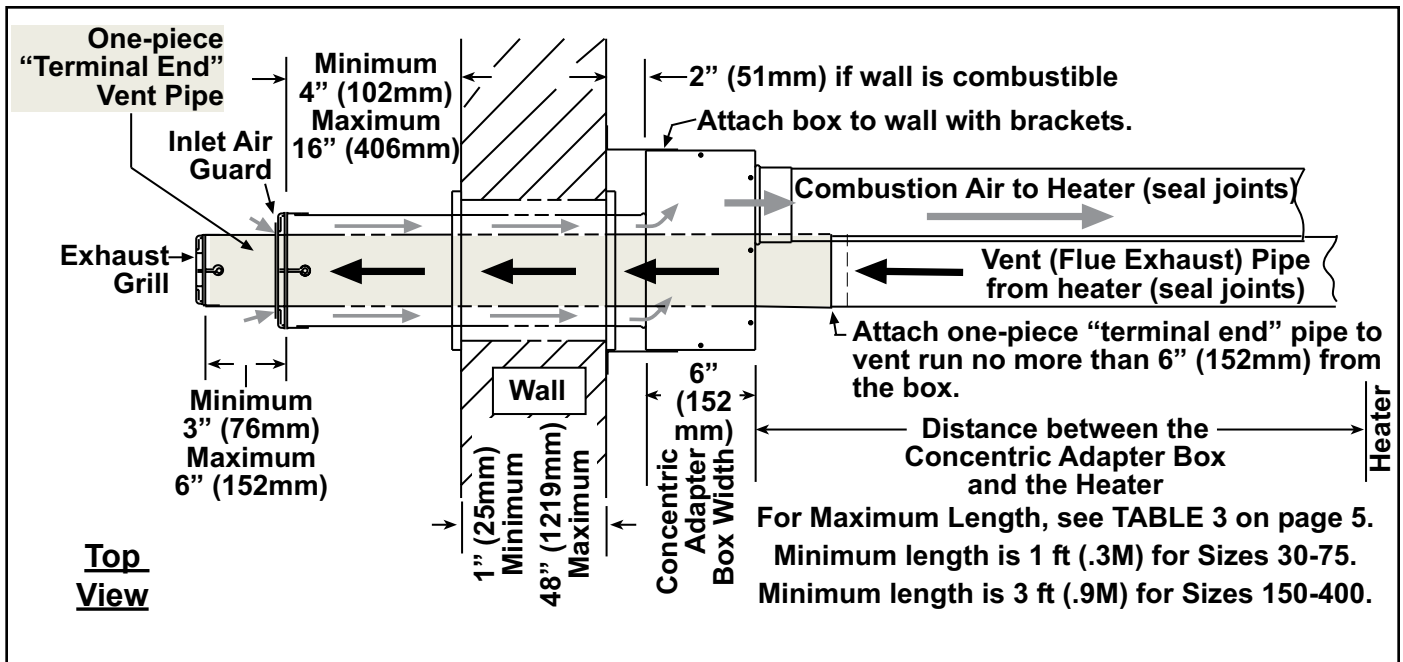

Applies to: Residential or Commercial/Industrial Installation

NOTE: Only UDAS 30, 45, 60, 75, 100, and 125 are certified for residential use.

2. HORIZONTAL VENT INSTRUCTIONS - Option CC6 (cont'd)

2.2 Installation Instructions for Horizontal Vent/Combustion Air Kit Option CC6 (cont'd)

8) Position the exhaust grill over the end of the vent pipe. See **FIGURE 12, Top View**. Attach the grill to the end of the vent pipe with the four 1/2" long screws in the kit.

9) Seal the vent pipe to the concentric adapter box. Verify that the terminal-end section of vent pipe has a slight downward drop (1/4" per foot/6mm per 305mm) toward the outside. Use silicone sealant and seal the circumference of the pipe and the opening of the box. Seal the area around the pipe completely.



10) Attach the indoor combustion air pipe. Use sheetmetal screws to attach the single-wall combustion air pipe run to the collar on the concentric adapter box. Seal with tape or sealant. If using 3" combustion air pipe on Size 30, 45, or 60, install a taper-type reducer as illustrated in **FIGURE 7**, page 8. Review Paragraph 1.6 concerning condensation; comply with all requirements that apply.

Installation of the horizontal vent and combustion air system on your separated-combustion unit is complete. **Verify compliance with all venting installation requirements, pages 3-9, and FIGURE 12, page 13.**

3. VERTICAL VENT INSTRUCTIONS - Option CC2

3.1 Components Required - Factory and Field

TABLE 6 - Parts in the Vertical Vent Terminal/Combustion Air Package (Option CC2)

Qty	Size	P/N	Description
1	30-125	205895	Complete Vertical Vent Kit (Same as Option CC2)
	150-400	205896	
1	30-125	205884	Concentric Adapter Box (NOTE: Refer to FIGURE 6 , page 8, and verify diameter of vent pipe opening.)
	150-400	205885	
1	30-125	155631	Exhaust (Vent) Terminal Assembly 
	150-400	53326	
1	30-125	155635	Combustion Air Inlet Assembly 
	150-400	53330	
2	30-400	207232	Brackets for attaching Concentric Adapter Box (See FIGURE 13 , page 16.)
1	30-400	53335	Tube of High Temperature Silicone Sealant

Field-supplied requirements:

- Vent pipes - see type requirements, page 3
- Combustion air pipes - see type requirements, page 3
- Taper-type pipe diameter reducers and/or increasers as required
- Thimble (a thimble is not required if wall is of non-combustible construction)
- Flashing
- Sheetmetal screws, tape, and sealant as required

Before beginning, verify that the kit is at the site and that all components are correct for the installation. Be sure all required field-supplied parts are available.

Applies to: Residential or Commercial/Industrial Installation

NOTE: Only UDAS 30, 45, 60, 75, 100, and 125 are certified for residential use.

3.2 Installation Instructions for Vertical Vent/Combustion Air Kit Option CC2 (in compliance with requirements on pages 3-10)

1) Determine the location of the vent terminal.

Select a location away from fresh air intakes, allowing space for the concentric adapter box inside. Vent terminal must be located from adjacent buildings as shown in **FIGURE 17**, page 18.

WARNING: All vent terminals must be positioned or located away from fresh air intakes, doors and windows to preclude combustion products from entering occupied space. Failure to comply could result in severe personal injury or death and/or property damage.

If more than one vertical concentric vent/combustion air terminal (Option CC2) is being installed, the minimum spacing between vent centerlines is determined by the minimum outdoor design temperature (most extreme outdoor condition at the installation site).

Minimum Outdoor Design Temperature		Minimum Spacing between Centerlines of Vent Pipes in Vertical Combustion Air/Vent Terminals (Option CC2)	
°F	°C	inches	mm
31 or warmer	0 or warmer	36	914
-10 to 30	-23 to -1	60	1524
less than -10	less than -23	84	2134

2) Install the Vent Pipe and Combustion Air Pipe Run - Use the type of pipe specified (Requirement No. 1), page 3, and comply with the attachment requirements in Requirement No. 1.2, page 4. Length must comply with Requirement No. 1.3, pages 4-5.

Seal all joints. Due to the high temperature, **do not** enclose the exhaust pipe or place pipe closer than 6" (152 mm) to combustible material. Provide supports for the pipes. Extend the runs to close to the roof at the location selected in Step 1.

3) Prepare a clearance hole through the roof for the combustion air pipe -- a 6" (152mm) diameter pipe for Sizes 30-125 or an 8" (203mm) diameter pipe for Sizes 150-400. A thimble may or may not be required depending on building construction and/or local codes. The larger diameter combustion air pipe serves as clearance for the vent pipe on non-combustible construction.

4) Prepare the Concentric Adapter Box

a. Attach the brackets to the box. Follow the instructions in **FIGURE 13**.

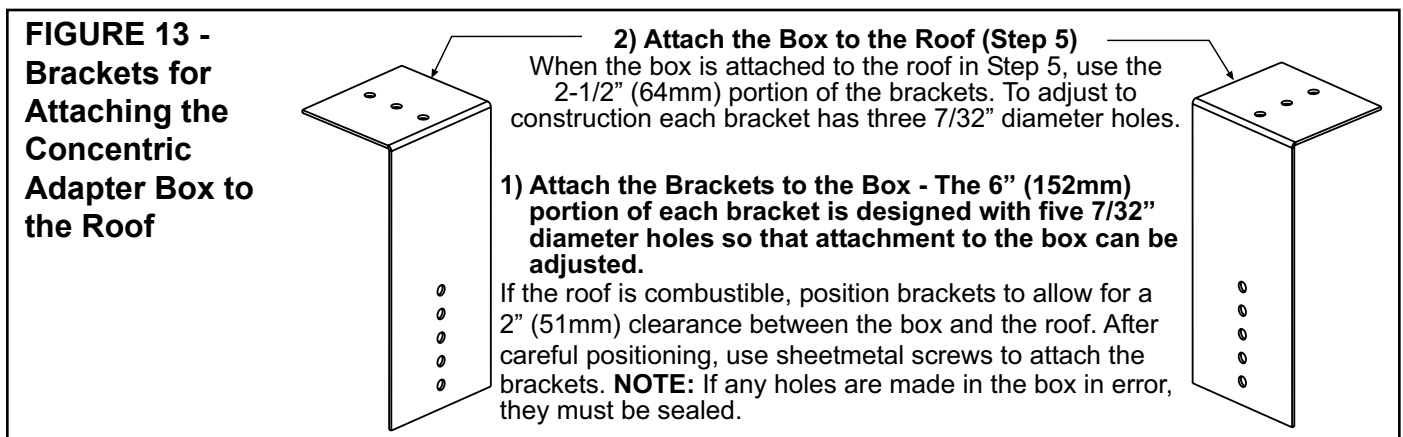

Applies to: Residential or Commercial/Industrial Installation

NOTE: Only UDAS 30, 45, 60, 75, 100, and 125 are certified for residential use.

3. VERTICAL VENT INSTRUCTIONS - Option CC2 (cont'd)

3.2 Installation Instructions for Vertical Vent/Combustion Air Kit Option CC2 (cont'd)

b. Attach the outside portion of the combustion air pipe to the box. Determine the length of the combustion air pipe so that dimension "X" in **FIGURE 14** is equal to the bracket length, plus the roof thickness, plus anticipated snow depth, but does not exceed 48" (1219mm) or have less than 18" (457mm) of pipe above the roof. Attach the inlet air pipe to the collar of the concentric adapter box with sheetmetal screws.

5) Attach the concentric adapter box to the roof. On the inside, insert the combustion air pipe up through the opening and attach brackets to the roof. (See **FIGURES 13, 14, and 15.**) On the outside, flash the combustion air pipe to the roof. Flashing is field supplied.

6) Determine the length and install the double-wall vent pipe.

a. Determine minimum length of the continuous section of double-wall vent pipe. See **FIGURE 14**. The vent pipe extending through the box and the inlet air pipe **must be one piece of double-wall vent pipe without joints**.

Determine the minimum length by adding the requirements. Starting at the bottom, the maximum the vent pipe can extend below the box is 6" (152mm); **plus** 6" (152mm) through the box; **plus** length of bracket extending above the

FIGURE 14 - Concentric Adapter Box, Outdoor Combustion Air Pipe, and Concentric Vent Pipe

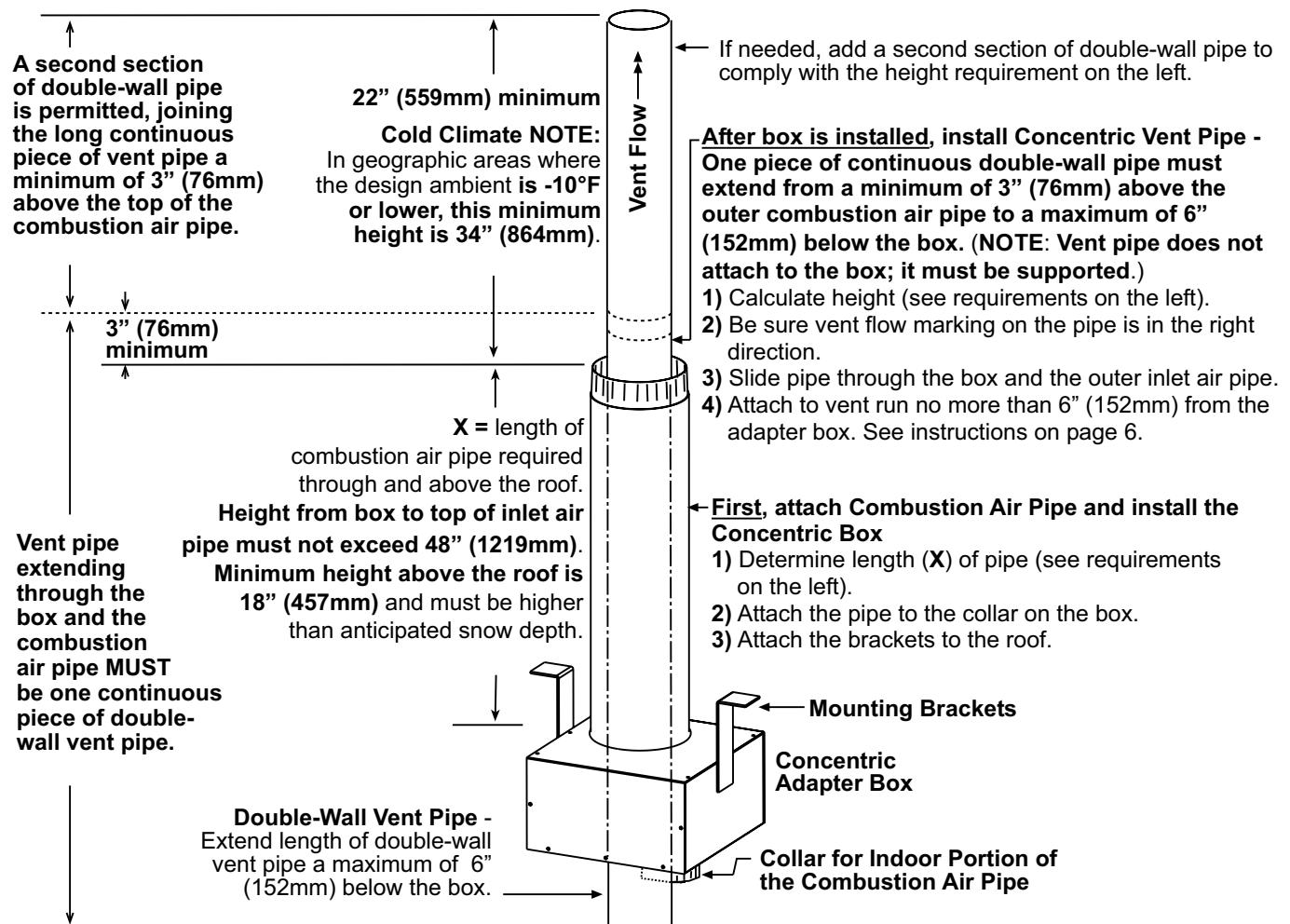

Applies to: Residential or Commercial/Industrial Installation

NOTE: Only UDAS 30, 45, 60, 75, 100, and 125 are certified for residential use.

box; **plus** the width of the roof; **plus** the height of the outside combustion air pipe above the roof; **plus** a minimum of 3" (76mm) beyond the top of the inlet air pipe. Total is the minimum length of the vent pipe section. If the actual piece of vent pipe is longer, extend it further above the combustion air pipe. Do not extend it more than 6" (152mm) below the box.

b. Install the pipe. Being sure the pipe is in the proper flow direction, slide the end into the box and out through the combustion air pipe. Position the vent pipe so that the end is no more than 6" (152mm) below the box. The upper end should extend at least 3" (76mm) above the combustion air pipe. **NOTE: The double-wall vent pipe does not attach to the box. The installer must provide support.**

Follow the instructions in **FIGURE 3**, page 6, for connecting the double-wall pipe to the single-wall pipe, Category III pipe, or taper-type connector.

Seal the circumference of the pipe and the opening of the box with silicone sealant. Seal the area around the pipe completely.

**FIGURE 15 -
Slide attached
Combustion
Air Pipe up
through the
Roof**

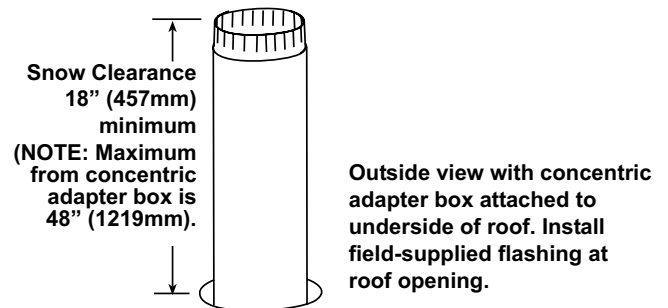

7) On the outside, if an additional section of double-wall pipe is needed (See **FIGURE 16**), add it. Make joint according to the pipe manufacturer's requirements. When vent pipe is the required height, **slide the combustion air inlet** over the vent pipe and fasten the collar to the combustion air pipe with sheetmetal screws. See **FIGURE 16**. Seal the opening at the top between the vent pipe and the combustion air inlet with silicone sealant to prevent water leakage.

**FIGURE 16 - Install
Combustion Air Inlet
and Vent Terminal**

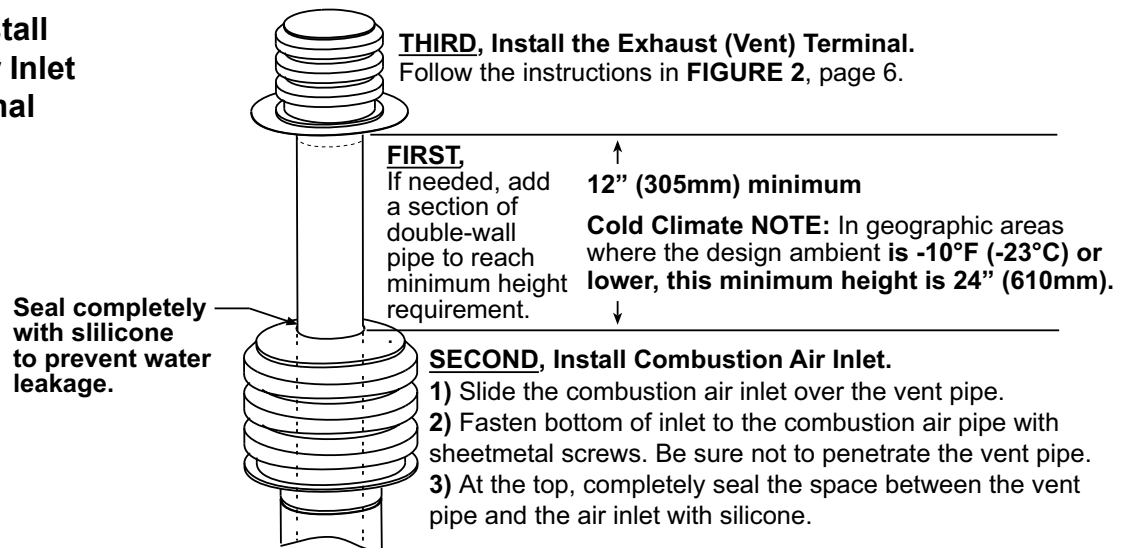

Applies to: Residential or Commercial/Industrial Installation

NOTE: Only UDAS 30, 45, 60, 75, 100, and 125 are certified for residential use.

3. VERTICAL VENT INSTRUCTIONS - Option CC2 (cont'd)

3.2 Installation Instructions for Vertical Vent/ Combustion Air Kit Option CC2 (cont'd)

8) Attach the exhaust (vent) cap. Follow the illustrated instructions in FIGURE 2, page 6.

9) Attach the indoor combustion air pipe. Use sheetmetal screws to attach the single-wall combustion air pipe run to the collar on the concentric adapter box. Seal with tape or sealant. If using 3" combustion air pipe on Sizes 30, 45, and 60, install a taper-type reducer as illustrated in FIGURE 7, page 8. Review Paragraph 1.6 concerning condensation; comply with all requirements that apply.

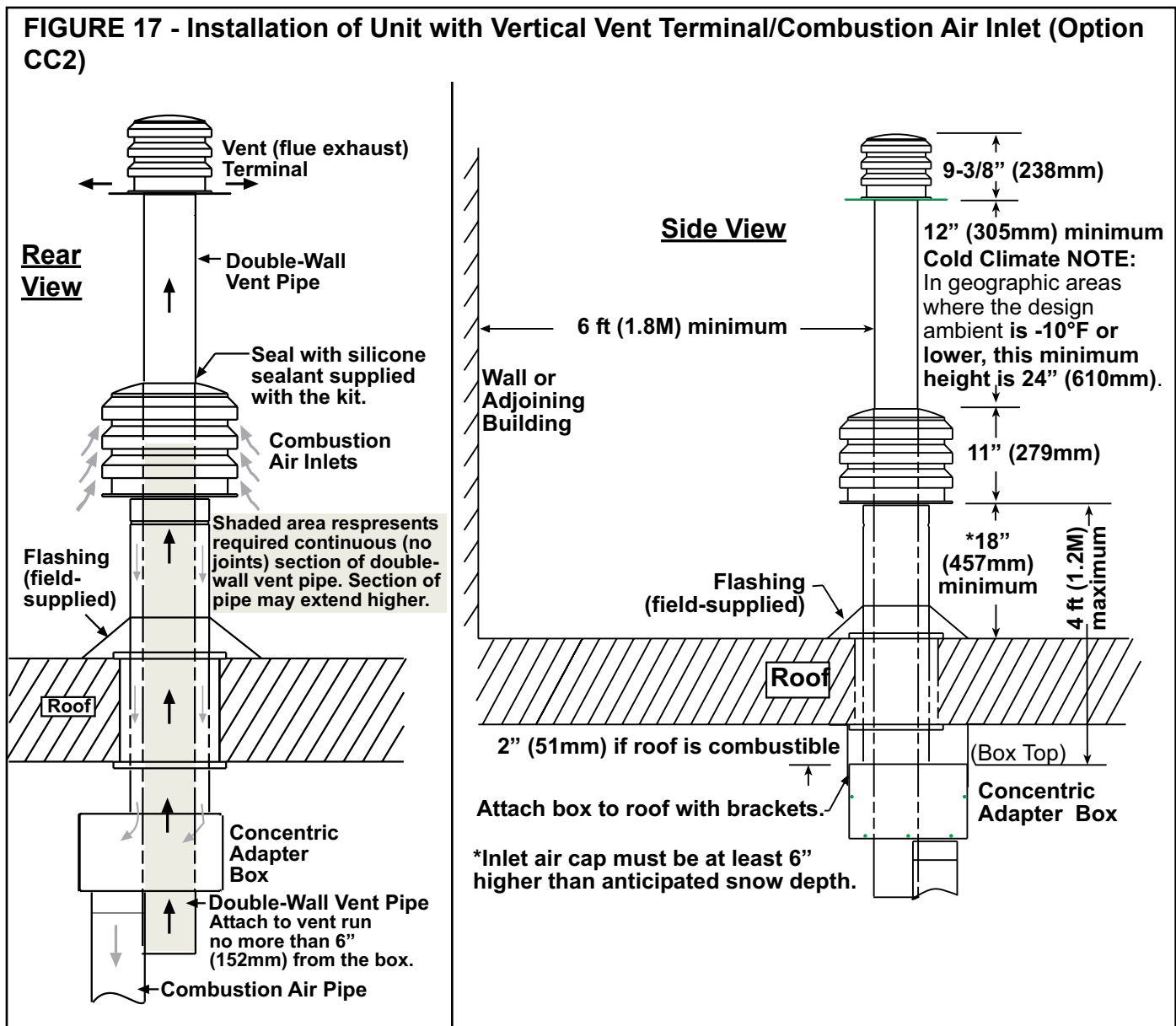

Installation of the vertical vent and combustion air system on your separated-combustion unit is complete. **Verify compliance with all venting installation requirements, pages 3-9, and FIGURE 17.**

INDEX

B

- Brackets for Attaching the Concentric Adapter Box to the Roof 15
- Brackets for Attaching the Concentric Adapter Box to the Wall 12

C

- Hazards of Chlorine 2
- Clearance 7
- Clearances to Horizontal Vent Terminal 11
- Combustion Air Inlet 17
- Combustion Air Inlet Collar 4
- Components 10, 14
- Condensation 7
- Pipe Connections at the Concentric Adapter Box 8

D

- Diameters of Concentric (outdoor) Pipes 4
- Concentric Adapter Box Dimensions 7, 8

H

- Heater Connections 4
- HORIZONTAL VENT INSTRUCTIONS - Option CC6 10

I

- increaser 8
- inlet air guard 12
- Installation Instructions for Horizontal Vent Kit 11
- Installation Instructions for Vertical Vent Kit 15
- Instructions for Attaching the Terminal-End Double-Wall (Type-B) Section of the VERTICAL Vent Pipe 6

J

- Joints 5, 6

L

- Length from Heater to Concentric Adapter Box 5

O

- Outdoor Concentric Pipes 4

P

- Parts in the Horizontal Vent/Combustion Air Terminal Package (Option CC6) 10
- Parts in the Vertical Vent Terminal/Combustion Air Package (Option CC2) 14
- Pipe Diameter 4
- Pipe Diameter and Maximum Pipe Length from Heater to Concentric Adapter Box 5
- Commercial/Industrial Installation - Pipe Requirements 3
- Residential Installation - Pipe Requirements 3

R

- reducer 8, 9

S

- Support 6

T

- terminal-end vent pipe 12
- Type of Pipe 3, 4
- Typical Separated-Combustion Unit with Horizontal 13

V

- Venting and Combustion Air Requirements 2
- VENT TERMINAL 10
- Vent Terminal 17
- VERTICAL VENT INSTRUCTIONS - Option CC2 14

www.RezSpec.com
(800) 695-1901

©2010 Thomas & Betts, All rights reserved.

Trademark Note: Reznor®, T^{CORE}2®, and V³® are registered in at least the United States.

04/10 Form I-UD-V-SC (Version C.3)