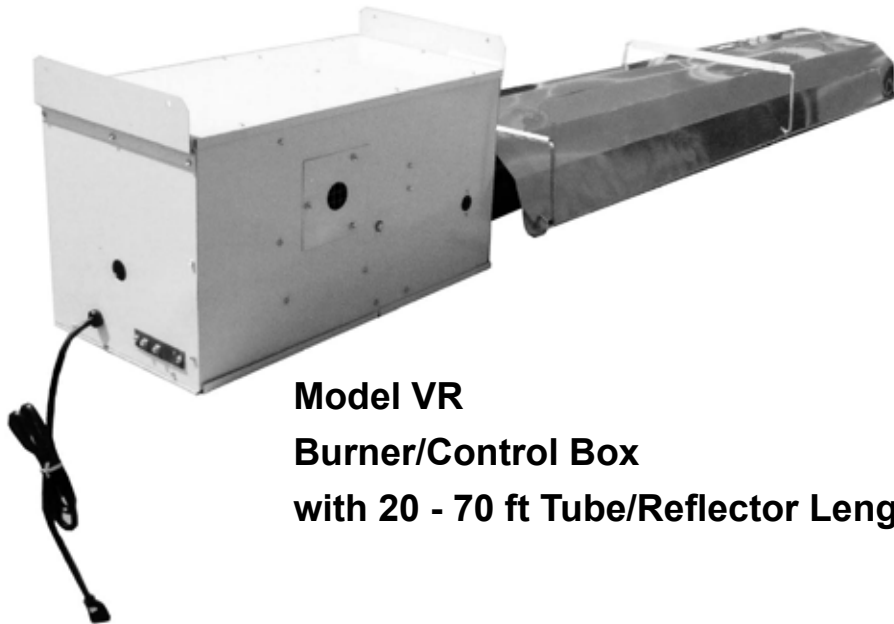


## INSTALLATION / OPERATION / MAINTENANCE

Applies to: **Model VR (std 60 Hz or optional 50 Hz) and Model GVR (std 50 Hz) Gas-Fired, Tubular, Radiant, Low-Intensity Infrared Heater**



**Model VR  
Burner/Control Box  
with 20 - 70 ft Tube/Reflector Length**



### FOR YOUR SAFETY

If you smell gas:

1. Open windows.
2. Don't touch electrical switches.
3. Extinguish any open flame.
4. Immediately call your gas supplier.

### FOR YOUR SAFETY

The use and storage of gasoline or other flammable vapors and liquids in open containers in the vicinity of this appliance is hazardous.

**WARNING:** Improper installation, adjustment, alteration, service, or maintenance can cause property damage, injury or death. Read the installation, operation, and maintenance instructions thoroughly before installing or servicing this equipment.

**WARNING:** Gas-fired appliances are not designed for use in hazardous atmospheres containing flammable vapors or combustible dust, in atmospheres containing chlorinated or halogenated hydrocarbons, or in applications with airborne silicone substances. See Hazard Levels, Page 2.

# Table of Contents

<b>1. General</b> .....	<b>2-3</b>
1.1 Cautions and Warnings .....	2
1.2 Warranty .....	3
1.3 Installation Codes .....	3
<b>2. Location</b> .....	<b>3-5</b>
<b>3. Uncrating/Packaging</b> .....	<b>5-6</b>
<b>4. Configurations, Dimensions, and Clearances</b> .....	<b>6-8</b>
4.1 Configuration Requirements .....	6
4.2 Dimensions .....	7
4.3 Clearances to Combustibles .....	8
<b>5. Suspension Requirements</b> .....	<b>8</b>
<b>6. Mechanical</b> .....	<b>9-31</b>
6.1 Prepare the Burner/Control Box .....	9
6.2 Assemble and Suspend the Heater .....	11
6.3 Gas Piping and Pressures .....	20
6.4 Venting and Combustion Air .....	24
<b>7. Electrical and Wiring</b> .....	<b>31-32</b>
7.1 Wiring Diagram .....	32
7.2 Control Thermostat .....	32
<b>8. Check Installation and Start-Up</b> .....	<b>33-34</b>
<b>9. Maintenance</b> .....	<b>35-39</b>
9.1 Maintenance Requirements .....	35
9.2 Maintenance Procedures .....	35
<b>10. Service</b> .....	<b>39-44</b>
10.1 Control Location, Operation, and Service .....	39
10.2 Troubleshooting .....	42
<b>Addendum</b> .....	<b>45-46</b>
Instructions for Attaching Double-Wall Vent Pipe (Type-B) .....	45
Model VR/GVR Technical Information .....	46
<b>Index</b> .....	<b>47</b>
<b>INSTALLER MUST COMPLETE THE FOLLOWING:</b> .....	<b>48</b>

## 1. General

Installation should be done by a qualified agency in accordance with the instructions in this manual and in compliance with all codes and requirements of authorities having jurisdiction.

### 1.1 Cautions and Warnings

There are warning labels on the unit and throughout this manual. For your safety, read the definitions below and comply with all boxes labeled **CAUTION**, **WARNING**, and **DANGER** during installation, operation, maintenance and service of this heater.

#### Definitions of Hazard Levels in this Manual

##### HAZARD INTENSITY LEVELS

- 1. DANGER:** Failure to comply will result in severe personal injury or death and/or property damage.
- 2. WARNING:** Failure to comply could result in severe personal injury or death and/or property damage.
- 3. CAUTION:** Failure to comply could result in minor personal injury and/or property damage.

---

**WARNING:** These tubular radiant heaters **DO NOT** qualify for explosion-proof installations.

---

**WARNING:** The installing contractor must be certain that the area where the heater is being installed does not contain corrosive or toxic fumes or that elements in the atmosphere do not produce corrosive or toxic fumes in the presence of an open flame.

The chlorine atmosphere in enclosed swimming pool areas may cause burner and tube corrosion if the area is not ventilated. ASHRAE design guides suggest a minimum of 5-6 air changes per hour. The manufacturer recommends outside combustion air. To provide outside combustion air, Option DE2, Combustion Air Inlet Kit, must be used.

---

## California Warning Label

If the heater is being installed in the state of California, the installer **MUST** attach a warning label on the outside of the unit. The California Warning Label is shipped in the owner's envelope along with this manual, the warranty form, and any other paperwork that applies.

If installation is in California, select a location on the rear of the burner box. Be sure the surface is clean and dry and adhere the label.

## Massachusetts Requirement

If the heater is being installed in the Commonwealth of Massachusetts, this unit must be installed by a licensed plumber or licensed gas fitter.

## 1.2 Warranty

Refer to limited warranty information on the warranty sheet in the "Owner's Envelope".

---

### **Warranty is void if ....**

- a. Wiring is not in accordance with the diagram furnished with the heater.
  - b. The unit is installed without proper clearance to combustible materials.
- 

## 1.3 Installation Codes

These units must be installed in accordance with local building codes. In the absence of local codes, in the United States, the unit must be installed in accordance with the National Fuel Gas Code NFPA54/ANSI Z223.1 (latest edition). A Canadian installation must be in accordance with the Natural Gas and Propane Installation Code CAN/CSA B149.1 (latest edition). These codes are available from CSA Information Services, 1-800-463-6727. Local authorities having jurisdiction should be consulted before installation is made to verify local codes and installation procedure requirements.

All electrical wiring must be in accordance with the National Electric Code NFPA NO. 70 (latest edition) or, in Canada, the Canadian Electrical Code, part I-CSA C22.1.

The installing contractor must be familiar with all of the various requirements and is responsible for installing this heater in compliance with the applicable codes.

### **Special Installations --**

**Aircraft Hangars:** In the United States, the heaters must be installed in accordance with NFPA 409 (latest edition). NFPA Publications are available from the National Fire Protection Association, 1 Batterymarch Park, Quincy, MA 02169. In Canada, installation in an aircraft hangar must comply with CAN/CSA-B149.1. Both NFPA 409 and the CAN/CSA-B149.1 specify that the heater shall not be located in an area of an aircraft hangar where it may be subjected to physical damage by aircraft, cranes, moveable scaffolding, or other objects.

NFPA 409 specifies a clearance of 10 feet (3M) to the bottom of the heater from the highest surface of the wings or engine enclosures of the highest aircraft which may be housed in the hangar. NFPA 409 and CAN/CSA B149.1 specify a minimum clearance of eight feet (2.4M) from the floor to the heater in other sections, such as offices, or shops, that communicate with the aircraft hangar.

**Parking Structures:** In the United States, heaters installed in parking structures must be in accordance with NFPA 88A (latest edition).

---

**WARNING: Minimum clearance marked on the heater must be maintained from vehicles parked under the heater.**

---

## 2. Location

When selecting the installation location, major factors to consider are **(1) Personal and Property Safety, (2) Personal Comfort, and (3) Heating Efficiency**

**(1) Safety** - The location must meet the Installation Codes listed in Paragraph 1 and any local codes. These heaters are approved for indoor commercial/indus-

## 2. Location (cont'd)

trial installations only. Do not install these tubular radiant heaters in areas that contain corrosive or toxic fumes or where elements in the atmosphere could produce corrosive or toxic fumes in the presence of an open flame. These heaters do not qualify for explosion-proof installations.

Clearance to combustibles must be observed (See Paragraph 5), including clearances to stock that might be periodically stacked underneath the heater.

The supporting structure must have a load-carrying capacity of at least 200 lbs (91 kg).

Do not locate the heater above or too close to electric lines, gas pipes, emergency sprinkler systems, or any such structures that could be adversely affected by radiant or convection heat.

Do not locate the heater where it could be damaged by high lifts, cranes, or any other such equipment.

Since chain suspension is required to allow for expansion and contraction of the tubes, proper positioning near large door openings is important. If the heater is being installed near a large door (ex: garage, loading dock, aircraft hangar, etc.), position the heater so that it will not "swing" in the wind. Lateral movement of the tubular system should be limited.

**(2) Comfort** - Because of the unique heat transfer features of an infrared heater, the comfort quality of the heat is greatly affected by the location of the heater. Rays of heat are emitted from the surface of the tubes and directed by the reflectors. When radiant heat rays reach a surface, those rays are absorbed, raising the temperature of that "object". Since infrared heat does not heat the air, a comfort advantage is that stratification does not occur. When the rays are not obstructed from reaching the floor, the floor and lower level areas maintain a more comfortable temperature than with convection (warm air) heating equipment.

For optimum comfort when infrared heaters are being used to "heat" personnel (spot heating), it is recommended that (1) the rays of heat be directed toward the person(s) from an angle rather than from directly overhead, and (2) the heater(s) be arranged so that rays are directed against at least two sides (or front and back) of the person(s). If the heater must be hung directly overhead, a higher mounting height will increase the comfort level because the greater distance will decrease the intensity level of the rays. **Another significant factor when locating the heater in relation to people is that the heat emitted from the burner/combustion chamber end of the tubular infrared heater is more intense than the heat emitted from the exhaust end. For this reason, a U-tube configuration is often best suited for overhead spot heating applications.**

Tubular radiant heaters are engineered to provide comfort-level personal spot and space heating, but each application should be designed individually to determine the best, quality-comfort locations.

**(3) Efficiency** - Because of the unique features of radiant heat transfer, selecting the most efficient location for infrared equipment depends on the "floor" coverage of the emitted heat rays. Floor coverage distance can be figured as approximately two times the mounting height of the unit. However, comfort level heating depends on the infrared intensity, and intensity levels decrease with higher mounting heights and greater floor coverage.

For space heating infrared applications, the location of the units must be evaluated as part of the heater size selection. Determine the total BTU's required, the floor coverage required, and the mounting height. From this information design a heater size and location plan that will provide the most complete floor coverage without excessive overlapping. In most cases, perimeter heaters

should be located parallel to the wall. The distance from the wall is determined by whether the reflectors will be angled or horizontal.

For spot heating applications, the tubular system should be located to direct the rays toward the area requiring heat. Depending on the installation, this can be done from directly overhead or reflector angled from the side. U-tube configurations are often best suited for overhead spot heating applications. Refer to the recommended minimum mounting heights below. Use the mounting height, the size of the heater, the heater configuration, and the application conditions to determine the most efficient location of the heater.

**Mounting Height Table**

Recommended Minimum Mounting Height														
Reflector Position	Models VR/GVR, Size (000 BTUH Input)													
	50		75		100		125		150		175		200	
	feet	M	feet	M	feet	M	feet	M	feet	M	feet	M	feet	M
Horizontal	11	3.4	12	3.7	13	4.0	15	4.6	16	4.9	17	5.2	18	5.5
30° Angle	9	2.7	10	3.0	11	3.4	13	4.0	14	4.3	15	4.6	16	4.9
45° Angle	8	2.4	9	2.7	10	3.0	11	3.4	13	4.0	14	4.3	15	4.6

### 3. Uncrating/ Packaging

Check for shipping damage. If any damage is found, document the damage with the shipping agency and immediately contact your Distributor. If you are an authorized Distributor, follow the FOB freight policy procedures provided by Thomas & Betts for this product.

Because of their modular design, these heaters are packaged in sections and require field assembly. The burner/control box is in one carton, and the tubes are packaged in one, two, or three cartons depending on the length of the system. Each shipped-separate option has its own carton. Be sure all parts are at the site before beginning installation.

**Burner/Control Box Carton** - For the convenience of both the stocking and the non-stocking distributor, Model VR burner/control boxes have two different packaging schemes. **Read carefully to determine whether or not the burner/control box requires field conversion before being installed.** Model GVR burner/control box is available in specific sizes only.

#### (1) Burner/Control Box with Conversion Package - Model VR, 60 Hz only

Package	Contents
<b>VR 50</b>	Factory-assembled Size 50,000 BTUH heater
<b>VR 75/100</b>	Factory-assembled Size 75,000 BTUH heater Conversion kit to change to a Size 100,000 BTUH heater
<b>VR 125/150</b>	Factory-assembled Size 125,000 BTUH heater Conversion kit to change to a Size 150,000 BTUH heater
<b>VR175/200</b>	Factory-assembled Size 175,000 BTUH heater Conversion kit to change to a Size 200,000 BTUH heater

#### (2) Burner/Control Box Factory Built to a Specific Size (Models VR & GVR)

- If the burner/control box carton does not have a label about field conversion, the carton contains a burner/control box factory-built to a specific size. Check the rating plate to verify size and type of gas.

**Tube Cartons (Models VR & GVR)** - Tubes are also packaged so that a minimum number of cartons will cover all lengths of heater systems. This package identification system applies to all heaters, whether shipped from distributor stock or shipped to order from the factory. Before beginning installation, verify that the packages at the job site match the length of heater being installed.

Reflectors, wire reflector retainers, hanger bars, tube brackets, compression couplings, and hardware bags with required reflector and tube hardware are included in each carton.

### 3. Uncrating/ Packaging (cont'd)

**Important NOTE:** Before installation, wipe any excess corrosion inhibitor from the heat exchanger tubes. Failure to do so could result in excessive smoke from the surface of the tubes on first startup.

(NOTE: Chain for hanging is not included. Use either an optional hanger kit (Option CK11) and/or a turnbuckle kit (Option CK12-18) or field-supplied hardware. See suspension requirements in Paragraph 5.)

Packaging Scheme for 10' Straight Tubes								
Pkg ID*	Pkg P/N	Contents						
VRE	205204	(1) Combustion Chamber Tube; (1) Heat Exchanger Tube						
VRF	205205	(1) Combustion Chamber Tube; (2) Heat Exchanger Tubes						
VRG	205206	(2) Heat Exchanger Tubes						
VRH	205151	(3) Heat Exchanger Tubes						
Tube Packages Required by Length of System					Each tube package includes required hardware for tubes and reflectors. Extra hardware packages are available as parts.			
Length	Qty	Pkg P/N	Qty	Pkg P/N	Pkg ID	Pkg P/N	Hardware Pkg	
20 ft system requires	1	205204	--	--				
30 ft system requires	1	205205	--	--				
40 ft system requires	1	205204	1	205206	VRE	205204	P/N 209401	
50 ft system requires	1	205204	1	205151	VRF	205205	P/N 209402	
60 ft system requires	1	205205	1	205151	VRG	205206	P/N 209403	
70 ft system requires	1	205205	2	205206	VRH	205151	P/N 209404	

**FIGURE 1 - Tube Cartons include Tubes, Reflectors, Hangers, Brackets, Couplings, and Hardware**



\*Tube Package ID is the same for Model VR and Model GVR heaters.

**Accessory Cartons** - All field-installed options are shipped in separate cartons. Be sure all parts are at the installation site.

## 4. Configurations, Dimensions, and Clearances

### 4.1 Configuration Requirements

Refer to Form T-VR-CNFG (available from your distributor), for a layout view of all allowable configurations.

**WARNING: Do not install a heater in a length or configuration that is not permissible for the Size. See Hazard Levels, page 2.**

Depending on the length and size of the heater, the heat exchanger sections may be installed in various configurations. Optional "L"-shaped, 5-foot, and "U"-shaped heat exchanger tubes are available to adapt the heaters to these configurations (Option UC2 for "L"; Option UB3 for "U"; Option UA1 for 5-foot heat exchanger tube).

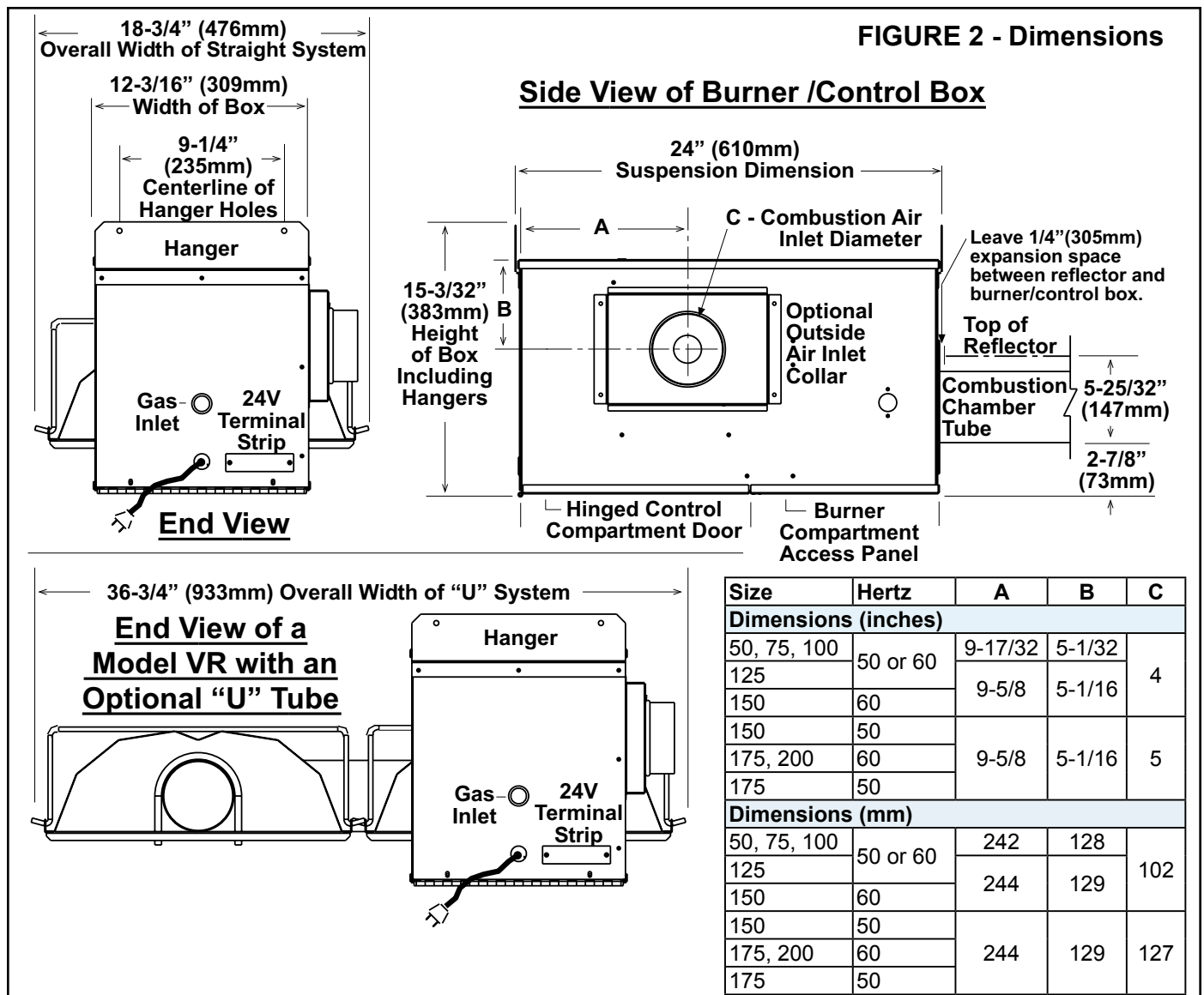
Model VR/GVR heaters may be installed in the configuration lengths shown in the table on page 7. Only straight tubes are used to identify length. The combustion chamber is always the first 10 ft (3.1M) length. The straight heat exchanger tubes represent each additional 10-ft (3.1M) or 5-ft (1.5M)

**Comply with the requirements listed below and the lengths in the table.**

- **Sizes 100 and 125 require** 15 ft (4.6M) of straight tube length before installing an optional "U" or an "L" tube.
- **Size 150 requires** 20 ft (6.1M) of straight tube length before installing an optional "U", "L", or 5-ft (1.5M) tube.
- **Sizes 175 and 200 require** 30 ft (9.1M) of straight tube length before installing an optional "U", "L", or 5-ft (1.5M) tube.
- Maximum of one "U" tube per system (do not use with "L" tubes).
- Maximum of two "L" tubes per system (do not use with "U" tube)
- Maximum of two 5-ft (1.5M) tubes; 5-ft tubes may be used in a layout with a "U" or "L" tube
- On a "U" configuration, the straight tube length on the burner side of the "U" must be equal to or longer than the tube length on the exhaust side.
- Exhaust tube must always be a 10-ft (3M) tube.

Size	Configuration				
	Straight	With "U" Or "L" Tube	With 2 "L" Tubes	Straight With 5-ft Tube	With 5-ft Tube(s) & "U" Or "L" Tube
<b>Allowable Straight Lengths by Size and Configuration (feet)</b>					
50	20, 30, 40	20, 30, 40	20, 30, 40	25, 35	25, 30, 35, 40
75	20, 30, 40	20, 30, 40	20, 30, 40	25, 35	25, 30, 35, 40
100	30, 40, 50	30, 40, 50	30, 40, 50	35, 45	30, 35, 40, 45, 50
125	30, 40, 50, 60	30, 40, 50, 60	30, 40, 50, 60	35, 45, 55	30, 35, 40, 45, 50, 55, 60
150	40, 50, 60	40, 50, 60	40, 50, 60	45, 55	40, 45, 50, 55, 60
175	40, 50, 60, 70	40, 50, 60, 70	40, 50, 60, 70	45, 55, 65	45, 50, 55, 60, 65, 70
200	50, 60, 70	50, 60, 70	50, 60, 70	55, 65	50, 55, 60, 65, 70
<b>Allowable Straight Lengths by Size and Configuration (meters)</b>					
50	6.1, 9.1, 12.2	6.1, 9.1, 12.2	6.1, 9.1, 12.2	7.6, 10.7	7.6, 9.1, 10.7, 12.2
75	6.1, 9.1, 12.2	6.1, 9.1, 12.2	6.1, 9.1, 12.2	7.6, 10.7	7.6, 9.1, 10.7, 12.2
100	9.1, 12.2, 15.2	9.1, 12.2, 15.2	12.2, 15.2	10.7, 13.7	9.1, 10.7, 13.7, 15.2
125	9.1, 12.2, 15.2, 18.3	9.1, 12.2, 15.2, 18.3	9.1, 12.2, 15.2, 18.3	10.7, 13.7, 16.8	9.1, 10.7, 12.2, 13.7, 15.2, 16.8, 18.3
150	12.2, 15.2, 18.3	12.2, 15.2, 18.3	12.2, 15.2, 18.3	13.7, 16.8	12.2, 13.7, 15.2, 16.8, 18.3
175	12.2, 15.2, 18.3, 21.3	12.2, 15.2, 18.3, 21.3	12.2, 15.2, 18.3, 21.3	13.7, 16.8, 19.8	13.7, 15.2, 16.8, 18.3, 19.8, 21.3
200	15.2, 18.3, 21.3	15.2, 18.3, 21.3	15.2, 18.3, 21.3	13.7, 16.8, 19.8	15.2, 16.8, 18.3, 19.8, 21.3

## 4.2 Dimensions



## 4. Dimensions, Configurations, and Clearances (cont'd)

### 4.3 Clearances to Combustibles

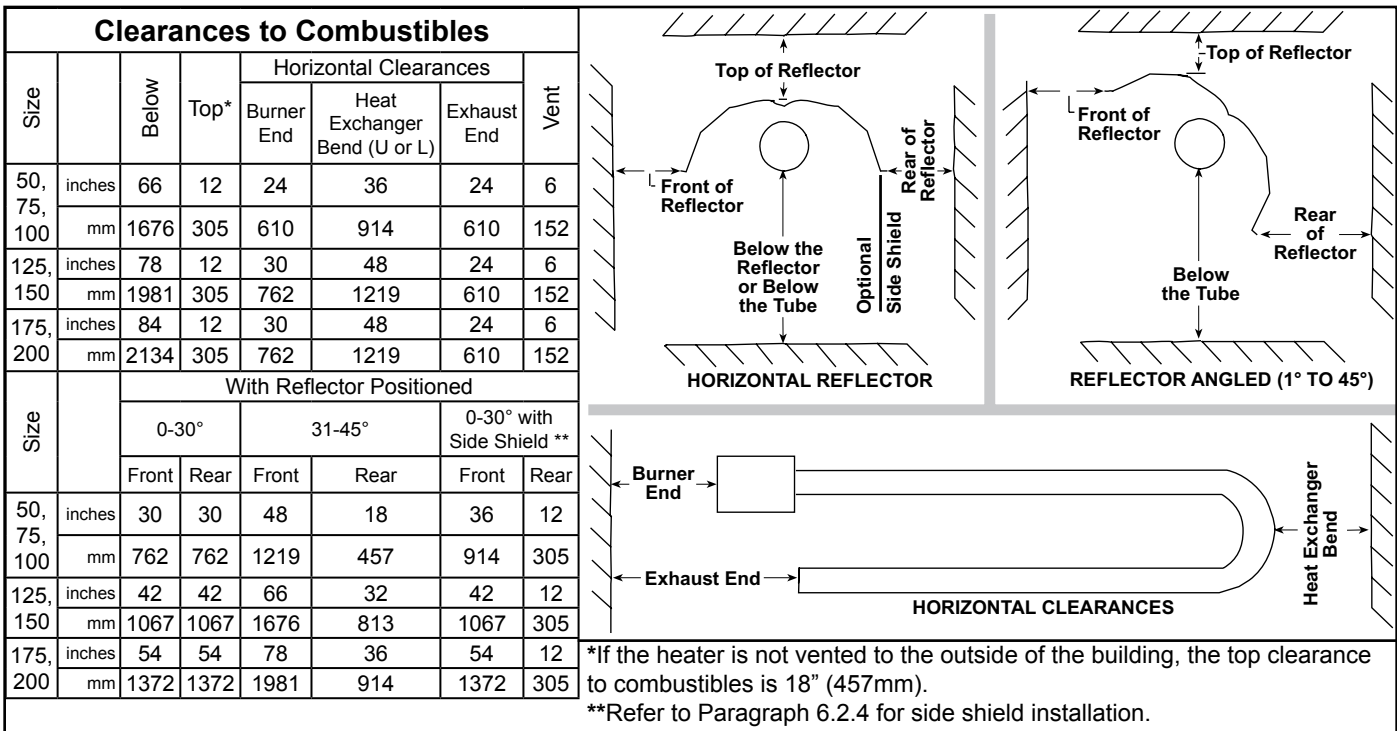
Required clearances depend on the size of the heater (BTUH input), the position of the reflector, and the addition of an optional side shield on the rear side of the heater. Refer to illustrations in **FIGURE 3** to define clearances.

The stated clearance to combustibles represents a surface temperature of 90°F (32°C) above room temperature. Building materials with a low heat tolerance (such as plastics, vinyl siding, canvas, tri-ply, etc.) may be subject to degradation at lower temperatures. It is the installer's responsibility to assure that adjacent materials are not subject to degradation.

The clearances listed in the tables are installation requirements. In addition, ANSI Z-223-1, Section 6.18, requires that signs be posted specifying the maximum permissible stacking heights to assure that the required clearances from the heater to combustibles are maintained in areas where items are stored under the heater.

**FIGURE 3 - Clearance Orientation**

Refer to Paragraph 1, Special Installations, for specific clearance requirements for heaters installed in aircraft hangars and public garages.



## 5. Suspension Requirements

Model VR/GVR heaters are assembled as they are suspended. Suspension and field assembly are the responsibility of the installer. Comply with the requirements listed here and the instructions in Paragraph 6.

- Supporting structure must have a minimum load-carrying capacity of 200 lbs (91 kg). (**Do not** suspend the heater from gas piping or electrical conduit.)
- Clearances to combustibles must be observed. See Paragraph 4.3.
- Heater must be suspended by hanging chains. Chain must have a minimum of 200 lbs (91kg) working load rating. Use either Option CK11 hanging chain kit which includes 50 ft of chain and 22 "S" hooks or equivalent field-supplied chain and "S" hooks.

Chain length (including turnbuckle, if used) must be a minimum of 12 inches (305mm) at each suspension point. All chains must be plumb. Model VR/GVR tubular radiant heaters must be suspended with chain because the tubes will expand when heated. The overall length of a straight system will expand approximately as shown in the table.

Straight System Length		Expansion	
ft	M	inches	mm
70 ft	21.3	2-3/4	70
60 ft	18.3	2-3/8	60
50 ft	15.2	2-1/8	54
40 ft	12.2	1-7/8	48
30 ft	9.1	1-1/2	38
20 ft	6.1	1-1/8	29

- Each straight tube section must have a suspension point. Straight sections adjacent downstream to a “U” or “L” tube require two suspension points.
- There must be a suspension point within 12 inches (305mm) of every coupler.
- Since the heater must be level, a turnbuckle is recommended at each suspension point. Turnbuckles must be of steel or malleable iron. Use either an optional turnbuckle kit or field-supplied equivalent. Turnbuckle Option 15-22 Kits include the quantity of turnbuckles required by length of heater.
- Refer to Paragraph 2 for recommended minimum mounting heights. The installer is responsible for properly and adequately fastening the chains to the building and supporting the weight of the heater. Depending on the type of building construction, either attach the chain support directly to the building or attach and extend a support to the location needed. SUPER-STRUT® brackets or a comparable metal strut material is well suited as a support structure that requires numerous suspension points.

## 6. Mechanical

### 6.1 Prepare the Burner/Control Box

There are very important steps that must be followed to prepare, assemble, and suspend these tubular radiant heaters. Preparing the heater, suspension, and field assembly are the responsibility of the installer. Follow all instructions carefully.

All burner/control boxes require some field preparation. The type of preparation depends on how the unit was ordered and where it will be installed. Determine which of these two situations match your application and follow the appropriate instructions. (Refer to Paragraph 3 for explanation on packaging.)

- **The unit was ordered as a specific size QR as a VR 75/100, VR 125/150, or VR 175/200 and is being installed as a Size 75, 125, or 175.** Proceed to **STEP 2)** of the Preparation Instructions. (Skip **STEP 1)**.)
- **The unit was ordered as a VR 75/100, VR 125/150, or VR 175/200 and is being installed as a Size 100, 150, or 200.** Proceed to **STEP 1)** of the Preparation Instructions. Complete both **STEP 1 and 2)**.

### Preparation INSTRUCTIONS:

#### **STEP 1) Change Components to Field Convert the Model VR Burner/Control Box Size 75,000 to 100,000; Size 125,000 to 150,000; or Size 175,000 to 200,000.**

**Parts Required:** Conversion kit shipped with the burner/control box. All kits include a burner orifice, a combustion air restrictor plate, and conversion label. A Size 200 kit also includes a pressure switch.

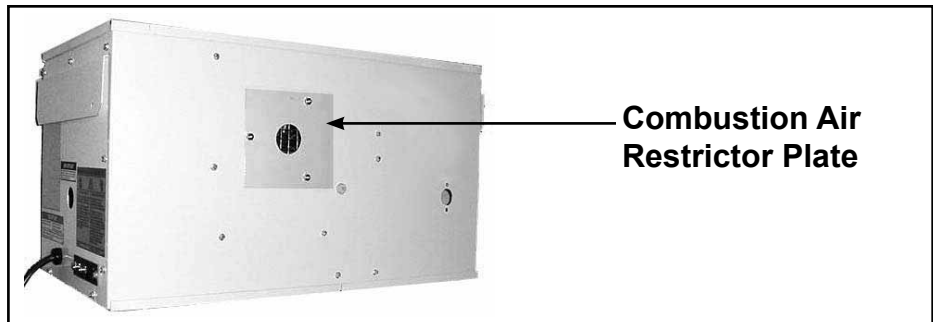
- 1. Conversion Size Label** - Fill-in the label stating that the burner/control box has been converted to either a Size 100,000, 150,000 or 200,000.
- 2. Change Air Restrictor Plate** - Refer to **FIGURE 4** and identify the combustion air restrictor plate on the side of the burner box. Remove the three or four nuts holding the factory-installed restrictor plate; save the nuts and discard the restrictor plate. Using the same nuts, attach the combustion air restrictor plate shipped in the parts bag.

## 6. Mechanical (cont'd)

### 6.1 Prepare the Burner/Control Box (cont'd)

#### FIGURE 4 - Change the Combustion Air Restrictor Plate

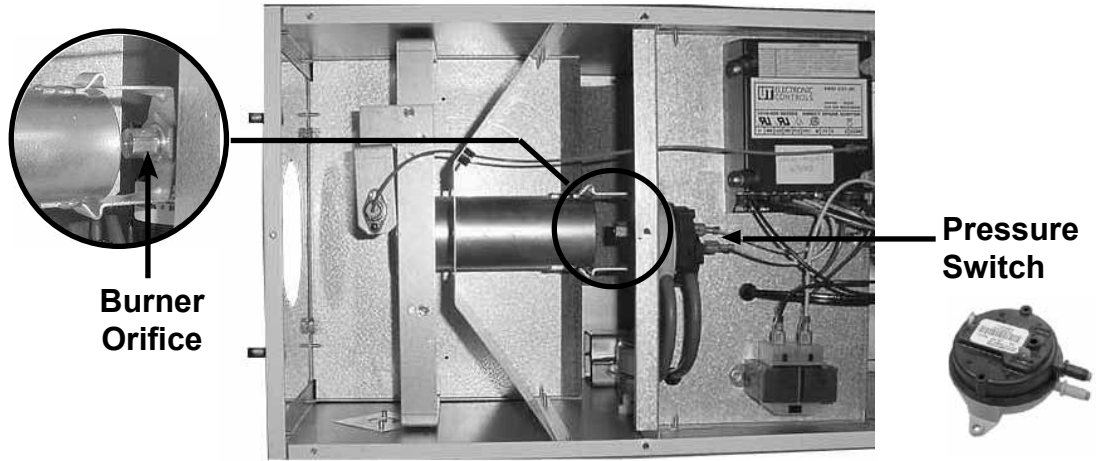
- **1st**, remove and discard the factory installed restrictor plate. (Save the nuts.)
- **2nd**, attach the restrictor plate from the conversion parts bag.



3. **Change Burner Orifice** - Open both access panels on the bottom of the burner/control box. Locate the burner orifice (See **FIGURE 5**).

#### FIGURE 5 - Change the Burner Orifice

Bottom View



Using a 9/16" open-end wrench, remove and discard the factory-installed burner orifice. Install the burner orifice shipped in the conversion package.

4. **Model VR Size 200 Only** - On a Size 200, change the pressure switch.

#### Instructions for Changing Pressure Switch

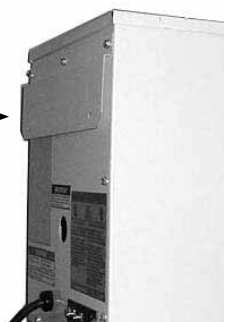
- a) In the control compartment, locate the pressure switch (See **FIGURE 5**).
  - b) Mark and disconnect the two wires attached to the pressure switch.
  - c) Disconnect the rubber tubing from the pressure switch.
  - d) Remove the pressure switch. Using the same screws, install the Size 200 pressure switch. Attach the rubber tubing and wires.
5. Close the bottom panels. Adhere the label to the rear of the burner/control box adjacent to the rating plate.

#### STEP 2) Re-position the Burner Box Hangers

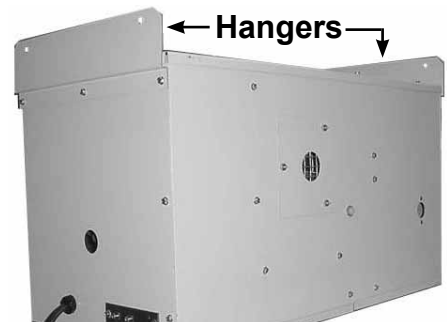
1. See **FIGURE 6A**. Locate and remove the three screws retaining the two burner box hangers (one hanger one each end).
2. See **FIGURE 6B**. Using the screws that were removed, re-attach the two burner box hangers as illustrated.

#### FIGURE 6A - Shipping Position of Box Hangers

Hanger in Shipping Position →



#### FIGURE 6B - Attach hangers for installation.



**Additional Burner Box Preparation for Operation Above 6000 ft (1830M)**

If a Model VR/GVR 50-175 is being installed at an altitude above 6000 ft (1830M), the pressure switch will have to be changed. If ordered with the unit as Option DJ20, the pressure switch is shipped separately. (**NOTE:** Model VR200 does not require a pressure switch change above 6000 ft/1830M.)

**FIGURE 7 - High Altitude Pressure Switch is Required above 6000 ft (1830 M) Elevation on Sizes 50-175**



High Altitude Pressure Switches (Option DJ20 required above 6000 ft/1830M)									
Model	VR and GVR			VR			VR and GVR		
Size	50	75	100	125	150	175	125	150	175
Electrical Frequency	50 Hz or 60 Hz			60 Hz			50 Hz		
Option DJ20 Package P/N	205524			205525			258817	258818	258819
High Altitude Switch P/N	205445			205446			197030	203932	205444
Differential OFF Setpoint (" w.c.)	0.15			0.70			0.40	0.25	0.30
Label Color	Gray			Pink			Green		

**Instructions for Changing Pressure Switch**

1. In the control compartment, locate the pressure switch (See **FIGURE 5**.)
2. Mark and disconnect the two wires attached to the pressure switch.
3. Disconnect the rubber tubing attached to the pressure switch.
4. Using the same screws, install the high altitude pressure switch for the size of heater being installed. Attach the rubber tubing and wires.

Gas valve adjustment is required for all high altitude operation and can only be done after the heater is installed. Follow the instructions in Paragraph 6.3.

**6.2 Assemble and Suspend the Heater**

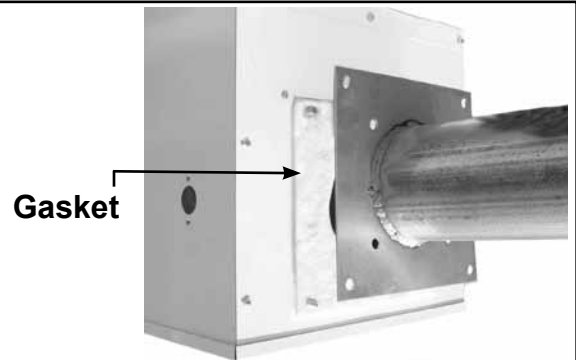
**6.2.1 Assemble the Burner/Control Box and the Combustion Chamber Tube**

Use these parts (from the hardware bag) to assemble the burner/control box and the combustion chamber tube: Gasket, P/N 116029; (4) Lockwashers, P/N 1333; (4) Nuts, P/N 6554.

Identify the combustion chamber tube (the aluminized tube with the square flange on one end). Follow the instructions to attach the combustion chamber tube to the burner/control box (See **FIGURE 8**).

**FIGURE 8 - Attach the Combustion Chamber Tube to the Burner/Control Box**

- a) Slide the **gasket** over the studs on the burner/control box.
- b) Slide the flange over the bolts.
- c) Use the washers and nuts to attach the combustion chamber flange securely to the burner/control box.



**6.2.2 Suspend the Assembled Burner/Control Box and Combustion Chamber Tube**

1. **Determine location of two combustion chamber tube suspension points** -- one close to the burner/control box and one within 12" (305mm) of the coupler that will connect it to the first heat exchanger tube. Install a tube bracket at each suspension point (See **FIGURES 9 and 10**). Slide the threaded "U" bolt over the tube and through the bracket; attach with nuts. (**NOTE:** Nuts must be secure before heater is operated, but if the reflector is going to be rotated, nuts may be installed loosely now and tightened later.)  
Hook the wire retainer out through the ends of the tube bracket. (**NOTE:** One "hook" of the wire retainer is bent 75° and the other 45°. If the reflector is going to be rotated, be sure the side with the sharper 45° bend will be at the lower side.)

## 6. Mechanical (cont'd)

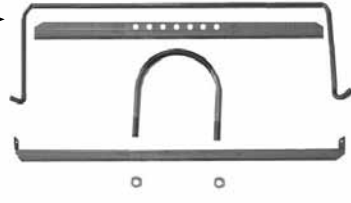
### 6.2 Assemble and Suspend the Heater (cont'd)

**NOTE:** One "hook" of the wire retainer is bent 75° and the other 45°. If the reflector is going to be rotated, be sure the side with the 45° bend will be at the lower side.

### 6.2.2 Suspend the Assembled Burner/Control Box and Combustion Chamber Tube (cont'd)

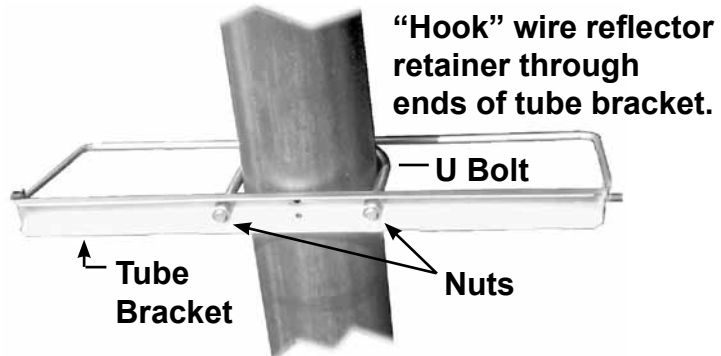
**FIGURE 9 - Wire Reflector Retainer, Hanger Bar, and Tube Bracket**

Wire Reflector Retainer and Hanger Bar



Tube Bracket and Hardware (U-bolt and nuts) - wire retainer hooks through ends of bracket

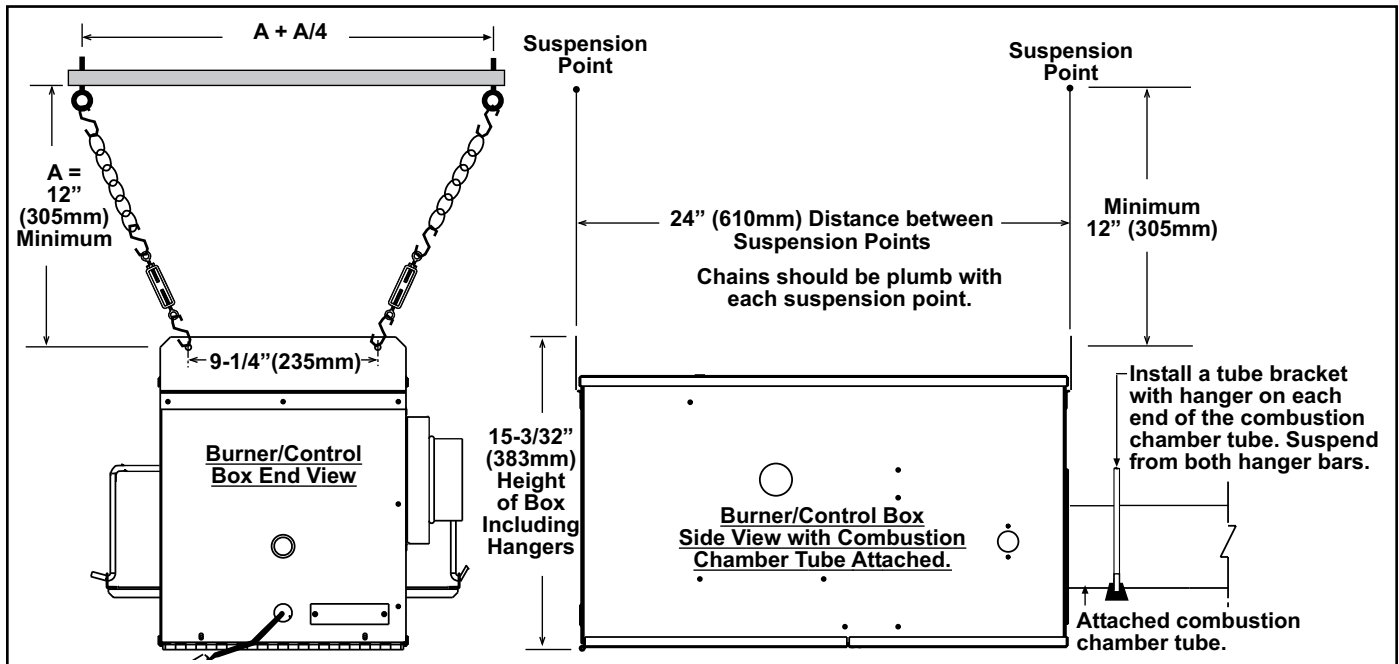
**FIGURE 10 - Bottom View with Wire Reflector Retainer and Tube Bracket Installed (Hanger bar is not illustrated.)**



### 2. Suspension of the Burner/Control Box (See FIGURE 11.)

Attach the four "S" hooks to the hanger brackets on the burner control box. Suspend the box as illustrated in FIGURE 11. Keep all chains plumb with the hanger and suspension point. **NOTE:** Use of turnbuckles is recommended for leveling.

**FIGURE 11 - Suspend the Burner Control Box (with Combustion Chamber Tube attached)**

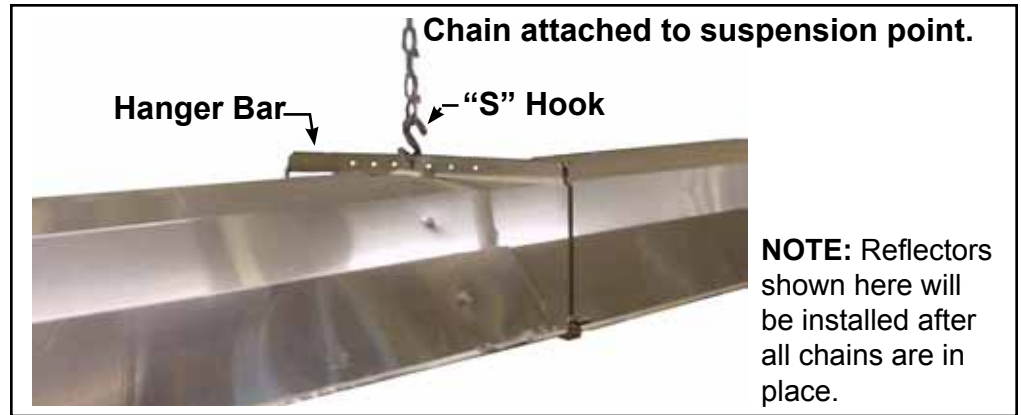


### 3. Suspension of the Combustion Chamber Tube

Slide the hanger bar up over the reflector retainer wire. Attach an "S" hook at the center hole in the bar. Attach a turnbuckle or chain to the "S" hook. Using a turnbuckle is recommended for leveling.

If the installation is going to be horizontal and a turnbuckle has been used, close the "S" hooks. If the reflector is going to be angled or there is no turnbuckle, leave the "S" hooks open until after the system is leveled.

**FIGURE 12 - Attaching Hanging Chain at Tube Suspension Points**

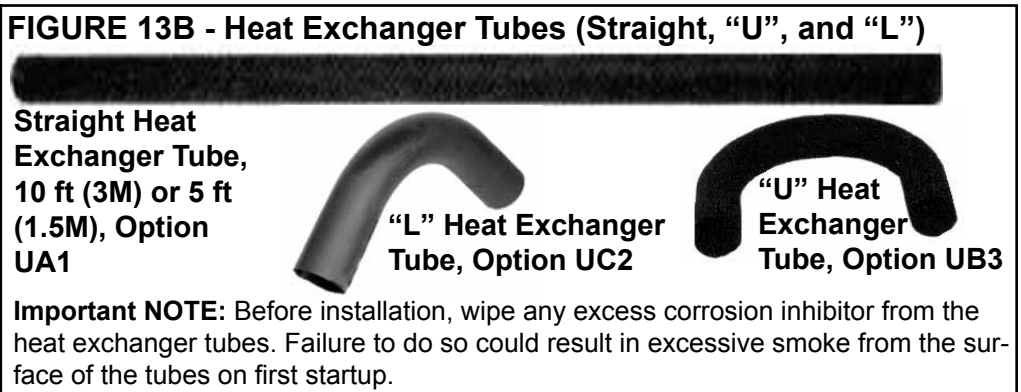
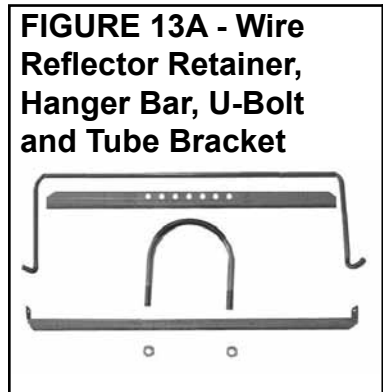


**6.2.3 Install the Heat Exchanger Tubes and Turbulator Strip Sections**

Refer to illustrations in FIGURES as noted. Follow Steps in order.

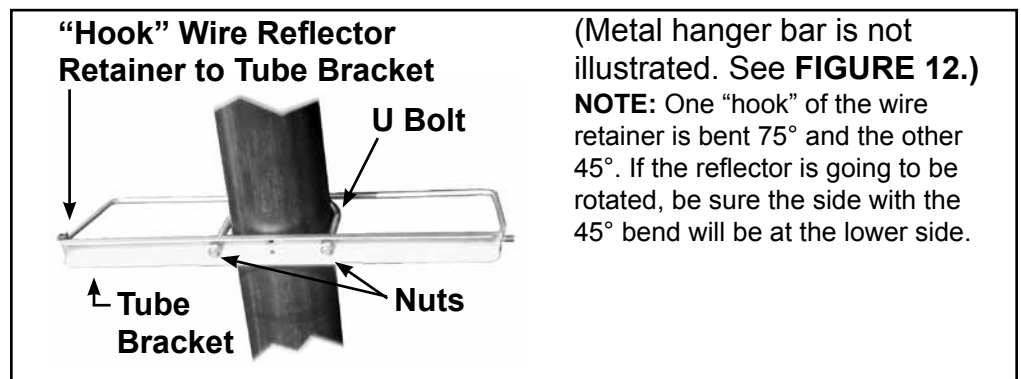
There are very important steps that must be followed to suspend and assemble this tubular radiant heater. Suspension and field assembly are the responsibility of the installer. Follow all instructions carefully.

1. Identify the heat exchanger tubes and parts packaged with them (Refer to the illustrations in FIGURES 13A-13D).
2. **Install the First Heat Exchanger Tube**
  - a) Determine if the first heat exchanger tube is straight, "U", or "L". (See configuration requirements, Paragraph 4.1, for placement of 5-ft, "U" or "L" tubes.) If the first tube is a "U" or "L", follow the instructions shipped with the option package.



If installing a straight tube, prepare the tube by attaching a tube bracket (See FIGURE 14.) within 12" (305mm) of the downstream end of the tube. Slide the threaded "U" bolt over the tube and through the bracket; attach

**FIGURE 14 - Attach the tube bracket and wire reflector retainer to the heat exchanger tube.**



## 6. Mechanical (cont'd)

### 6.2 Assemble and Suspend the Heater (cont'd)

Refer to illustrations in FIGURES as noted. Follow Steps in order.

FIGURE 15 - Connect Combustion Chamber and Heat Exchanger Tube with Compression Coupling

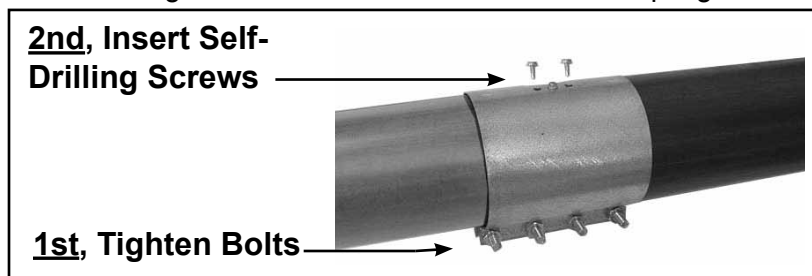
#### 6.2.3 Install the Heat Exchanger Tubes and Turbulator Strip Sections (cont'd)

with nuts. (NOTE: Nuts must be secure before heater is operated, but if the reflector is going to be rotated, nuts may be installed loosely now and tightened later.)

Hook the wire retainer out through the ends of the tube bracket. (NOTE: One "hook" of the wire retainer is bent 75° and the other 45°. If the reflector is going to be rotated, be sure the side with the sharper 45° bend will be at the lower side.)

Slide the hanger bar over the reflector retainer wire. Attach an "S" hook at the center hole in the bar (See FIGURE 12). Connect the chain or turnbuckle from the next suspension point to the "S" hook. Using a turnbuckle is recommended for leveling.

- b) With the bolts toward the bottom, slide the compression coupling onto the end of the suspended combustion chamber tube. Slide the end of the first heat exchanger tube into the other side of the coupling. See FIGURE 15.



With both tube ends as far into the coupling as they will go, tighten the coupling bolts. In the top, insert the two self-drilling screws to secure the coupling to each tube. Use the same procedure to join all heat exchanger tubes. Tubes must be suspended as they are installed.

3. Repeat the instructions in **Step No. 2 above** to suspend and join all of the remaining heat exchanger tubes. If installing a "U" or "L" tube, a compression coupling is used for tube connections but refer to the instructions in the option package for additional information. Straight tubes adjacent downstream of a "U" or "L" tube require two suspension points.

**NOTE:** If your configuration requires a turbulator strip before a "U" or "L" tube, insert the turbulator strip before the "U" or "L" tube is connected. Follow the instructions in **Step No. 4**, and install two sections of turbulator strip. (This will only occur when installing a 40' to 70' system in a configuration where a "U" or "L" tube connects directly to the exhaust heat exchanger tube.)

#### 4. Install the Turbulator Strip

Locate turbulator strip sections. Install a turbulator strip in a tube **only after it has been suspended and connected to the previous tube**. Refer to FIGURES 16A and 16B. Install the turbulator strip by sliding a section into the tube, connecting the next section, and sliding the connected sections on into the tube(s).

Refer to the Turbulator Requirements chart to determine the quantity of turbulator sections required and when and where they should be installed.

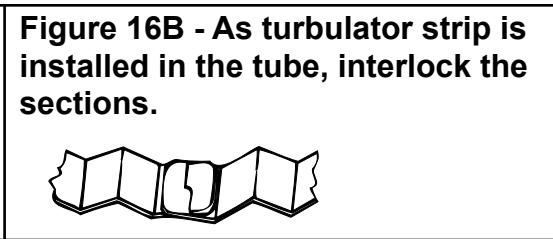
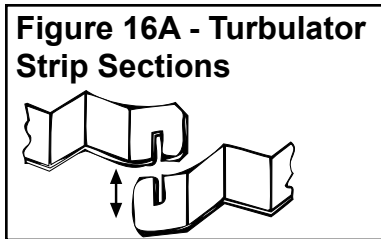
---

**CAUTION: Except for in a 20-ft straight system, turbulator strips must never be allowed to slide into the combustion chamber. Verify correct usage of the turbulator strip(s); see Turbulator Requirements table on page 15.**

---

**FIGURES 16A and 16B - Interlocking Turbulator Strip Sections**

**Turbulator Requirements**



Length of Straight Tubes	BTUH Size (000)	Configuration (See Requirements in Paragraph 6; allowable layouts are illustrated in Form T-VR-CNFG.)	Turbulator Sections (Some sections may not be used; follow instructions.)			
			In Tube Packages	Used in the Configuration	Quantity and WHEN to Install (same for all elevations)	WHERE to Install
			Number of Sections (qty)			
20 ft	50, 75	Straight	4	4	4 sections after exhaust heat exchanger tube is connected	Into exhaust heat exchanger tube
		"U" or "L"	4	3	3 sections after exhaust heat exchanger tube is connected	Into exhaust heat exchanger tube
25 ft	50, 75, 100	All	4	3	3 sections after exhaust heat exchanger tube is connected	Into exhaust heat exchanger tube
30 ft	50, 75, 100, 125	All	3	3	3 sections after exhaust heat exchanger tube is connected	Into exhaust heat exchanger tube
35 ft	50, 75, 100, 125	All	3	3	3 sections after exhaust heat exchanger tube is connected	Into exhaust heat exchanger tube
40 ft	50, 75, 100, 125, 150, 175	Straight heat exchanger tube adjacent to the exhaust heat exchanger tube (See FIGURE 17A)	5	5	5 sections after exhaust heat exchanger tube is connected	Into exhaust heat exchanger tube
		"U" or "L" tube adjacent to the exhaust heat exchanger tube (See FIGURE 17B)	5	5	2 sections <i>before</i> "U" or "L" is connected 3 sections after exhaust heat exchanger tube is connected	Into end of straight tube before "U" or "L" Into exhaust heat exchanger tube
45 ft	100, 125, 150, 175, 200	Straight heat exchanger tube adjacent to the exhaust heat exchanger tube (See FIGURE 17A)	5	5	5 sections after exhaust heat exchanger tube is connected	Into exhaust heat exchanger tube
		"U" or "L" tube adjacent to the exhaust heat exchanger tube (See FIGURE 17B)	5	5	2 sections <i>before</i> "U" or "L" is connected 3 sections after exhaust heat exchanger tube is connected	Into end of straight tube before "U" or "L" Into exhaust heat exchanger tube
50 ft	100, 125, 150, 175, 200	Straight heat exchanger tube adjacent to the exhaust heat exchanger tube (See FIGURE 17A)	6	5	5 sections after exhaust heat exchanger tube is connected	Into exhaust heat exchanger tube
		"U" or "L" tube adjacent to the exhaust heat exchanger tube (See FIGURE 17B)	6	5	2 sections <i>before</i> "U" or "L" is connected 3 sections after exhaust heat exchanger tube is connected	Into end of straight tube before "U" or "L" Into exhaust heat exchanger tube
55 ft	125, 150, 175, 200	Straight heat exchanger tube adjacent to the exhaust heat exchanger tube (See FIGURE 17A)	6	5	All 5 sections after exhaust heat exchanger tube is connected	Into exhaust heat exchanger tube
		"U" or "L" tube adjacent to the exhaust heat exchanger tube (See FIGURE 17B)	6	5	2 sections <i>before</i> "U" or "L" is connected 3 sections after exhaust heat exchanger tube is connected	Into end of straight tube before "U" or "L" Into exhaust heat exchanger tube
60 ft	125, 150, 175, 200	Straight heat exchanger tube adjacent to the exhaust heat exchanger tube (See FIGURE 17A)	5	5	5 sections after exhaust heat exchanger tube is connected	Into exhaust heat exchanger tube
		"U" or "L" tube adjacent to the exhaust heat exchanger tube (See FIGURE 17B)	5	5	2 sections <i>before</i> "U" or "L" is connected 3 sections after exhaust heat exchanger tube is connected	Into end of straight tube before "U" or "L" Into exhaust heat exchanger tube
65 or 70 ft	175, 200	Straight heat exchanger tube adjacent to the exhaust heat exchanger tube (See FIGURE 17A)	5	5	5 sections after exhaust heat exchanger tube is connected	Into exhaust heat exchanger tube
		"U" or "L" tube adjacent to the exhaust heat exchanger tube (See FIGURE 17B)	5	5	2 sections <i>before</i> "U" or "L" is connected 3 sections after exhaust heat exchanger tube is connected	Into end of straight tube before "U" or "L" Into exhaust heat exchanger tube

## 6. Mechanical (cont'd)

### 6.2 Assemble and Suspend the Heater (cont'd)

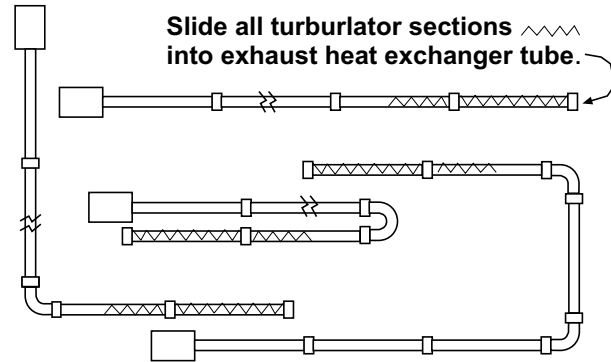
#### 6.2.3 Install the Heat Exchanger Tubes and Turbulator Strip Sections (cont'd)

##### Turbulator Requirements (cont'd)

**FIGURE 17A - Examples of configurations with the exhaust heat exchanger tube adjacent to a straight heat exchanger.**

**To install turbulator:**

- 1) Insert a turbulator section into the exhaust heat exchanger tube.
- 3) Interlock turbulator sections as they are inserted (See **FIGURE 16B**).
- 4) Continue until all required sections are in place.



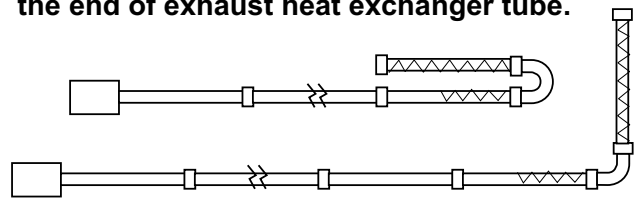
**FIGURE 17B - Examples of configurations that require more than three turbulator strips and have the exhaust heat exchanger tube adjacent to an "L" or U" heat exchanger tube.**

**To install turbulator:**

- 1) *Before* attaching the "U" or "L" tube, insert two interlocked turbulator sections (See **FIGURE 16B**) into the last straight tube.
- 2) Use compression couplings to attach the "U" or "L" heat exchanger tube to the straight tube and to the exhaust heat exchanger tube.
- 3) Insert three interlocked turbulator sections into the exhaust heat exchanger tube.

Slide two turbulator sections into heat exchanger tube before "U" or "L".

Slide three turbulator sections into the end of exhaust heat exchanger tube.



#### 6.2.4 Install Reflectors and Optional Side Shield and/or End Covers

##### Straight Tube Reflector Installation Instructions

**WARNING: Do not operate heater without reflectors. See Hazard Intensity Levels, page 2.**

Reflectors are shipped with the tubes. Clips and screws for length of system are included in the tube package hardware bag.

**FIGURE 18 - Reflector for Straight Tubes**



**CAUTION: Remove protective film before installing reflectors.**

**Parts/Tools Needed:** Clips and screws from the tube package hardware bag (see Paragraph 3), 1/8" drill, 5/16" nut driver

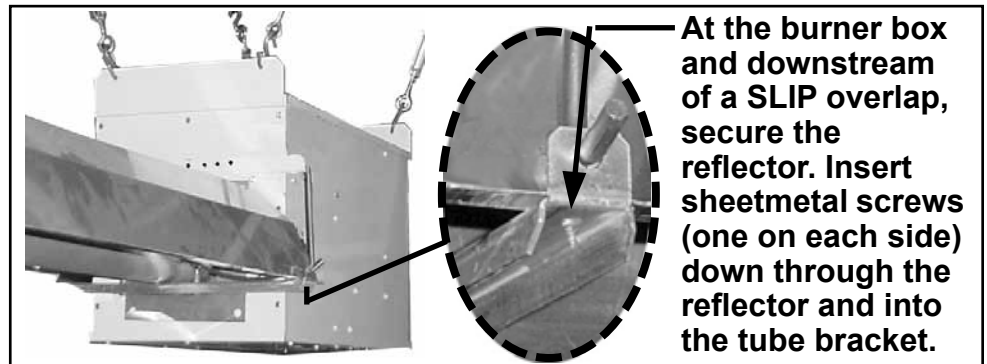
1. **Before installing reflectors, check a), b), c) and d).** If needed, adjust or add tube bracket or suspension point to comply with these requirements.
  - a) The combustion chamber tube must have two suspension points.
  - b) Each heat exchanger tube must have at least one suspension point.
  - c) There must be a suspension point within 12" (305mm) of every coupler.
  - d) All chains must be plumb with the suspension point.
2. **Before installing reflectors,** read the instructions to understand the difference between **NON-SLIP** and **SLIP** reflector overlaps. Installed reflectors **MUST** comply with the following.
  - **No more than two consecutive NON-SLIP overlaps on a straight system.**
  - **No more than four consecutive NON-SLIP overlaps in a section containing a single "U" or "L" tube reflector. NOTE: Two of the four**

**NON-SLIP** overlaps are required at each end of the “U” or “L” tube reflector.

- **No more than five consecutive NON-SLIP overlaps** in a section containing two “L” tube reflectors. **NOTE:** Four of the five overlaps are required at each end of the “L” tube reflectors.
  - **No consecutive SLIP overlaps.**
  - Straight system **MUST** comply with the installation illustrated in **FIGURE 19D** for the length of system being installed.
3. Begin reflector installation at the combustion chamber end. Remove the protective film. Slide the reflector into the wire reflector retainers on the combustion chamber tube. Position the reflector so that it is 1/4” (6mm) from the box.
  4. Attach the reflector to the tube bracket closest to the burner/control box (See **FIGURE 19A**). Reflector must be anchored at this end to keep it from moving due to expansion and contraction of the system.

**FIGURE 19A - Attach the Reflector to the First Tube Bracket and at SLIP Overlaps**

**CAUTION: Only screw reflector to the tube bracket at the burner box and at SLIP overlaps. Attaching reflectors at any other location will cause damage to the reflectors.**



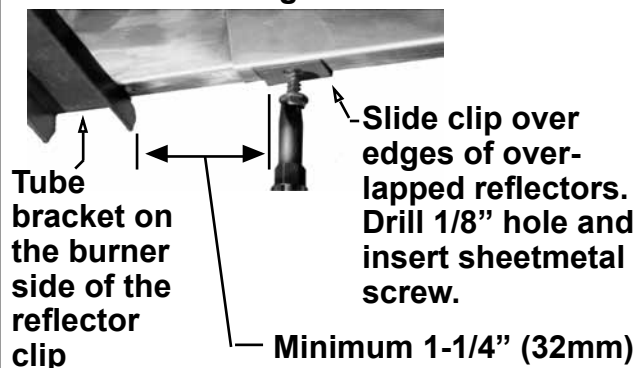
5. Remove the film from the next reflector and slide it into the wire reflector retainer on the adjacent straight heat exchanger tube. Position the reflector so that it overlaps the combustion chamber reflector by 1-1/2” (38mm).

**6. NON-SLIP Overlap (FIGURES 19B and 19C)**

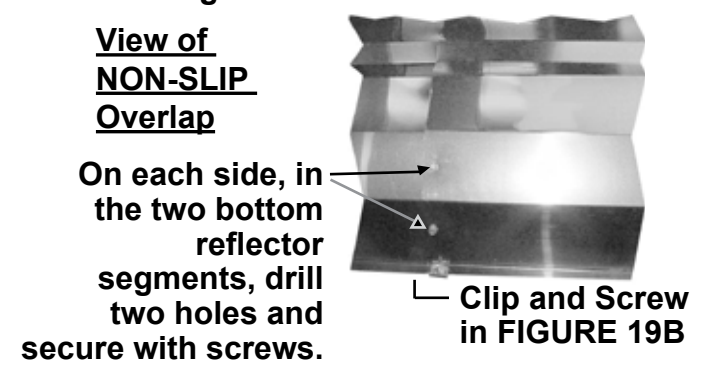
On each side where the two reflectors overlap, slide a clip over the two aluminum flanges (**FIGURE 19B**). To allow for reflector expansion, the clip must have a minimum of 1-1/4” (32mm) clearance from a tube bracket between the clip and the burner box. Position each clip, drill 1/8” hole, and insert screw.

Refer to **FIGURE 19C**. In the overlapped portion, on each side, drill a 1/8” hole in the two bottom reflector segments. Secure with sheetmetal screws.

**FIGURE 19B - NON-SLIP Overlap - Use Clips and Screws to Attach and Secure the Reflector Flanges**



**FIGURE 19C - On each side of the Overlapped Reflectors, Drill Two Holes in the Bottom Two Reflector Segments and Secure with Screws**



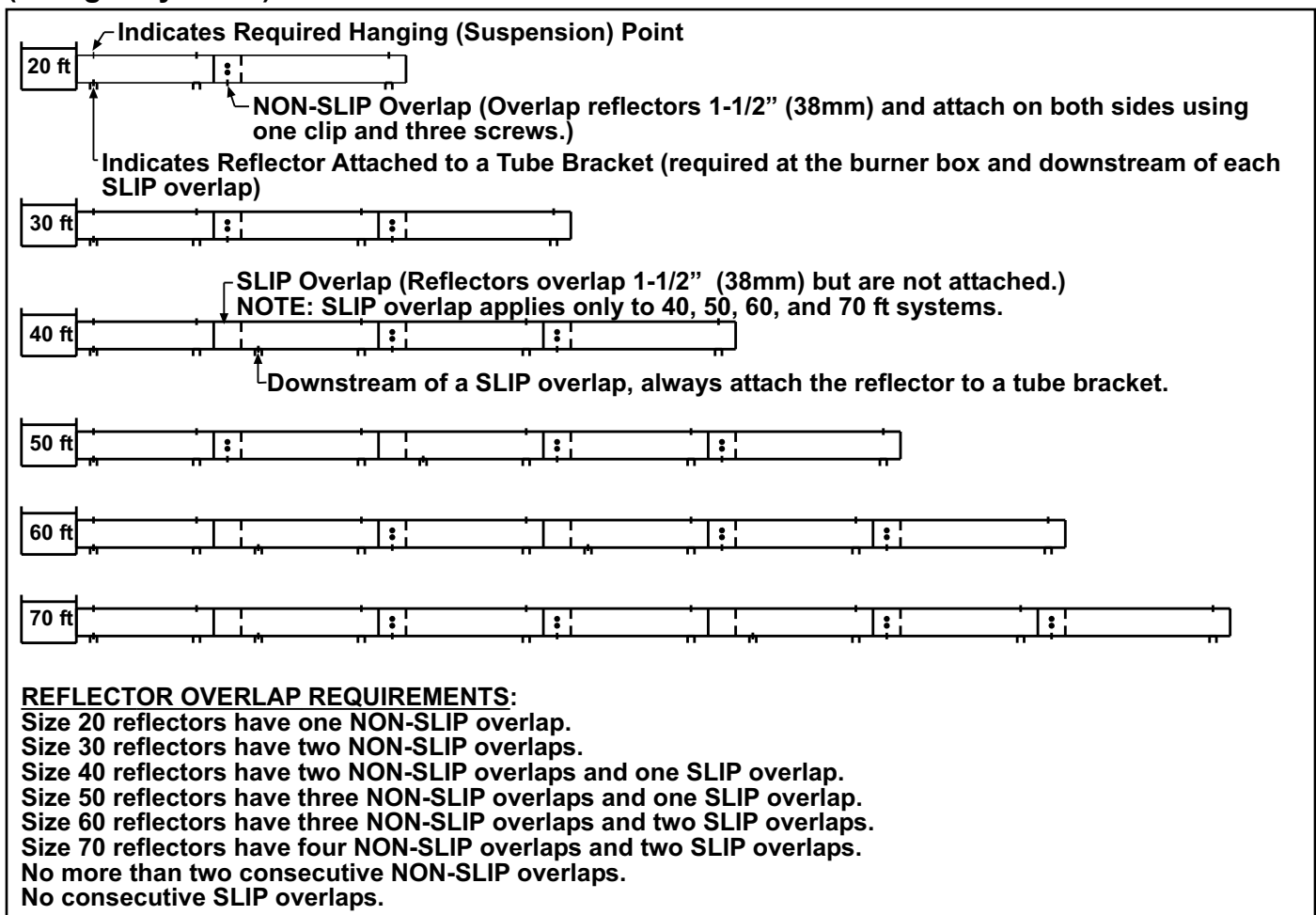
**NOTE: ALL reflector overlaps on 20 and 30 ft systems are NON-SLIP.**

## 6. Mechanical (cont'd)

### 6.2 Assemble and Suspend the Heater (cont'd)

#### 6.2.4 Install Reflectors and Optional Side Shield and/or End Covers (cont'd)

#### FIGURE 19D - Reflector Overlaps (Straight Systems)



#### "U" or "L" Tube Reflectors

## Straight Tube Reflector Installation Instructions (cont'd)

### 7. SLIP Overlap (One on 40 & 50 ft systems and two on 60 & 70 ft systems)

Install reflector with a 1-1/2" (38mm) overlap. **Do not screw the reflectors together.**

Immediately downstream of a **SLIP** overlap, install a reflector bracket, a U-bolt, and a reflector retainer. (**NOTE:** Suspension is not required.) Secure both sides of the reflector to the reflector bracket using the screws provided. Follow the procedure illustrated in **FIGURE 19A.**

### 8. Repeat **Step 5**, overlapping reflectors 1-1/2" (38mm) until the entire length of a straight system is covered, making **SLIP** or **NON-SLIP** overlaps as illustrated in **FIGURE 19D.**

If there are "U" or "L" tubes, install their reflector as you come to it before continuing with the straight reflectors. Follow the instructions packaged with the "U" or "L" tube.

#### Side Shields, Options CD13-22.

Follow the instructions in the "U" or "L" option package to assemble and install the reflector. A "U" tube system can be angled up to 45°. Reflectors on a system with an "L" tube cannot be angled.

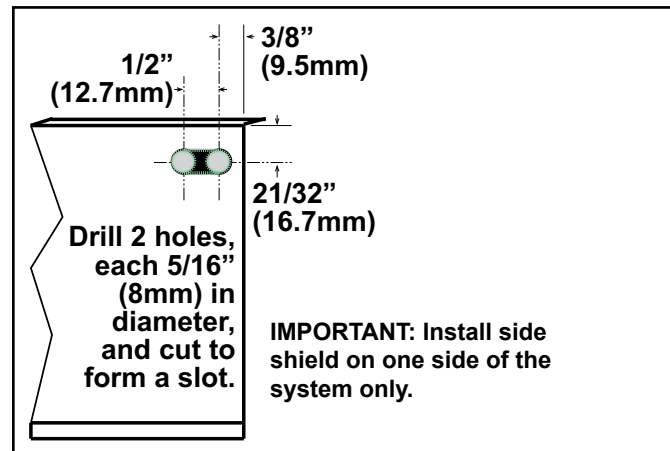
Optional side shields are 60-3/4" (1543mm) long pieces of reflector material that can be "hung" along one side of the heater. Each side shield section comes with an additional reflector retainer and tube bracket and two round clips. Side shield kits are designed to extend the full length of the system with a 3/4" (19mm) overlap, but may be adapted to fit the installation.

## Side Shield Installation Instructions

Because side shields can be installed anywhere along the tube length and use the same wire reflector retainers and tube brackets as the tubes, the side shield hanger slots must be made in the field to match the system. Therefore, the first hanger slot location is shown in **FIGURE 20**. After the first section is installed, determine the location of each hanger slot and drill and cut hanger slots one section at a time.

- 1) Side shields are designed with a 3/4" (19mm) overlap. On the first section, on the top edge with the 60° bend, measure in 3/8" (9.5mm) and 7/8" (22.2mm) from the end and 21/32" (16.7mm) from the bend. Drill two 5/16" (8mm) holes. Cut out the material between the two holes to form a slot. Repeat on the opposite end.

**FIGURE 20 - Drill 2 holes and cut a slot in each end of the first side shield section.**



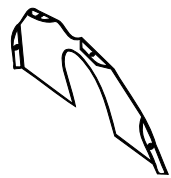
- 2) Starting at the already installed reflector retainer/bracket at the burner box (or wherever the side shield is being placed), determine where the next side shield hanger is needed. At that location, install one of the wire reflector retainers and a tube bracket supplied with the side shield. NOTE: Suspension is not required at any of the additional wire reflector retainers and tube brackets installed to support side shields.
- 3) Remove the protective film and hang the first side shield section from the ends of the two wire reflector retainers. To secure the side shield, slide the round clip over the ends of the wire until it contacts the side shield.
- 4) Repeat the process until all side shield sections are installed. To adapt to tube suspension points, a side shield may require more than two hanger slots.

## Reflector End Covers, Option CD27

The optional end covers are designed to “close” the vertical space on both the burner/control box end and the exhaust end of the reflector length.

Install following the illustrated instructions included in the option package.

**FIGURE 21 - Optional Reflector End Cover (one for each end)**



Reflectors may be angled up to 45°. Angling the reflector is accomplished by moving the position of the “S” hook on the hanger bar. The hanger bar has three holes left and right of the center hole. Moving the “S” hook to the first hole from center will rotate the reflector 15°; the second hole 30°; and the third hole 45°. Refer to **FIGURE 22** and comply with the requirements and instructions below.

- All reflectors in a system must be at the same angle.
- Reflectors on straight systems without a side shield may be angled 15°, 30°, or 45°; see **FIGURE 22**.

## 6. Mechanical (cont'd)

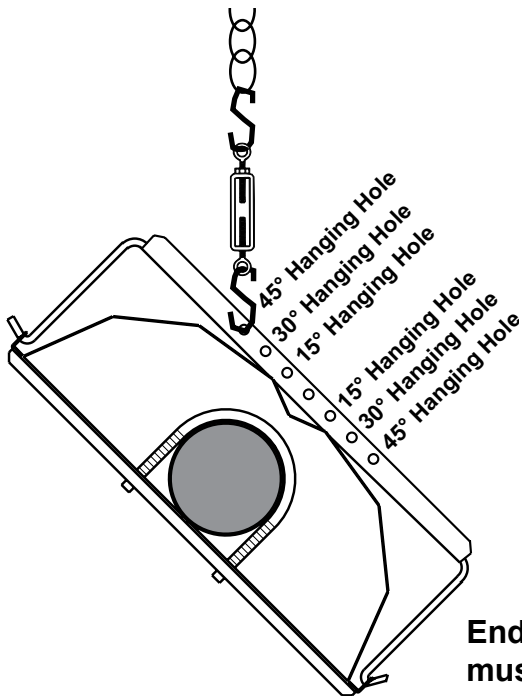
### 6.2 Assemble and Suspend the Heater (cont'd)

#### 6.2.4 Install Reflectors and Optional Side Shield and/or End Covers (cont'd)

- Reflectors on straight systems with a side shield may be angled 15° or 30°. The side shield must hang vertically.
- Reflectors on “U” systems without a side shield may be angled 15°, 30° or 45° or 15° or 30° with a side shield. Follow option installation instructions.
- If the system includes an “L” heat exchanger tube, the reflectors cannot be angled.

#### Angle Reflectors on Straight Systems or Angle “U” Configuration Systems

**FIGURE 22 - Adjust reflector angle by changing the location of the “S” hook on the hanger bar.**



#### Instructions for Angling Reflectors on a Straight System:

- 1) If the tube brackets are fastened tightly, loosen the nuts so that the “U” bolt will rotate with the wire retainer.
- 2) Move the “S” hook to another hole in the hanger bar. The first hole will angle the reflector 15°, the second 30°, and the third 45°. Adjust chain length as needed.
- 3) Verify that the end of the wire retainer on the lower side is the one with the sharper (45°) bend. If not, remove the retainer wire and reverse it.
- 4) Verify compliance with the requirements above. Tighten the nuts on all tube brackets.

#### 6.2.5 Recheck Couplings and Tube Brackets, Level the System, Check the Chains, and Close “S” Hooks

Verify that all couplings and tube brackets are tightened securely.

Tubes must be level. Use a spirit level and adjust the turnbuckles or chain links. Chains must be plumb with the suspension point.

Close all “S” hooks being careful not to change the chain length.

Straight systems should be straight; systems with “L” tubes should be at right angles; and “U” shaped systems should be parallel.

### 6.3 Gas Piping and Pressures

All piping must be in accordance with requirements outlined in the National Fuel Gas Code NFPA 54 / ANSI Z223.1 (latest edition) or CAN/CSA-B149.1 (latest edition). Gas supply piping installation should conform with good practice and with local codes.

Heaters for natural gas are orificed for operation with gas having a heating value of 1000 (± 50) BTU per cubic ft. If the gas at the installation does not meet this specification, consult the factory for proper orifice.

#### Gas Supply Pressure Table

BTUH Input	Gas Type	Supply Pressure	
		Minimum	Maximum
50,000 - 150,000	Natural	4.5” w.c.	14” w.c.
175,000 - 200,000	Natural	6” w.c.	14” w.c.
50,000 - 200,000	Propane	11” w.c.	14” w.c.

The gas supply must have sufficient pressure to supply the burner plus any other gas-fired appliances. Gas supply pressures required (measured with a manometer) are listed in the table on the left.

**WARNING: This appliance is equipped for a maximum gas supply pressure of 1/2 pound, 8 ounces, or 14 inches water column.**

**NOTE:** Supply pressure higher than 1/2 pound requires installation of an additional service regulator external to the unit.

**PRESSURE TESTING SUPPLY PIPING**

**Test Pressures Above 1/2 PSI:** Disconnect the heater and manual valve from the gas supply line which is to be tested. Cap or plug the supply line.

**Test Pressures Below 1/2 PSI:** Before testing, close the manual valve on the heater.

**Sizing Gas Supply Lines**

Capacity of Piping												
Cubic Feet per Hour based on 0.3" w.c. Pressure Drop												
Specific Gravity for Natural Gas -- 0.6 (Natural Gas -- 1000 BTU/Cubic Ft)												
Specific Gravity for Propane Gas -- 1.6 (Propane Gas -- 2550 BTU/Cubic Ft)												
Length of Pipe	Diameter of Pipe											
	1/2"		3/4"		1"		1-1/4"		1-1/2"		2"	
	Natural	Propane	Natural	Propane	Natural	Propane	Natural	Propane	Natural	Propane	Natural	Propane
20'	92	56	190	116	350	214	730	445	1100	671	2100	1281
30'	73	45	152	93	285	174	590	360	890	543	1650	1007
40'	63	38	130	79	245	149	500	305	760	464	1450	885
50'	56	34	115	70	215	131	440	268	670	409	1270	775
60'	50	31	105	64	195	119	400	244	610	372	1105	674
70'	46	28	96	59	180	110	370	226	560	342	1050	641
80'	43	26	90	55	170	104	350	214	530	323	990	604
90'	40	24	84	51	160	98	320	195	490	299	930	567
100'	38	23	79	48	150	92	305	186	460	281	870	531
125'	34	21	72	44	130	79	275	168	410	250	780	476
150'	31	19	64	39	120	73	250	153	380	232	710	433
175'	28	17	59	36	110	67	225	137	350	214	650	397
200'	26	16	55	34	100	61	210	128	320	195	610	372

Note: When sizing supply lines, consider possibilities of future expansion and increased requirements.  
Refer to National Fuel Gas Code for additional information on line sizing.

**DANGER: Do not install gas piping where it may be exposed to radiant or convection heat. See Hazard Levels, page 2.**

**Gas Connection Requirements**

Since the tubular heater does expand and contract, the connection between the supply line and the heater must allow for expansion and contraction. Use only an agency certified, stainless steel connector with a length of 36" (9140mm) and a minimum size of 3/4" I.D.

**Canadian Installation NOTE:** The Natural Gas and Propane Installation Code, CAN/CSA B149.1, requires a Type I hose connector certified to CAN/CGA-8.1 with a length of 36 (±6) inches / 90 (±15) cm. Type I hose is field supplied when required.

**In the United States,** if a 36" stainless flexible connector, Option CE4, was ordered with the heater, it will be shipped separately. Pressure drops for Option CE4 stainless flexible connector are listed in the table below.

A shutoff valve and a drip leg or sediment trap must be provided in the gas supply line at each heater. See **FIGURE 23**, page 22.

**WARNING: Strong cleaning solutions or chemical substances must not come in contact with the flexible connector.**

Pressure Drop (Inches W.C.)	
BTUH Input	Option CE4, 3/4" I.D.
50,000	0.05
75,000	0.05
100,000	0.10
125,000	0.15
150,000	0.20
175,000	0.40
200,000	0.50

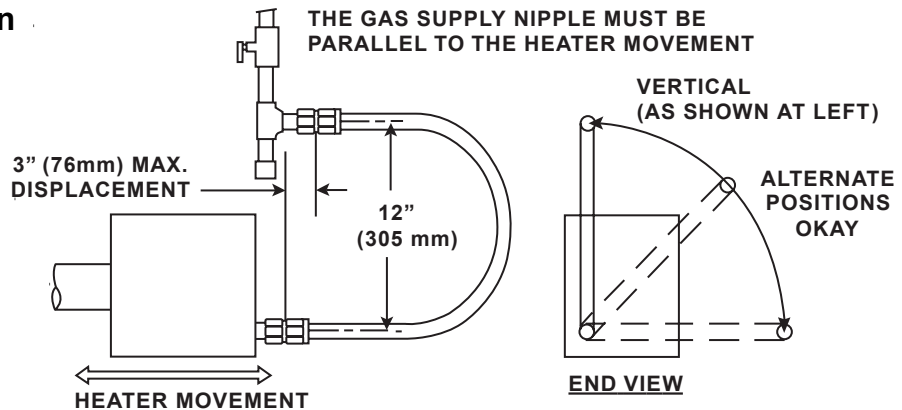
## 6. Mechanical (cont'd)

### 6.3 Gas Piping and Pressures (cont'd)

Use a joint compound that is resistant to propane gas at all connections.  
Test all gas lines using a leak-detecting solution.

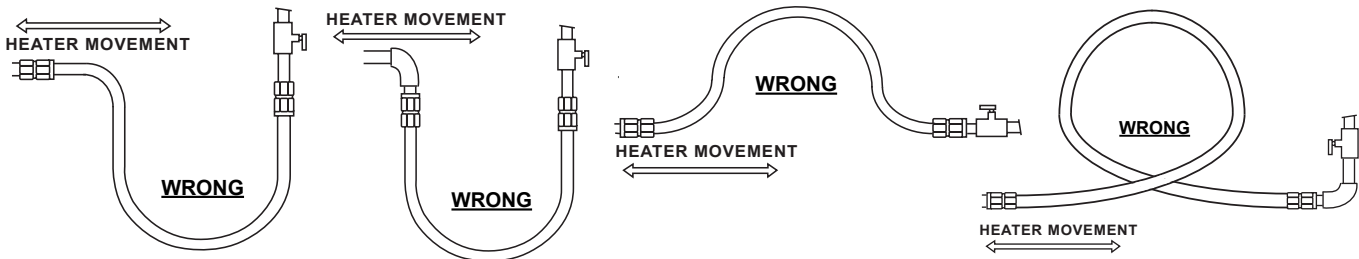
**FIGURE 23 - Gas Connection  
Installation Requirements**

**CORRECT  
POSITIONS**



**WARNING: CONNECTOR MUST BE INSTALLED IN "D" CONFIGURATION. Use a 36" (914mm) long connector of 3/4" nominal ID with this heater.**

### **INCORRECT POSITIONS**



**WARNING: All components of the gas supply system must be leak-tested prior to placing equipment in service. NEVER TEST FOR LEAKS WITH AN OPEN FLAME. See Hazard Levels, page 2.**

### Gas Valve Outlet Pressure Settings

Valve Outlet Pressure Settings		
BTUH Input	Gas Type	Outlet Pressure
50,000 - 150,000	Natural	3.5" w.c.
175,000 - 200,000	Natural	5" w.c.
50,000 - 200,000	Propane	10" w.c.

Measuring valve outlet gas pressure cannot be done until the heater is in operation. It is included in the steps of the "Check-Test-Start" procedure in Paragraph 8. The following warnings and instructions apply.

Before attempting to measure or adjust the valve outlet gas pressure, the inlet (supply) pressure must be within the specified range for the gas being used both when the heater is in operation and on standby. Incorrect inlet pressure could cause excessive outlet gas pressure immediately or at some future time.

#### **Instructions for Checking Valve Outlet Pressure:**

1) With the manual valve (on the combination valve) positioned to prevent flow to the main burners, connect a manometer to the 1/8" pipe outlet pressure tap in the valve. **NOTE:** A manometer (fluid-filled gauge) is recommended rather than a spring type gauge due to the difficulty of maintaining calibration of a spring type gauge.

2) Open the valve and operate the heater. Measure the outlet gas pressure. Adjustment to the factory preset regulator is rarely necessary.

But if adjustment is required, set pressure to correct settings by turning the regulator screw IN (clockwise) to increase pressure. Turn regulator screw OUT (counterclockwise) to decrease pressure.

Remove manometer, replace the cap, and check for leak at pressure tap.

**CAUTION: DO NOT bottom out the gas valve regulator adjusting screw. This can result in unregulated manifold pressure causing excess overfire and heat exchanger failure.**

**Instructions for High Altitude Derate Derate is by Valve Outlet Pressure Adjustment for High Altitude Operation**

**This adjustment can only be done after the heater is in operation. It is included in the startup procedures.**

NOTE: Sizes 50-175 - If elevation is above 6000 ft (1830M), a high altitude pressure switch should have been installed; see Paragraph 6.1.

1. Determine the required valve outlet pressure for the elevation where the heater will be operating. If unsure of the elevation, contact the local gas supplier.

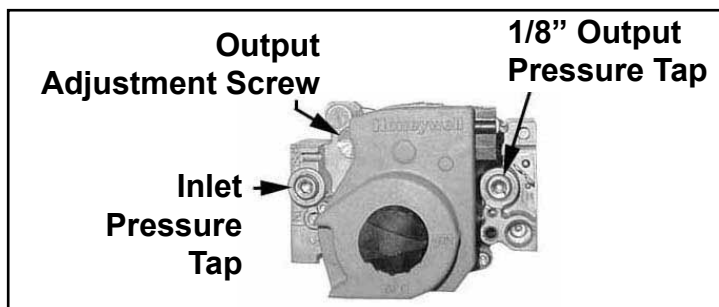
<b>Manifold Pressure Settings by Altitude for the United States</b>				
Altitude		Natural Gas (" w.c.)		Propane (" w.c.)
Feet	Meters	50, 75, 100, 125, 150	175 & 200	50, 75, 100, 125, 150, 175, 200
0 - 2000	0 - 610	3.5	5.0	10.0
2001 - 3000	611 - 915	2.7	3.9	7.7
3001 - 4000	916 - 1220	2.5	3.5	7.1
4001 - 5000	1221 - 1525	2.2	3.2	6.4
5001 - 6000	1526 - 1830	2.0	2.9	5.8
6001 - 7000	1831 - 2135	1.8	2.6	5.2
7001 - 8000	2136 - 2440	1.6	2.3	4.6
8001 - 9000	2441 - 2745	1.4	2.0	4.1
9001 - 10000	2746 - 3051	1.3	1.8	3.6

<b>Manifold Pressure Settings by Altitude for Canada</b>				
Altitude		Natural Gas (" w.c.)		Propane (" w.c.)
Feet	Meters	50, 75, 100, 125, 150	175 & 200	50, 75, 100, 125, 150, 175, 200
0 - 2000	0 - 610	3.5	5.0	10.0
2001 - 4500	611 - 1373	2.8	4.1	8.1

2. Locate the 1/8" output pressure tap on the valve (See **FIGURE 24**). Turn the knob on the valve to "OFF". Connect a manometer to the 1/8" pipe outlet pressure tap in the valve. Use a water column manometer that is readable to the nearest tenth of an inch.

**FIGURE 24 - Gas Valve showing Outlet Pressure Tap and Adjustment Locations**



3. Turn the knob on the valve to "ON". Remove the cap from the pressure adjusting screw and adjust the gas train pressure to the pressure selected from the table above. Adjust pressure by turning the regulator screw IN (clockwise) to increase pressure or OUT (counterclockwise) to decrease pressure.
4. Turn up the thermostat. Cycle the burner once or twice to properly seat the adjustment spring in the valve. Re-check the pressure(s). When the outlet pressure is right for the installation, remove the manometer and replace the cap. Check for leak at the pressure tap fitting.
5. With the heater operating, determine that the inlet pressure to the valve for natural gas is between 4.5" and 14" w.c. for Sizes 50-175 and 175-200.

## 6. Mechanical (cont'd)

### 6.3 Gas Piping and Pressures (cont'd)

and 14" w.c. for Sizes 175-200. For propane gas, the inlet pressure must be between 11" and 14" w.c. Take this reading as close as possible to the heater (Heaters are equipped with gas valves that have an inlet pressure tap.) If the inlet pressure is not within the specified range, the inlet pressure must be corrected and Steps 3 and 4 repeated.

- Find the High Altitude Adjustment label in the plastic bag that contained these instructions. Using a permanent marker, fill-in the appropriate information from the tables below. Select a position for the label on the rear of the burner/control box adjacent to the rating plate. Be sure the surface is clean and dry and adhere the label.

### BTUH Inputs by Altitude

BTUH Inputs by Altitude in the United States								
ALTITUDE		NORMAL INPUT						
Feet	Meters	Size 50	Size 75	Size 100	Size 125	Size 150	Size 175	Size 200
0 - 2000	0 - 610	50000	75000	100000	125000	150000	175000	200000
2001 - 3000	611 - 915	44000	66000	88000	110000	132000	154000	176000
3001 - 4000	916 - 1220	42000	63000	84000	105000	126000	147000	168000
4001 - 5000	1221 - 1525	40000	60000	80000	100000	120000	140000	160000
5001 - 6000	1526 - 1830	38000	57000	76000	95000	114000	133000	152000
6001 - 7000	1831 - 2135	36000	54000	72000	90000	108000	126000	144000
7001 - 8000	2136 - 2440	34000	51000	68000	85000	102000	119000	136000
8001 - 9000	2441 - 2745	32000	48000	64000	80000	96000	112000	128000
9001 - 10000	2746 - 3051	30000	45000	60000	75000	90000	105000	120000

BTUH Inputs by Altitude in Canada								
ALTITUDE		NORMAL INPUT						
Feet	Meters	Size 50	Size 75	Size 100	Size 125	Size 150	Size 175	Size 200
0 - 2000	0 - 610	50000	75000	100000	125000	150000	175000	200000
2001 - 4500	611 - 1373	45000	67500	90000	112500	135000	157500	180000

### 6.4 Venting and Combustion Air

Venting must be in accordance with the National Fuel Gas Code NFPA 54/ANSI Z223.1 (latest edition) or CAN/CSA B149.1 (latest edition), and all local codes.

The ANSI standard applicable to this heater does not require venting categorization. If such a requirement existed, this heater would be in Category III. (Category III appliances have a positive-pressure vent requiring a gas tight sealed vent system.) These tubular infrared heaters have been designed to operate safely and efficiently with vent pipe lengths shown in the Vent Length Table below. Vent systems may either be vertical or horizontal. The type of vent required depends on the size of heater and the vent run configuration.

#### Vent Category Table

#### Type of Vent Required by Vent Category

Model Sizes	50, 75, 100, 125	150, 175, 200
-- with a Horizontal Vent Run	Category III	Category III
-- with a Vent Run that is at least 1/2 vertical (using equivalent lengths from the Vent Length Table below)	Category I or Category III	Category III
-- with a Dual Vent Adapter, Option CC5	Category III	Category III

Vent terminal end may be either single-wall pipe or double-wall pipe. A vent terminal cap is required. Dual venting of two units is permissible when using an Optional Dual Vent Kit (Option CC5). Comply with the specific requirements and instructions in the following paragraphs.

#### 6.4.1 Specific Venting Requirements

**1. Vent Pipe Length** - The vent lengths shown in the Vent Length Table are based on (1) the maximum permissible resistance to flow at which each model size will operate and (2) the potential for continuous condensing. Condensing in the vent pipe should not occur after equilibrium has been reached when the

surrounding ambient temperature is 60°F unless otherwise noted (See Vent Requirement No. 6, Condensation).

Do not exceed maximum vent length. Minimum vent length is 5 feet (1.5M).

## Vent Length Table

Vent Length Table for Tubular Infrared Heaters												
Input Size (000)	Straight Tube Length (ft)	Vent Diameter (inches)	Vent Length				Equivalent Length for					
			feet		M		Elbow				Dual Vent Adapter Box*	
			Max	Min	Max	Min	90°		45°		ft	M
50	20, 25, 30, 35, 40	4	20	5	6.1	1.5	3	0.9	1-1/2	0.5	3	0.9
75	20, 25	4	45	5	13.7	1.5	6	1.8	3	0.9	6	1.8
	30, 35		35	5	10.7	1.5	5	1.5	2-1/2	0.8	5	1.5
	40		20	5	6.1	1.5	3	0.9	1-1/2	0.5	3	0.9
100	30, 35	4	45	5	13.7	1.5	6	1.8	3	0.9	6	1.8
	40, 45		35	5	10.7	1.5	5	1.5	2-1/2	0.8	5	1.5
	50		20	5	6.1	1.5	3	0.9	1-1/2	0.5	3	0.9
125	30, 35, 40, 45, 50, 55, 60	4	60	5	18.3	1.5	12	3.7	6	1.8	12	3.7
150	40, 45, 50, 55, 60	4	60	5	18.3	1.5	12	3.7	6	1.8	12	3.7
175	40, 45, 50, 55, 60, 65, 70	4	60	5	18.3	1.5	12	3.7	6	1.8	12	3.7
200	50, 55, 60, 65, 70	4	60	5	18.3	1.5	12	3.7	6	1.8	12	3.7

\*Must be deducted from the total vent length of **each** heater.

**NOTE:** Use equivalents listed when calculating for elbows and optional dual vent adapter box (Option CC5).

**2. Vent Pipe Type** - Use only 4-inch diameter vent pipe.

**If the type of vent required is Category III** (refer to Vent Category Table, page 24), use either a vent pipe approved for a Category III heater or appropriately sealed 26-gauge galvanized steel or equivalent single-wall pipe.

**If the type of vent required is Category I** (refer to Vent Category Table, page 24), unsealed 26-gauge galvanized steel or equivalent single-wall pipe or double-wall (Type B) vent pipe may be used.

**3. Vent Pipe Joints** - Vent system joints depend on the vent category and the type of pipe being used.

**If installed as a Category III appliance and using single-wall vent pipe**, join pipes with at least two non-corrosive screws per vent pipe joint and **seal all joints** to prevent leakage of flue gases into the building. For sealing joints, aluminum tape suitable for 550°F (required in California) or silicone sealant is recommended. Vent tape is available from the heater manufacturer as P/N 98266.

**If installed as a Category III appliance and using vent pipe specifically approved for Category III vent systems**, follow the pipe manufacturer's instructions for proper sealing. (**NOTE:** Single-wall pipe must be used to connect to the exhaust heat exchanger tube.)

**If installed as a Category I appliance (allowed only for Sizes 50-125 when at least 1/2 of the total equivalent length of the vent system is vertical)**, use at least two non-corrosive screws per vent pipe joint on single-wall pipe or follow the pipe manufacturer's instructions for joining double-wall pipe. When attaching double-wall pipe to single-wall pipe or the vent cap, follow the instructions in the Addendum Section, page 45. (**NOTE:** Single-wall pipe must be used to connect to the exhaust heat exchanger tube.)

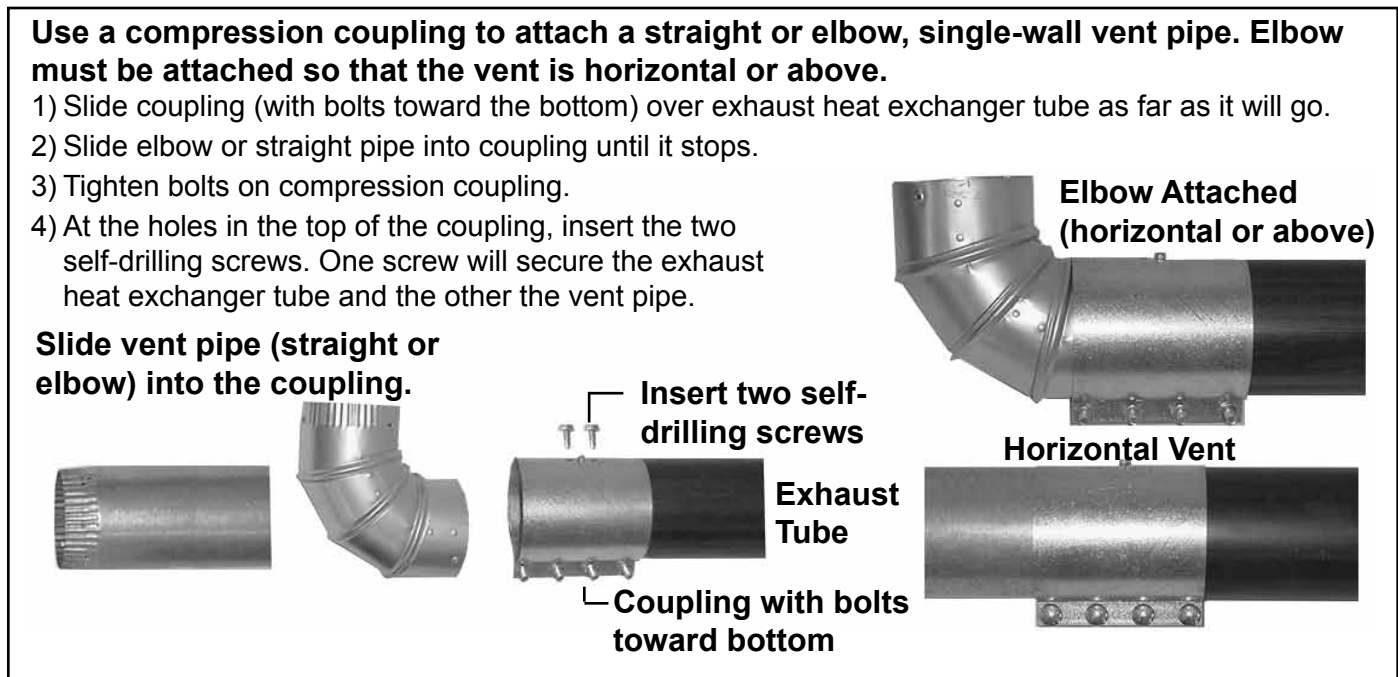
**4. Attach Vent Pipe to Heater (FIGURE 25)** - Use a compression coupling to attach the vent pipe to the exhaust heat exchanger tube.

## 6. Mechanical (cont'd)

### 6.4 Venting and Combustion Air (cont'd)

#### 6.4.1 Specific Venting Requirements (cont'd)

**FIGURE 25 - Attach Single-Wall Metal Vent Pipe to Exhaust Heat Exchanger Tube**



**5. Vent System Support** - Vent pipe support is especially important with the tubular infrared system because of the added stress which may be caused by expansion and contraction of the overall system. Support lateral runs a minimum of every six feet (1.8M) using non-combustible material, such as steel strap or chain. Do not rely on the heater for support of either horizontal or vertical vent pipe.

**6. Condensation** - If single-wall vent pipe is exposed to cold air or run through unheated areas, it must be insulated. Where extreme conditions are anticipated, install a means of condensate disposal.

**7. Vent Terminal and Vent Cap** - The vent terminal and vent cap must be the same diameter as the vent run. Terminate the vent system with a Reznor Option CC1 vent cap. A different style vent cap could cause nuisance problems and/or unsafe conditions.

See the illustrations in **FIGURES 26 and 27** for requirements of both vertical and horizontal vent termination. Using either single or double wall vent terminals is illustrated. Many local codes require the use of double-wall (Type B) vent for the portion of vent pipe (terminal) on the outside of the building.

If double-wall pipe is used in the vent terminal, follow the instructions in the Addendum, page 45, to attach the vent cap and to connect the double-wall pipe to the single-wall vent pipe.

**NOTE:** For optional vent terminal installations, see dual vent terminal option, Paragraph 6.4.2 or unvented installation in Paragraph 6.4.3.

### Horizontal Vent and Inlet Air Terminals

**Air Inlet Terminal Clearance** - The bottom of the air inlet terminal shall be located not less than one foot (305mm) above grade and at least 6 inches (152mm) above anticipated snow depth.

**Vent Terminal** - A vent cap is required. Maintain a clearance of 18 inches (457mm) from the wall to the vent terminal cap for stability under wind conditions.

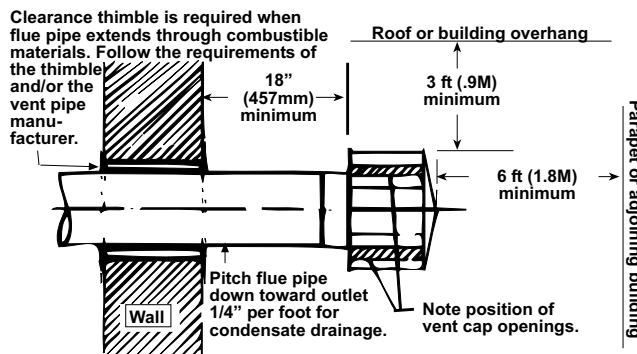
Products of combustion can cause discoloration of some building finishes and deterioration of masonry materials. Applying a clear silicone sealant that is normally used to protect concrete driveways can protect masonry materials. If discoloration is an esthetic problem, relocate the vent or install a vertical vent.

### Horizontal Vent Clearance Table

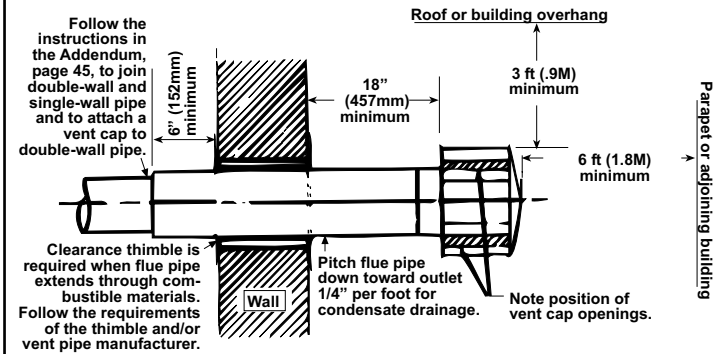
Structure	Minimum Clearances for Vent Termination Location (all directions unless specified)
Forced air inlet within 10 ft (3.1m)	3 ft (0.9M) above*
Combustion air inlet of another appliance	6 ft (1.8M)
Door, window or gravity air inlet (any building opening)	4 ft (1.2M) horizontally; 4 ft (1.2M) below; 1 ft (305mm) above
Electric meter, gas meter **, and relief equipment	U.S. - 4 ft (1.2M) horizontally; Canada - 6 ft (1.8M) horizontally
Gas regulator **	U.S. - 3 ft (0.9M); Canada - 6 ft (1.8M)
Adjoining building or parapet	6 ft (1.8M)
Adjacent public walkways	7 ft (2.1M) above
Grade (ground level)	1 ft (305mm) above
*This heater is approved for installation as illustrated in <b>FIGURE 26B</b> .	
**Do not terminate the vent directly above a gas meter or service regulator.	
The vent must be at least 6" (152mm) higher than anticipated snow depth.	

**FIGURE 26A - Horizontal Vent Terminal Arrangements** (drawings are not proportional; read all information)

#### SINGLE WALL - Single wall vent run and single wall terminal end

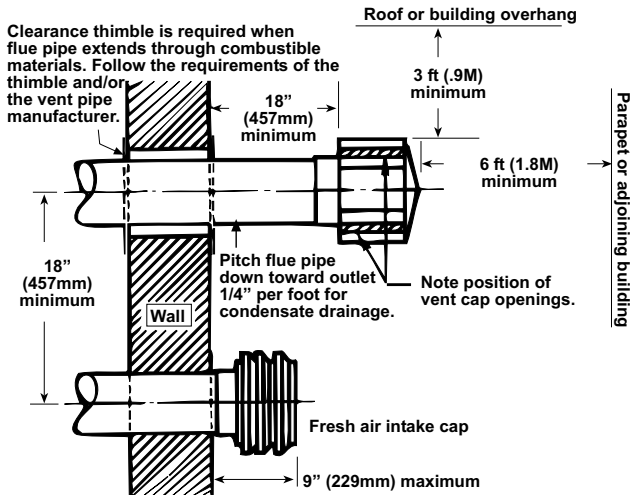


#### DOUBLE WALL - Single wall vent run and double wall terminal end

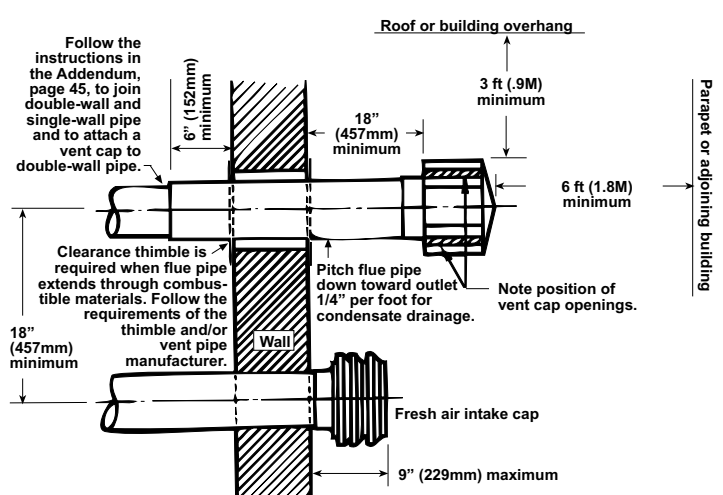


**FIGURE 26B - Horizontal Vent Terminal/Air Intake Arrangements** (drawings are not proportional; read all information)

#### SINGLE WALL - Single-wall vent run; single-wall terminal end; and single-wall fresh air intake



#### DOUBLE WALL - Single-wall vent run; double-wall terminal end; and single wall fresh air intake



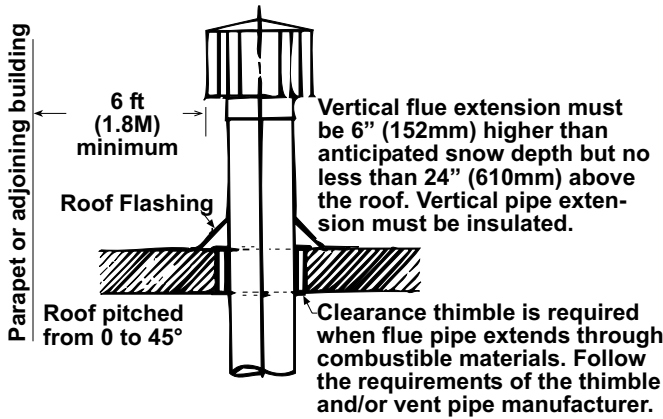
**6. Mechanical  
(cont'd)**

**6.4 Venting and Combustion Air (cont'd)  
6.4.1 Specific Venting Requirements (cont'd)**

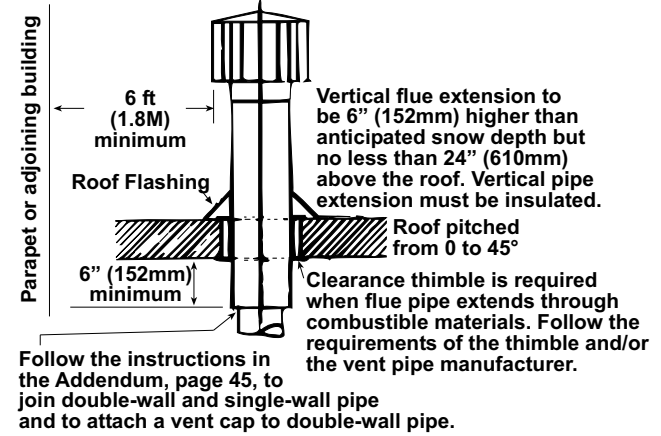
**Vertical Vent and Inlet Air Terminals**

**FIGURE 27A - Vertical Vent Terminal Arrangements** (drawings are not proportional; read all information)

**SINGLE WALL - Single wall vent run and single wall terminal end**

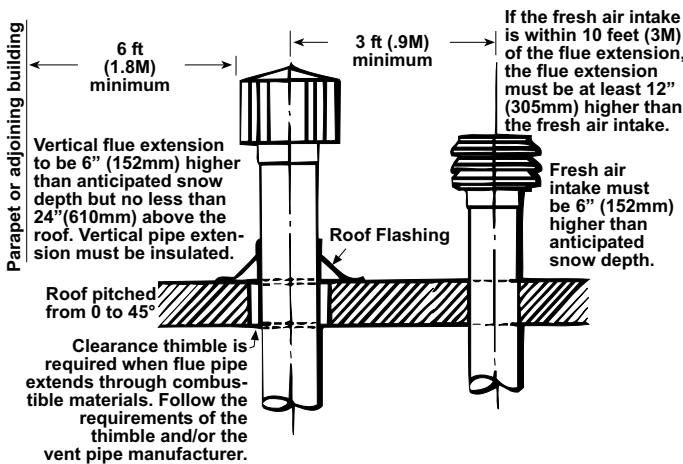


**DOUBLE WALL - Single wall vent run and double wall terminal end**

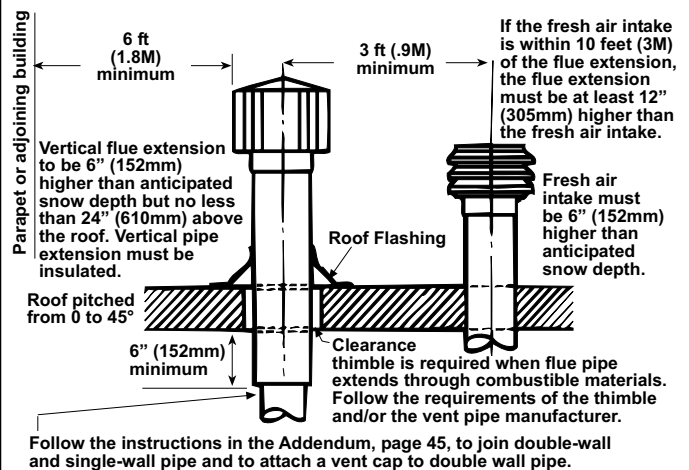


**FIGURE 27B - Vertical Vent Terminal/Air Intake Arrangements** (drawings are not proportional; read all information)

**SINGLE WALL - Single-wall vent run; single-wall terminal end; and single-wall fresh air intake**



**DOUBLE WALL - Single-wall vent run; double-wall terminal end; and single-wall fresh air intake**



**6.4.2 Dual Vent Terminal, Option CC5**

**Dual Vent Terminal Kit**

**Dual Venting** - By using the Dual Vent Option Kit, Option CC5, two heaters may use the same vent terminal. No other dual venting arrangement is approved.

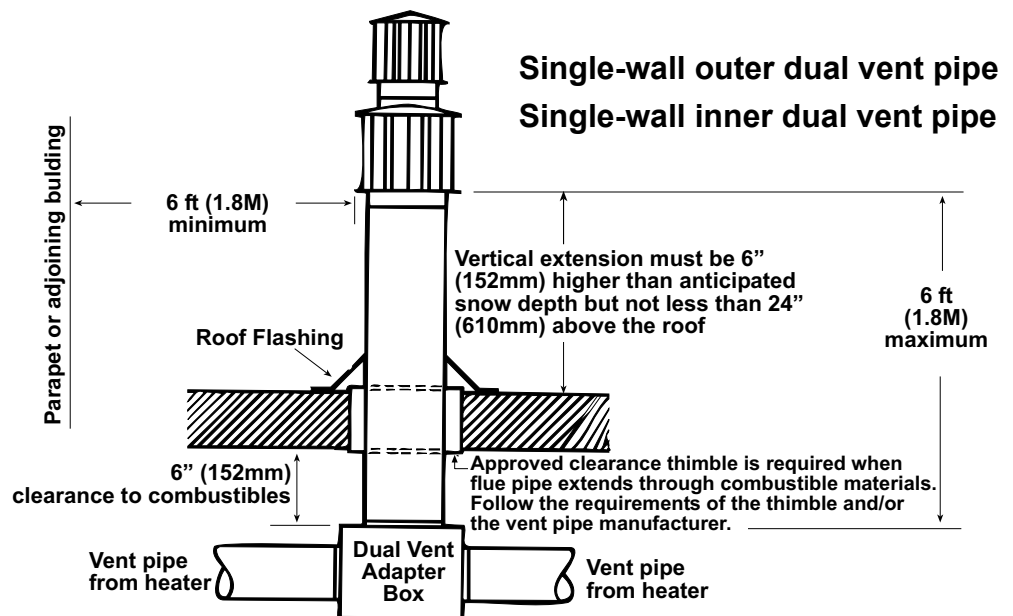
Follow the installation instructions and requirements included in the Option Kit. See Vent Terminal Arrangements in **FIGURES 28A and 28B**.



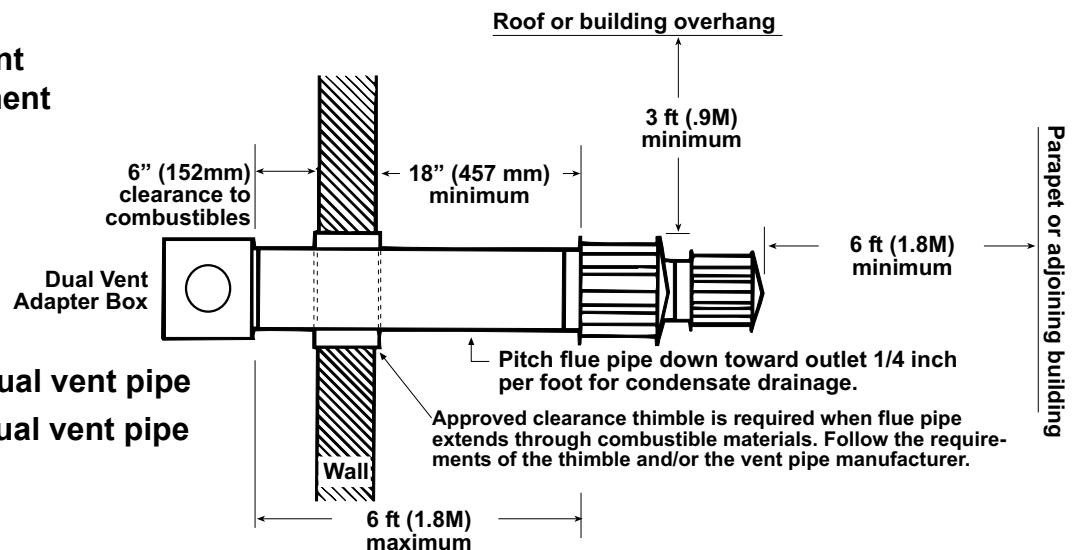
**WARNING:** Dual venting of two heaters is permitted only when using the Dual Vent Kit, Option CC5. (Refer to **FIGURES 28A and 28B**.) No other manifolding of vent runs is permitted due to possible back pressure and recirculation of combustion products into the building. See Hazard Levels, page 2.

## Dual Vent Terminal Arrangements with Option CC5

**FIGURE 28A -  
Vertical Dual  
Vent Terminal  
Arrangement**

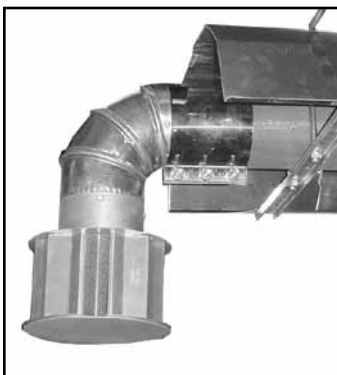


**FIGURE 28B -  
Horizontal Dual Vent  
Terminal Arrangement**



### 6.4.3 Unvented Installation

**FIGURE 29 - Install  
"Inverted" Terminal  
Cap on an Unvented  
Heater**



Model VR/GVR heaters are approved for operation without an outdoor vent. Before installing a tubular infrared heater in the unvented mode, extreme care should be exercised in examining the building atmosphere and structure.

**Where an unvented infrared heater is used, natural or mechanical means shall be provided to supply and exhaust at least 4 cfm for natural gas and 5 cfm for propane gas, per hour input of installed heaters.**

Exhaust openings for removing flue products shall be above the level of the heater.

When mechanical means is provided to supply and exhaust, a positive interlock must be provided by the installer so that the heater cannot operate unless the supply and exhaust system is operating.

- **Do not** operate in the unvented mode when dust or dirt are present.
- **Do not** operate in the unvented mode in a building where contaminants are in the air that will produce a toxic gas when burned or exposed to high temperatures.

**NOTE:** If either of the above situations exist, it is recommended that a vented system with an optional combustion air inlet be installed.

**6. Mechanical  
(cont'd)  
6.4 Venting and  
Combustion Air  
(cont'd)**

**6.4.3 Unvented Installation (cont'd)**

**DANGER: The fresh air requirement of 4 CFM per 1000 BTUH for natural gas and 5 CFM per 1000 BTUH for propane gas is mandatory when operating a heater in the unvented mode. See Hazard Levels, page 2.**

- **Do not** operate in the unvented mode if there is any doubt about the quality of the insulation in the building. Unvented operation in a building that has an uninsulated roof or that may have uninsulated structural members partially exposed to the outdoors may result in condensation. The condensation may be severe enough to drip and/or cause corrosion.
- **Do not** install in the unvented mode with outside combustion air unless the inlet air cap is at or below the plane of the heater.

When installing a heater in the unvented mode, a vent cap must be used and must be inverted as illustrated in **FIGURE 29**. Install the elbow as shown in **FIGURE 25** but in addition to securing the elbow with one screw on the top, secure it to the compression coupling using two additional non-corrosive sheetmetal screws with all three screws spaced approximately 120° apart. Attach the vent cap to the 90° elbow in the same manner with three sheetmetal screws.

When a heater is operated without being vented to the outdoors, the **TOP clearance to combustibles is 18" (457mm); see Paragraph 4.3.**

**6.4.4 Combustion Air**

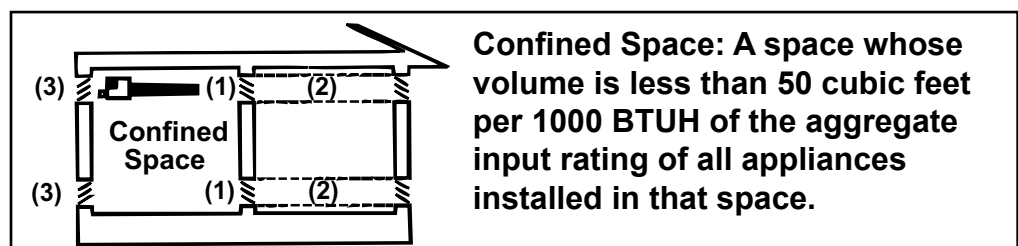
The burner is equipped with a centrifugal blower to provide combustion air. The air for combustion can come either from the heated space or be piped directly from the outside. Combustion air should be piped from the outside if (1) the pressure in the building is negative, (2) the atmosphere is dirt laden, (3) the atmosphere contains any substance that will cause toxic gas when passed through a flame, or (4) the heater is installed in a tightly closed room that does not provide required air for combustion.

**If drawing combustion air from the heated space**, the screened combustion air opening on the burner box must be kept clean. Maintain a minimum 12" clearance from the combustion air inlet opening. If the heater is located in a tightly closed room and is not equipped with a combustion air inlet pipe, provision must be made to supply air for combustion to the room.

The requirements for combustion and ventilation air depend upon whether the unit is located in a confined or unconfined space. An "unconfined" space is defined as a space whose volume is not less than 50 cubic feet per 1000 BTUH of the aggregate input rating of all appliances installed in that space. Under all conditions, enough air must be provided to ensure there will not be a negative pressure condition within the equipment room or space.

Do not install a unit in a confined space without providing wall openings leading to and from this space. Provide adequate openings near floor and ceiling for ventilation and air for combustion, as shown in **FIGURE 30**, depending on combustion air source as noted below.

**FIGURE 30 -  
Combustion Air  
and Ventilation  
Requirements for a  
Confined Space**



Add total BTUH of all appliances in the confined space and divide by figures below for square inch free area size of each (top and bottom) opening.

1. **Air from inside building** -- openings 1 square inch free area per 1000 BTUH. Never less than 100 square inches free area for each opening. See (1) in **FIGURE 30**.
2. **Air from outside through duct** -- openings 1 square inch free area per 2000 BTUH. See (2) in **FIGURE 30**.
3. **Air direct from outside** -- openings 1 square inch free area per 4000 BTUH. See (3) in **FIGURE 30**.

NOTE: For further details on supplying combustion air to confined space, see National Fuel Gas Code Z223.1 (latest edition).

### Combustion Air Inlet Kit, Option DE2



### Outside Combustion Air Pipe Length Table

If **directly piped outside combustion air is required**, use optional inlet air kit, Option DE2. Follow the instructions included with the kit. The inlet air pipe should be of a noncorroding material. The maximum length of the inlet air pipe must not exceed the length shown in the Table below.

If the inlet air pipe passes through moisture-laden air, insulation or double-wall tubing may be needed to prevent condensation on the outside of the pipe. Use the combustion air inlet cap supplied with the option kit. A different type of combustion air inlet cap could cause nuisance problems and/or unsafe operating conditions.

Maximum Length of Outside Combustion Air Inlet Pipe					
Type of Inlet Air Pipe	BTUH Size	Hz	Maximum Length	Equivalent Length for	
				90° Elbow	45° Elbow
* 4" Smooth Wall	50, 75, 100	50 or 60	80 ft (24.3M)	10 ft (3M)	5 ft (1.5M)
	125				
	150	60			
5" Smooth Wall	150	50	60 ft (18.3M)	10 ft (3M)	5 ft (1.5M)
	175	50 or 60			
	200	60			
* 4" Corrugated or Flexible	50, 75, 100	50 or 60	40 ft (12.2M)	N/A	N/A
	125				
	150				
5" Corrugated or Flexible	150	50	30 ft (9.1M)	N/A	N/A
	175	50 or 60			
	200	60			

\*Assumes the use of three feet (.9M) of flexible pipe at the combustion air inlet on the burner/control box

If the air inlet terminal is located adjacent to the exhaust terminal, the terminals must be separated by a minimum distance of three feet (.9M). The only exception is when the air inlet is located directly below the horizontal vent cap. The required clearance between an air inlet terminal located directly below the vent cap is 18 inches (457mm) as illustrated in **FIGURE 27B**. See **FIGURES 26B and 27B** in Paragraph 6.4.1 for illustrations and clearance requirements of an air inlet terminal located adjacent to the heater vent terminal.

## 7. Electrical and Wiring

**WARNING: If you turn off or disconnect the electrical power supply, turn off the gas. See Hazard Levels, page 2.**

All electrical wiring and connections, including electrical grounding MUST be made in accordance with the National Electric Code NFPA No. 70 (latest edition) or, in Canada, the Canadian Electrical Code, CSA Standard C22.1. The installer should also be aware of any local ordinances or gas company requirements that might apply. The heater must be electrically grounded and connected to a separately fused circuit with a disconnect as required by the National Electrical Code.

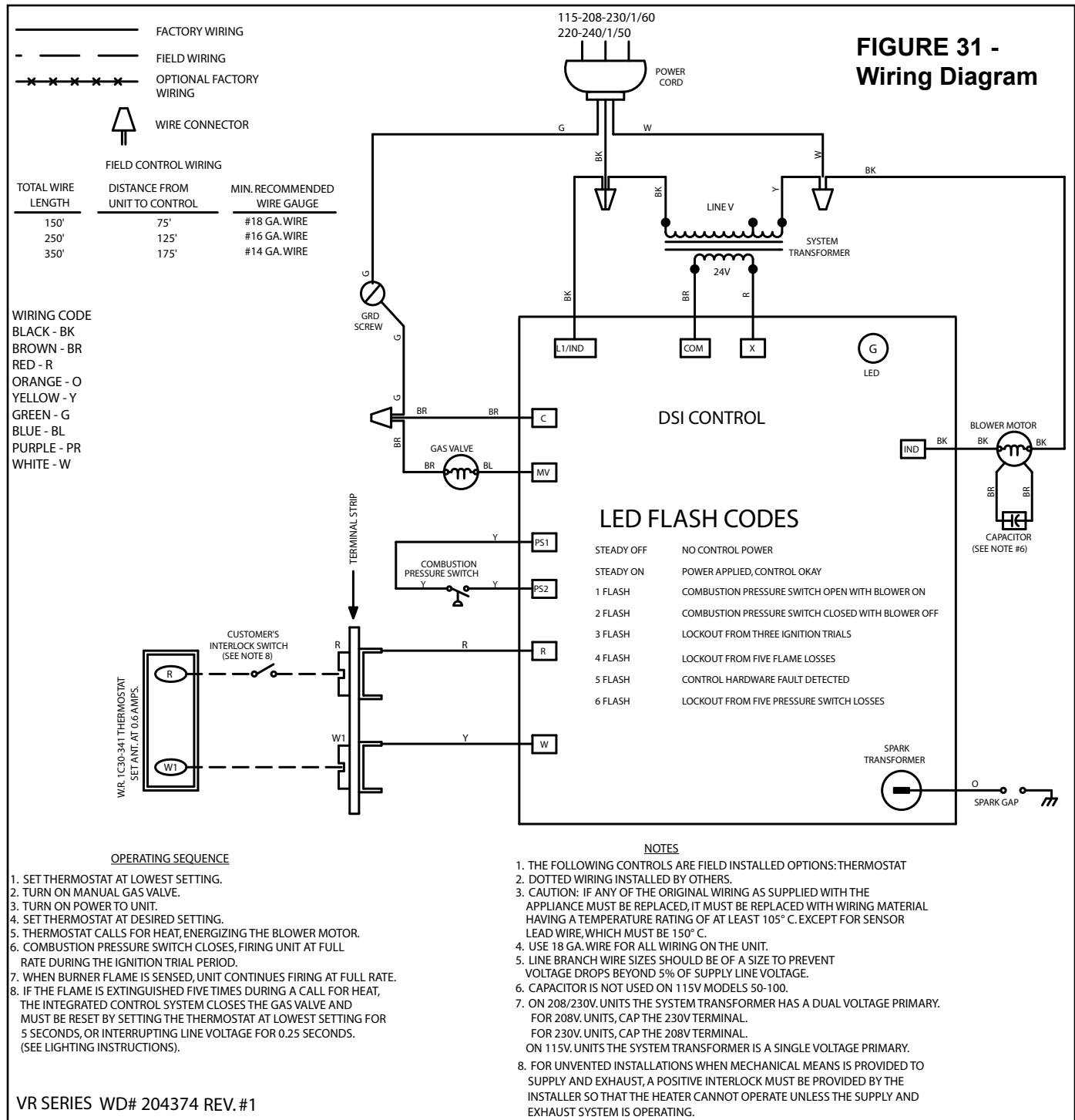
Heaters have a grounded plug-in cord. Be sure the outlet used provides the appropriate supply voltage. Allow slack in the electrical cord. Loop excess and bind loosely with wire tie or electrical tape.

## 7. Electrical and Wiring (cont'd)

### 7.1 Wiring Diagram

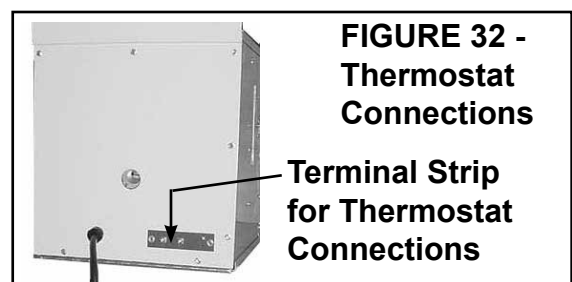
If the heater has field-installed options that require electrical connections, consult the instruction sheet and wiring diagram supplied in the option package.

Refer to the wiring diagram in **FIGURE 31** or the diagram on the burner control box door.



### 7.2 Control Thermostat

The heater is designed for automatic control from a remotely positioned or optional unit-mounted 24-volt thermostat and is equipped with a terminal strip to facilitate thermostat connections. See **FIGURE 32**.



Use either an optional thermostat (Option CL1) or a field-supplied 24-volt thermostat. Do not attempt to operate with a line voltage thermostat. Locate a remote thermostat on an inside wall in the heated area but not in the direct path of the infrared rays. See the wiring diagram in **FIGURE 31** or inside the heater door panel.

### **Unit-Mounted Thermostat Bracket, Option CM3**

The optional thermostat bracket kit allows attachment of the controlling thermostat to the burner/control box. The bracket attaches at the same location as the thermostat strip and includes a junction box for mounting the thermostat. Complete instructions are included with the option kit.

The thermostat is not included in the kit. The low voltage thermostat may be either an optional thermostat (Option CL1) or an equivalent field-provided thermostat.

### **Multiple-Heater Control, Option CL31 and CL32**

Options are available to permit control of up to six heaters from a single thermostat or a time clock and single/multiple thermostats. For maximum safety, the multiple control is done in the low voltage circuit. Complete instructions are included in each Option Kit.

## **8. Check Installation and Start-Up**

**NOTE:** On initial start-up, verify that any excess corrosion inhibitor has been wiped from the heat exchanger tubes. Failure to do so could result in excessive smoke from the surface of the tubes.

### **Check the installation prior to start-up:**

- Does the installation comply with all electrical and gas codes?
- Does the installation comply with required clearances? Requirements are shown in Paragraph 4.3. Signs are **required** specifying maximum permissible stacking height underneath the heater.
- If required, was the manifold pressure adjusted for high altitude? Sizes 50-175, was a high altitude pressure switch installed? See Paragraphs 6.1 and 6.3.
- If required, was a size conversion kit installed? See Paragraph 3 and 6.1.
- Are turbulator strips installed? See Paragraph 6.2.
- Is the system hung securely according to the instructions? See Paragraph 6.2. Are the "S" hooks closed? Are coupling bolts tight?
- Has all of the protective film been removed from the reflectors? Have the reflector been installed with appropriate SLIP and NON-SLIP overlaps? Is there 1/4" (6mm) space between the combustion chamber reflector and the burner/control box? Are the reflectors screwed to the tube brackets as required? If exposed to wind gusts, do straight reflectors have two retainers? See Paragraph 6.2.
- Is the system level? Before initial start-up, it is important that the system be checked again to be sure that it is level. Use a spirit level and check the burner and all sections of tubes. If the tubes are not level, hot spots could occur causing premature failure. Check all sections including "L" and "U" tubes. Adjust turnbuckle or chain as required.
- Is the vent installed properly and supported securely? See Paragraph 6.4.
- Has the system been checked for gas leaks? Has the gas supply pressure been verified? Will the gas connection allow for expansion and contraction? See Paragraph 6.3.

### **Start-Up:**

- Bleed all air from the gas supply lines to the heater. Rotate the knob on the combination valve to the "ON" position.  
Set the thermostat to above room temperature. This heater is equipped with a fully automatic ignition; do not attempt to light by hand. Listen for the quiet

## 8. Check Installation and Start-Up (cont'd)

### Start-up (cont'd):

hum of the combustion air motor. With combustion air motor operating, the spark at the burner will be visible. As the air bleeds from the gas line, the burner will try to ignite.

Once established, the main burner flame will burn directly off the face of the burner. Natural gas burners will have a blue flame with very little yellow tipping. Propane fueled burners will also have a blue flame, but the flame will have some yellow tipping. (NOTE: On initial start-up, there will be some odor and light smoke released from the tubes and reflectors).

Operate the heater for at least ten minutes to bring it to full temperature to ensure proper operation.

### Check installation after start-up:

- With the unit operating, measure manifold gas pressure. See Paragraph 6.3.
- Turn the unit off and on, pausing two minutes between each cycle. Observe for smooth ignition.
- Place "Owner's Envelope" containing the Warranty Form and this manual in a safe, accessible location near the heater. Observe clearances; do not place envelope in direct line of radiant heat.
- After initial startup, wait until tubes have cooled and check the tightness of all the tube coupling bolts. Tighten as needed.

---

**DANGER: The gas burner in a Model VR and Model GVR heater is designed and equipped to provide safe, complete combustion. However, if the installation does not permit the burner to receive the proper supply of combustion air, complete combustion may not occur. The result is incomplete combustion which produces carbon monoxide, a poisonous gas that can cause death. These tubular infrared heaters may be safely operated in the vented or unvented mode. FAILURE TO PROVIDE PROPER VENTING OR TO MEET FRESH AIR REQUIREMENTS FOR UNVENTED INSTALLATIONS WILL RESULT IN A HEALTH HAZARD THAT COULD CAUSE SERIOUS PERSONAL INJURY OR DEATH.**

**Always comply with the combustion air requirements in the installation codes and instructions. If combustion air is brought from outside, use only the outside combustion air kit specifically designed for this heater. NEVER RESTRICT OR OTHERWISE ALTER THE SUPPLY OF COMBUSTION AIR TO ANY HEATER. Indoor units installed in a confined space must be supplied with air for combustion as required by Code and in this heater installation manual. If two heaters use the same vent terminal, a specially designed dual vent kit must be installed. If the unit is vented, MAINTAIN THE VENT SYSTEM TO BE STRUCTURALLY SOUND AND IN FREE FLOWING OPERATING CONDITION. If the unit is unvented, PROVIDE 4 CFM OF FRESH AIR PER 1000 BTUH'S FOR NATURAL GAS OR 5 CFM OF FRESH AIR PER 1000 BTUH'S FOR PROPANE.**

---

## 9. Maintenance

### 9.1 Maintenance Requirements

As with any gas-burning equipment, regular maintenance procedures are required to ensure continued safety, reliability, and efficiency of the installation.

If service is required, this heater should be serviced only by a qualified service person. Service information in this booklet is intended as a guideline for a qualified gas-fired equipment service person.

Model VR and GVR tubular infrared heaters are designed to need only a minimum amount of maintenance. Some maintenance procedures outlined in this Section require inspection only, and some require action. All of the procedures described should be performed annually. Depending of the environment and the number of operating hours, more frequent cleaning may be required to certain components as indicated in the instructions for that component. Although the maintenance requirements for this heater are minimal, the routine maintenance procedures in this Section are necessary to ensure safe, reliable, and/or efficient operation.

The paragraphs which follow discuss the components and systems that require routine inspection/maintenance. At the beginning of each section, there is a code indicating the main reason why that maintenance procedure is necessary. The legend for that code is shown below.

Maintenance Code	Reason for Maintenance
<b>S</b>	Safety (to avoid personal injury and/or property damage)
<b>R</b>	Continued Reliability
<b>E</b>	Efficient Operation

### 9.2 Maintenance Procedures

#### 9.2.1 Flexible Gas and Electrical Supply Connections

**S** Expansion and contraction of the heater causes these components to be flexed on each completed heating cycle. Carefully inspect the flexible gas connector for any evidence that a fatigue crack has developed or is developing. If the inspection indicates that replacement is needed, replace the connector with an equivalent one (particularly the internal diameter because flexible connectors have large pressure losses).

Inspect the electrical supply connection for any insulation damage, and replace it if any irregularities are noted.

#### 9.2.2 Combustion Chamber Tube

**S** Check the combustion chamber tube for any evidence of burnout. A burned-out combustion chamber could allow fire to escape outside of the tube. If a burnout or weakness in the combustion chamber is discovered, the cause should be established and the tube replaced before heater operation is resumed. Burnout is the evidence of excessive flame temperature. Excessive flame temperature would most likely be caused by a restriction in the system or excessive gas pressure.

#### 9.2.3 Heat Exchanger Tubes

**S** Check all of the heat exchanger tubes for any indications of a hole developing. A hole in a heat exchanger tube would allow flue products and/or flame to escape into the heated space. Replace any suspect heat exchanger tube.

## 9. Maintenance (cont'd)

### 9.2 Maintenance Procedures (cont'd)

#### 9.2.4 Vent Pipe

**S** During a “cold” startup, transient condensation is formed. Over a period of time, condensation will cause metal pipe to develop holes and eventually fail completely. Replace any vent pipe that has condensation damage. The vent pipe system should be maintained at a quality where all flue products will be conveyed through the vent pipe to the outdoors.

If equipped with an optional dual vent kit, remove the cover from the dual vent adapter box to check the inner pipe.

#### 9.2.5 Connection Couplings

**S** Check the bolts and screws on the tube couplings for tightness. Loose couplings will allow flue products and/or flame to escape into the heated space. Tighten all bolts and screws. Replace if damaged.

#### 9.2.6 Vent and/or Combustion Air Terminal

**R** To prevent the pressure switch from cycling, check the vent terminal and the combustion air inlet terminal (if equipped with the combustion air inlet option) for any restrictions and/or damage. Clean if restricted, and replace if damaged.

#### 9.2.7 Combustion Air System

**R S** During an average heating season, approximately 65 tons of air pass through a Size 100 burner. That air is always carrying some dirt. Obviously, the amount of dirt varies with the environment. As the air passes through, some of that dirt is deposited on the combustion air intake, on the combustion air blower wheel, and inside the main burner. This buildup of dirt will eventually affect the operation of the heater. To maintain safe and reliable heater operation, an annual cleaning (more frequently in dirty environments) is recommended.

**Instructions for Cleaning the Combustion Air Blower (requires a wire brush, cleaning cloth, and an automotive-type aerosol degreaser or refrigerant coil cleaner):**

**CAUTION: Use of eye protection is recommended.**

1) Turn off the electrical supply to the heater, open the control access panel, and rotate the knob on the gas valve to the “OFF” position.

2) If using outside air for combustion, remove the combustion air inlet cover (Refer to **FIGURE 33**). It is not necessary to disconnect the pipe. Remove the inlet cover with the pipe attached.

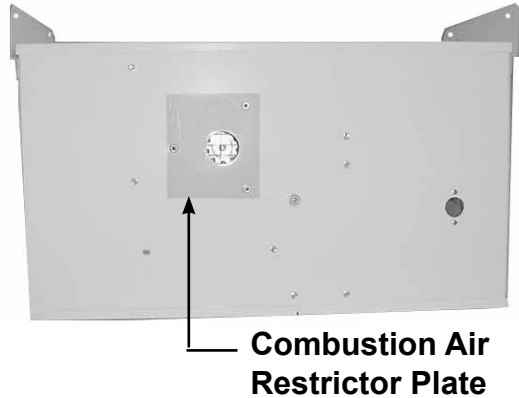
**FIGURE 33 - Combustion Air Inlet Cover used with Optional Outside Combustion Air**



3) Open the burner access panel on the bottom of the burner/control box. Either (1) cover the air inlet to the main burner to prevent foreign debris from entering the burner tube or (2) remove the burner for cleaning (Refer to Paragraph 34 on Cleaning the Main Burner).

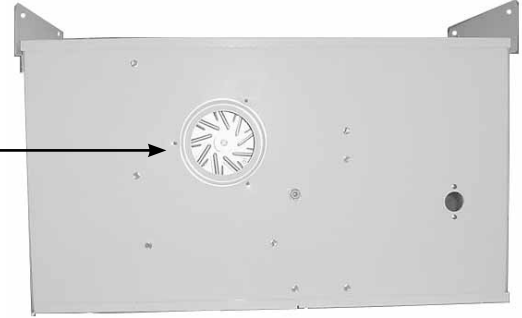
4) Remove the combustion air restrictor plate (**FIGURE 34**) and screen. The combustion air blower wheel is now visible (**FIGURE 35**).

**FIGURE 34 - Remove Combustion Air Restrictor Plate**



**FIGURE 35 - Clean the Blower Wheel**

**Blower Wheel**



**Clean the blower wheel using a brush, low-pressure compressed air, and an aerosol degreaser or refrigerant coil cleaner. Be careful not to damage the blower wheel. Replace the restrictor plate.**

- 5) Clean the blower wheel. Remove any dust, dirt and/or oily deposits. Non-oily deposits can be removed with a small brush and low-pressure compressed air. Be careful not to damage the blower wheel. Use an aerosol degreaser (available in automotive stores) or a refrigerant coil cleaner to clean oily deposits.
- 6) Clean the inside of the burner/control box. Remove any dirt/debris that collected during normal operation and from the wheel-cleaning process. Do not let any foreign material enter the main burner or collect on the spark electrode assembly.
- 7) Clean and re-install the combustion air screen and restrictor plate. If equipped with a combustion air inlet cover, clean and re-install it on the heater.
- 8) Close the access panels. Restore the electric and the gas. Test fire the heater and check for proper operation.

## 9.2.8 Main Burner

**R**

**S**

Excessive dirt buildup on and inside the concentric port rings on the main burner could cause fuel gas to spill out of the back of the burner tube. Fuel gas spilling out of the back of the burner tube will cause gas odor inside the building, and if not corrected, could eventually cause a fire/explosion hazard. To prevent fuel gas spilling from the back of the burner tube, clean the main burner ports at least annually.

**Instructions for Removing and Cleaning the Main Burner (requires Phillips screwdriver, 1/4" nut driver, 1-1/8" open end wrench, a wire brush, cleaning cloth, and an automotive-type aerosol degreaser or refrigerant coil cleaner):**

**CAUTION: Use of eye protection is recommended.**

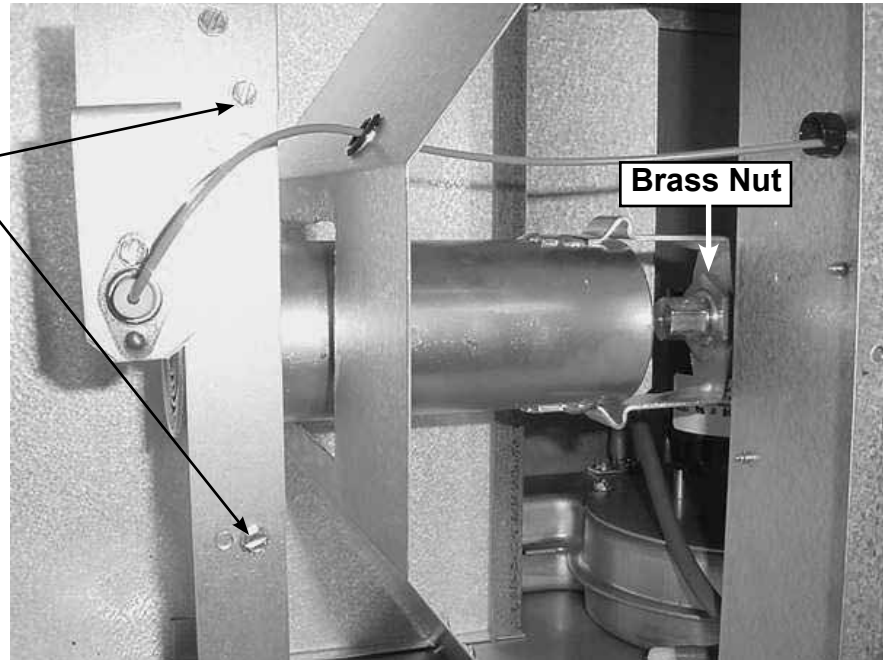
- 1) Turn off or disconnect the main electric supply.
- 2) Open both the control and burner access panels.
- 3) Rotate the knob on the gas valve to the "OFF" position.
- 4) While supporting the front of the burner, remove the two screws that retain the main burner (Refer to **FIGURE 36A**). Remove the brass nut located at the rear of the burner. Slide the burner toward the combustion chamber, carefully manipulate, and remove the burner from the burner/control box.
- 5) Remove any soot deposits from the burner with a wire brush. (See **FIGURE 36B**.) Clean between the port rings with an aerosol degreaser and/or compressed air. Wipe the inside of the burner tube clean. (Cleaning the burner with an aerosol degreaser is highly recommended as the degreaser will retard future buildup of dirt.)

## 9. Maintenance (cont'd)

### 9.2 Maintenance Procedures (cont'd) 9.2.8 Main Burner (cont'd)

**FIGURE 36A - Open the Burner Compartment and Remove the Burner**

First, remove these two screws.  
Then, supporting the front of the burner, remove the brass nut at the other end.  
Remove burner.



**FIGURE 36B - Burner Removed for Cleaning**



- 6) Inspect the cleaned burner for any damage or deterioration. If the burner has any damage or signs of deterioration, replace it. Carefully reverse the above procedures to re-install or replace the burner.  
Test the heater for proper operation.

#### 9.2.9 Spark Electrode Assembly

**CAUTION: Due to high voltage on the spark wire and electrode, do not touch when energized. See Hazard Levels, page 2.**

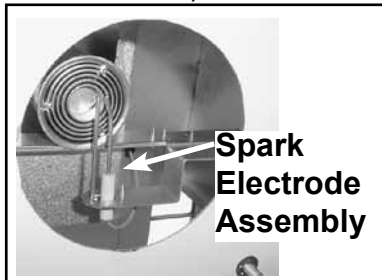
**R** The spark electrode assembly performs several necessary functions, and to ensure reliable service, it must be cleaned periodically. The required frequency of cleaning will vary depending on the installation site and the hours of operation. No less than annual cleaning is recommended.

One of the most important reasons for cleaning the spark electrode assembly is that the DC current needed to prove the burner must flow through the electrode. That current can either be retarded or totally blocked by deposits and/or corrosion on the electrode.

**Instructions for Removing and Cleaning the Spark Electrode Assembly (requires phillips screwdriver, 1/4" nut driver, and emery cloth):**

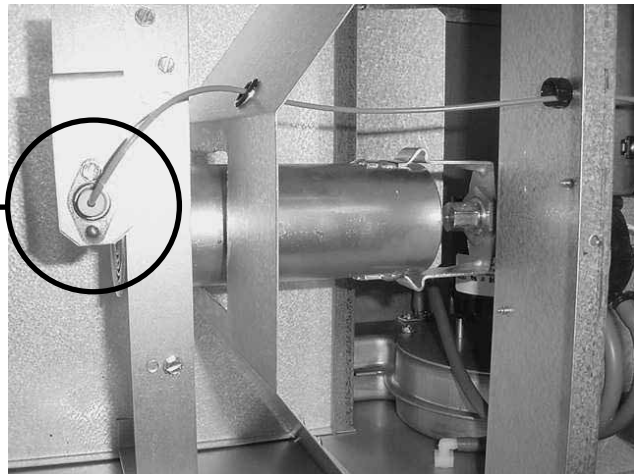
- 1) Turn off or disconnect the main electric supply.
- 2) Open the control access panel. Rotate the knob on the gas valve to the "OFF" position. At the ignition controller, disconnect the high voltage spark electrode wire.
- 3) Open the burner access panel. Remove the screws and the spark electrode assembly (Refer to **FIGURES 37A and 37B**).
- 4) Use an emery cloth to clean the two metal rods on the spark electrode. Clean until they are bright. Wipe off the ceramic insulator.
- 5) The spark gap must be maintained to 1/8" as illustrated in **FIGURE 37C**.
- 6) Re-assemble, reversing above procedure. Test the heater for proper operation.

**FIGURE 37A - Spark Electrode Assembly as seen through the front of the box (only visible when the combustion chamber is not attached.)**

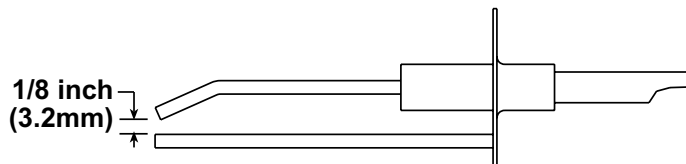


**FIGURE 37B - Remove Spark Electrode Assembly**

Remove the screw and carefully remove the spark electrode assembly.



**FIGURE 37C - Spark Gap**



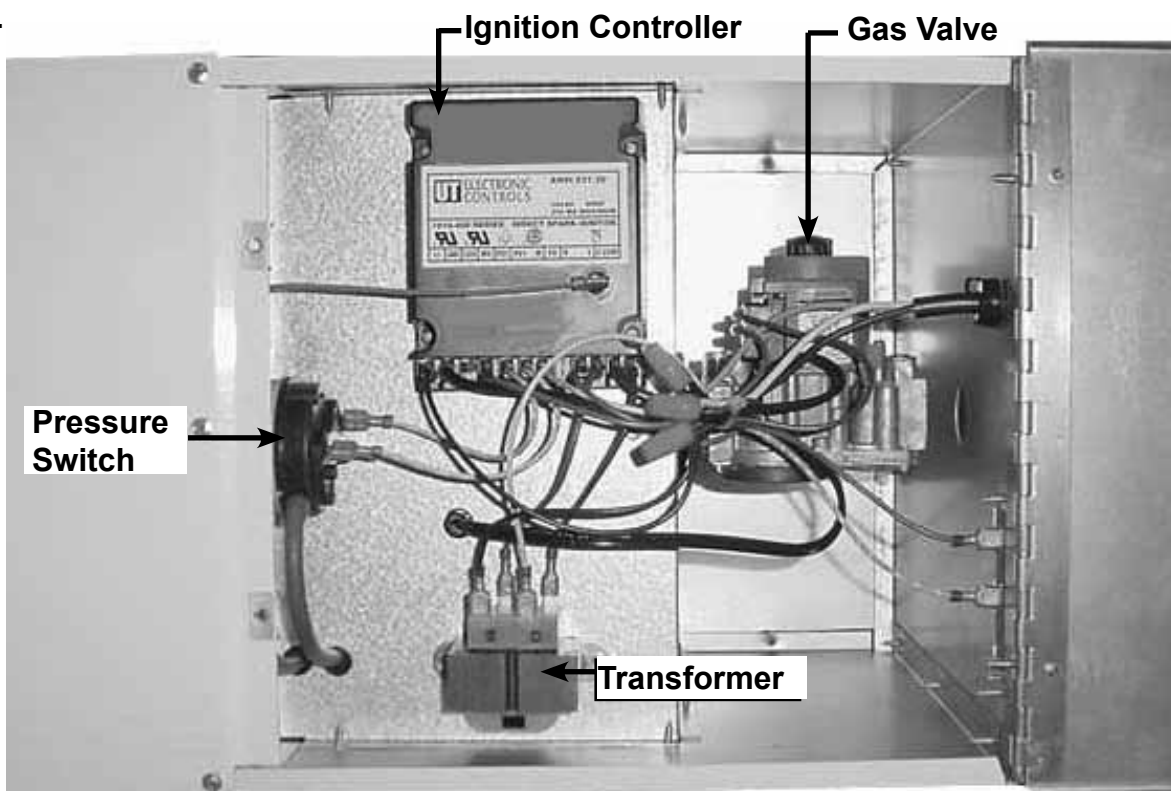
## 10. Service

### 10.1 Control Location, Operation, and Service

To service this heater, it is necessary to understand the normal operating functions of the heater controls. Refer to **FIGURE 38** and to the individual illustrations to identify and locate each of the controls.

**WARNING: Service work on this heater should only be done by a qualified gas service person. This service information and the troubleshooting guides are intended as an aid to a qualified service person.**

**FIGURE 38 - Control Locations**



## 10. Service (cont'd)

### 10.1 Control Location, Operation, and Service (cont'd)

**FIGURE 39 - Pressure Switch**



**NOTE:** A Model VR/GVR 50-175 operating above 6000 ft (1830M) elevation requires a high altitude pressure switch. See Paragraph 6.1.

## Pressure Switch

**Function** - The pressure switch is a safety control to ensure that adequate air is being provided for proper combustion. The device “senses” a small differential pressure created by the flow of the combustion air.

**Sensing Pressure Check** (requires a Phillips screwdriver, a sensitive slope gauge, several feet of 3/16” O.D. rubber tubing, and two 1/4” O.D. barbed tees)

- 1) Disconnect the electrical supply and open the control compartment door.
- 2) Using one of the tees, attach tubing to one side of the pressure switch so that the switch will continue to sense pressure. Repeat on the other side of the pressure switch.
- 3) Connect the tubing to the slope gauge being careful not to “mix” the tubes.
- 4) Turn on the electrical power, and set the room thermostat above room temperature.
- 5) On the slope gauge, take the “cold” readings. If the “cold” sensing pressure is sufficient to cause the pressure switch to close, observe at what sensing pressure the switch opens (“hot”).

Model VR (60 Hz) Combustion Air Pressure Switch Settings								
Size	Pressure Switch P/N	Label Color	Normal Sensing Pressure Range (“w.c.”)				Setpoint	
			Indoor Combustion Air		Outdoor Combustion Air		“OFF”	“ON”
			Cold	Hot	Cold	Hot		
50	205442	White	0.75 - 0.65	0.65 - 0.55	0.72 - 0.62	0.60 - 0.50	0.20	0.25
75			0.85 - 0.75		0.75 - 0.65			
100			1.70 - 1.40	1.35 - 1.15	1.65 - 1.35	1.20 - 1.00		
125	205443	Yellow	1.80 - 1.50	1.30 - 1.10	1.60 - 1.30	0.75	0.80	
150			2.50 - 2.20	1.80 - 1.55	2.30 - 2.00			1.60 - 1.35
175	205444	Green	2.00 - 1.70	1.10 - 0.85	1.70 - 1.40	0.80 - 0.55	0.30	0.35

Model VR or Model GVR (50 Hz) Combustion Air Pressure Switch Settings								
Size	Pressure Switch P/N	Label Color	Normal Sensing Pressure Range (“w.c.”)				Setpoint	
			Indoor Combustion Air		Outdoor Combustion Air		“OFF”	“ON”
			Cold	Hot	Cold	Hot		
50	205442	White	0.65	0.50	0.60	0.50	0.20	0.25
75			0.75	0.50	0.65	0.40	0.20	0.25
100			0.70	0.45	0.60	0.40	0.20	0.25
125	197032	Pink	1.10	0.80	1.00	0.65	0.45	0.50
150	205444	Green	1.10	0.60	1.00	0.50	0.30	0.35
175	197031	Purple	1.10	0.50	0.80	0.50	0.35	0.40

**WARNING: If replacement of the pressure switch is necessary, replace with the identical model pressure switch only. Do not substitute.**

**Service** - The pressure switch is a very reliable device which has no field-repairable parts and seldom needs to be replaced. Usually a pressure sensing problem is an indication that there is a problem with the vent pipe and/or combustion air inlet. The most likely causes of low sensing pressure are listed below.

- On new installations, the cause is usually due to either too much vent pipe, too much combustion air inlet pipe, and/or the use of non-specified terminals. (See Paragraphs 6.2 and 6.4.)
- On units that are not equipped with an outside combustion air inlet, low sensing pressure may be caused by negative building pressure. When negative building pressure exists, install an outside combustion air inlet.
- An obstruction in the vent pipe or combustion air inlet. Remove obstruction.
- A dirty combustion air blower wheel. See Maintenance Section, Paragraph 9.2.7, for cleaning instructions.

Check the installation, make necessary changes, and re-check the sensing pressure. If it should be determined that the pressure switch needs to be replaced, replace with an identical switch only. Do not substitute.

## Ignition Controller

**FIGURE 40 - Ignition Controller**



**Function** - The ignition controller functions to ignite the burner and as a flame supervision device. The ignition controller will shut off main burner gas flow immediately if the burner flame is lost.

Burner ignition is achieved by a high voltage (18kV) spark that occurs across the spark electrode. The proper gap and location are important.

**CAUTION: Do not attempt to measure flame current signal. Attempting to do so can result in high voltage shock and/or damage to the meter.**

The presence of the flame is detected by the ignition controller's sensing circuit when a DC current flows through the spark electrode assembly. A current flow of at least 1.0 microamps is required for flame detection.

## Combination Gas Valve

**FIGURE 41 - Gas Valve**



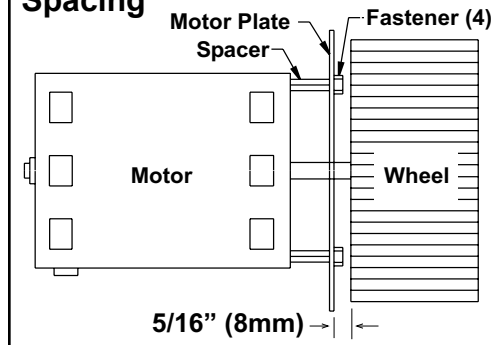
**Function** - The combination valve provides a number of functions. It automatically controls the gas flow to the burner. It regulates the burner gas pressure; and it contains a manual valve for complete interruption of the gas flow. The combination valve also has pressure tap ports for measuring inlet (supply) gas pressure and manifold gas pressure. See Paragraph 6.3 for proper inlet gas pressure range and instructions on checking outlet pressure.

Normally, it is not necessary to adjust the manifold gas pressure. Do not attempt to correct for low inlet (supply) pressure by adjusting the pressure regulator. Adjusting the pressure regulator on the combination gas valve will not increase the supply pressure, and if at a later time, the inlet pressure is increased, an unsafe condition could result. .

**Service** - The combination valve has no field-repairable parts.

## Combustion Air Blower System

**FIGURE 42 - Motor and Wheel Spacing**



**Function** - The function of the combustion air blower system is to provide a metered flow of air to the burner for proper combustion of the fuel gas. The quantity of airflow also serves to control the temperature of the radiating surfaces. The combustion air blower system is comprised of the combustion air orifice, the blower wheel, the blower housing, and the blower motor.

**Service** - This system contains no field serviceable parts. If any components become defective, it must be replaced. The blower motor is permanently oiled and requires no additional oiling. For proper blower motor operation, the voltage supplied to the motor must be within a suitable range. If any part(s) must be replaced, the correct blower wheel spacing must be maintained. Refer to **FIGURE 42** and Maintenance Section, Paragraph 9.2.7. Use only replacement parts identical to the factory-installed parts.

## Transformer

**FIGURE 43 - Transformer**



**Important Note:** To prolong the life of the transformer, do not short the "hot" side of the transformer to ground when servicing the heater. Doing so will cause the transformer to fail.

**Function** - The function of the transformer is to reduce the supply voltage to a 24-volt circuit in order to operate the 24-volt controls.

**Transformer Check** (requires a voltmeter) - To verify the 24-volt circuit, checking the operation of the transformer, set the thermostat to above room temperature. Using a voltmeter, check the voltage between Terminal R on the thermostat terminal strip (on the burner/control box) and the ground terminal on the ignition controller. If there is no voltage in this circuit, the transformer is not functioning. The service of a transformer is like that of a light bulb; it is either good or bad, and when bad, it must be replaced.

**Service** - If replacement of the transformer is necessary, do not substitute any other transformer. Use a replacement transformer IDENTICAL to the factory-installed model. The electrical compartment is not intended to be pressurized, and replacement of another type transformer could cause combustion air leakage.

## 10. Service (cont'd) 10.2 Troubleshooting

**WARNING: Service work on this heater should only be done by a qualified gas service person. All service information including the Troubleshooting Guides is intended as an aid to a qualified service person.**

### Check the Light on the DSI Control Board

LED Codes	
No power	Steady OFF
Power applied, control OK	Steady ON
Pressure switch open with blower motor ON	1 FLASH
Pressure switch closed with blower motor OFF	2 FLASHES
Lockout from too many ignition trials	3 FLASHES
Lockout from too many flame losses	4 FLASHES
Control hardware fault detected	5 FLASHES
Lockout from too many pressure switch losses	6 FLASHES

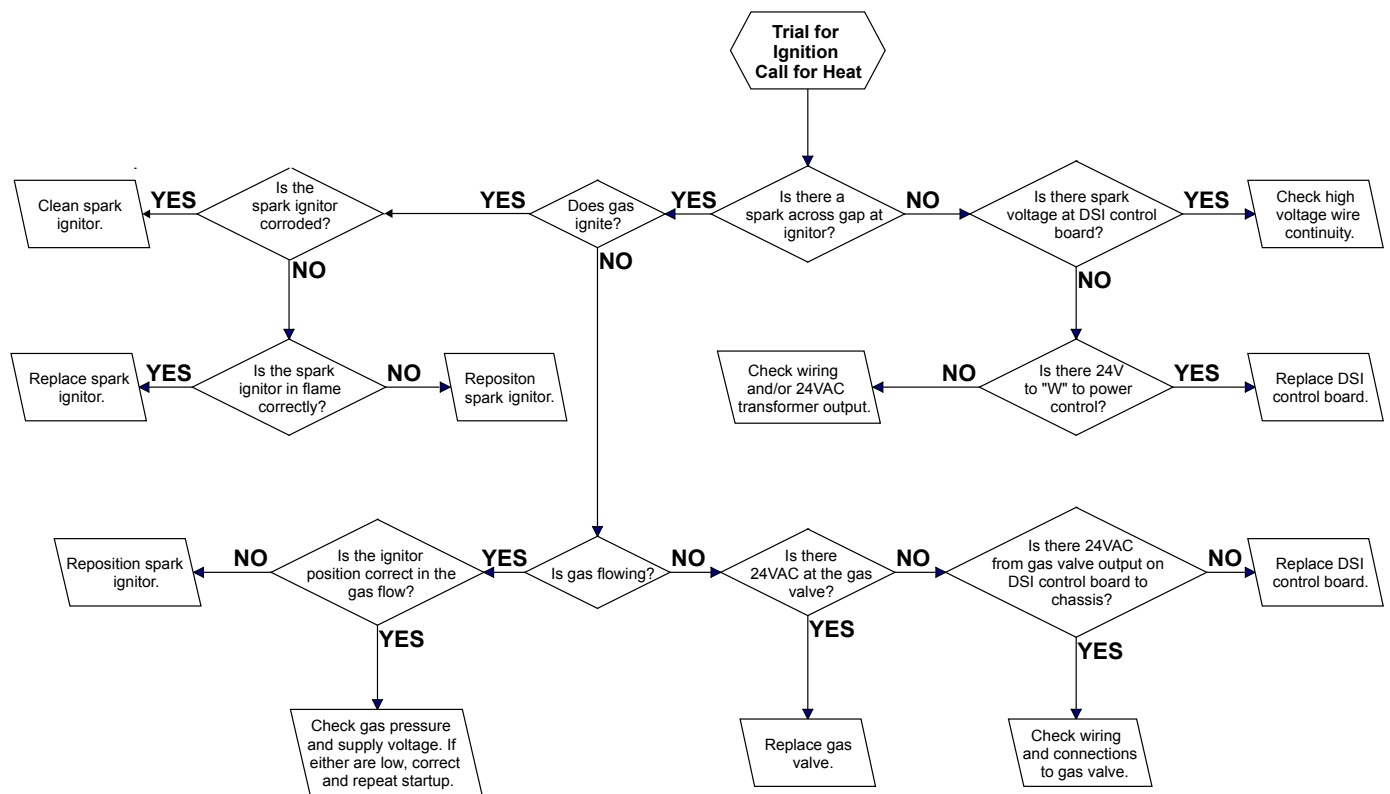
The DSI control board monitors the operation of the heater and includes a LED signal light that indicates normal operation and various abnormal conditions. If the heater fails to operate properly, check this signal to determine the cause and/or to eliminate certain causes. See operation sequence on the Wiring Diagram in **FIGURE 31** or on the heater.

Do not attempt to repair the DSI control board.

PROBLEM	PROBABLE CAUSE	REMEDY
<b>Blower motor will not start</b>	<ol style="list-style-type: none"> <li>No power to unit.</li> <li>No 24 volt power to DSI control board.</li> <li>No power to blower motor.</li> <li>DSI control board defective.</li> <li>Defective blower motor.</li> </ol>	<ol style="list-style-type: none"> <li>Turn on power; check supply fuses or main circuit breaker.</li> <li>Turn up thermostat; check control transformer output.</li> <li>Tighten connections at DSI board and/or motor terminals.</li> <li>Replace DSI control board.</li> <li>Replace blower motor. See Paragraphs 9.2.7 and 10.1.</li> </ol>
<b>Burner will not light</b>	<ol style="list-style-type: none"> <li>Manual valve not open.</li> <li>Air in the gas line.</li> <li>Gas pressure too high or too low.</li> <li>No Spark:               <ol style="list-style-type: none"> <li>Loose wire connections.</li> <li>Transformer failure.</li> <li>Incorrect spark gap.</li> <li>Spark wire shorted to ground.</li> <li>Spark electrode shorted to ground.</li> <li>DSI board not grounded.</li> <li>Unit not properly grounded.</li> <li>Faulty DSI control board.</li> </ol> </li> <li>Lockout device interrupting control circuit by above causes.</li> </ol>	<ol style="list-style-type: none"> <li>Open manual valve.</li> <li>Bleed gas line (initial startup only).</li> <li>See Gas Supply Pressure Table, Paragraph 6.3.</li> <li> <ol style="list-style-type: none"> <li>Be certain all wire connections are solid.</li> <li>Be sure 24 volts is available.</li> <li>Maintain spark gap at 1/8".</li> <li>Replace DSI electrode assembly.</li> <li>Replace if ceramic spark electrode is cracked or grounded.</li> <li>Make certain DSI control board is grounded to furnace chassis.</li> <li>Make certain unit is properly field grounded to earth ground.</li> <li>If 24 volt is available to the DSI control board and all other causes have been eliminated, replace board.</li> </ol> </li> <li>Reset lockout by interrupting control at the thermostat for 5 seconds or main power for 0.25 seconds.</li> </ol>
	<ol style="list-style-type: none"> <li>Combustion air proving switch not closing.</li> <li>Faulty combustion air proving switch.</li> <li>Main valve not operating.               <ol style="list-style-type: none"> <li>Defective valve.</li> <li>Loose wire connections</li> </ol> </li> <li>DSI control board does not power main valve.               <ol style="list-style-type: none"> <li>Loose wire connections.</li> <li>Spark electrode assembly grounded.</li> </ol> </li> <li>Incorrect gas pressure.</li> <li>Cracked ceramic at spark electrode assembly.</li> </ol>	<ol style="list-style-type: none"> <li> <ol style="list-style-type: none"> <li>Make sure unit is properly vented.</li> <li>Remove obstructions from vent.</li> <li>Replace faulty tubing to pressure switch.</li> </ol> </li> <li>Replace combustion air proving switch.</li> <li> <ol style="list-style-type: none"> <li>If 24 volt is measured at the valve connections and valve remains closed, replace valve.</li> <li>Check and tighten all wiring connections.</li> </ol> </li> <li> <ol style="list-style-type: none"> <li>Check and tighten all wiring connections.</li> <li>Be certain spark electrode assembly lead is not grounded or insulation or ceramic is not cracked. Replace as required.</li> <li>See Gas Supply Pressure Table, Paragraph 6.3.</li> <li>Replace spark electrode assembly.</li> </ol> </li> </ol>

PROBLEM	PROBABLE CAUSE	REMEDY
<b>Burner cycles on and off</b>	1. Gas pressure too high or too low. 2. DSI control board not grounded. 3. Faulty DSI control board. 4. Combustion air proving switch not closing. 5. Faulty combustion air proving switch. 6. Spark electrode assembly grounded. 7. Cracked ceramic at spark electrode assembly.	1. See Gas Supply Pressure Table, Paragraph 6.3. 2. Make certain DSI control board is grounded to furnace chassis. 3. If 24 volt is available to the DSI control board and all other causes have been eliminated, replace board. 4. a) Make sure unit is properly vented. b) Remove obstructions from vent. c) Replace faulty tubing to pressure switch. 5. Replace combustion air proving switch. 6. Be certain spark electrode assembly lead is not grounded or insulation or ceramic is not cracked. Replace as required. 7. Replace spark electrode assembly.
<b>No heat (Heater Operating)</b>	1. Incorrect valve outlet pressure. 2. Improper thermostat location or adjustment.	1. Check valve outlet pressure. See Rating plate for valve outlet pressure. 2. See thermostat manufacturer's instructions.
<b>Blower motor will not run</b>	1. Circuit open. 2. Defective DSI control board. 3. Defective motor.	1. Check wiring and connections. 2. Replace board. 3. Replace motor.
<b>Blower motor turns on and off while burner is operating</b>	1. Motor overload device cycling on and off.	1. Check motor load against motor rating plate. Replace motor if needed.
<b>Blower motor cuts out on overload</b>	1. Low or high voltage supply. 2. Defective motor. 3. Poor air flow. 4. Defective bearing.	1. Correct electric supply. 2. Replace motor. 3. Clean motor and blower. 4. Replace motor.

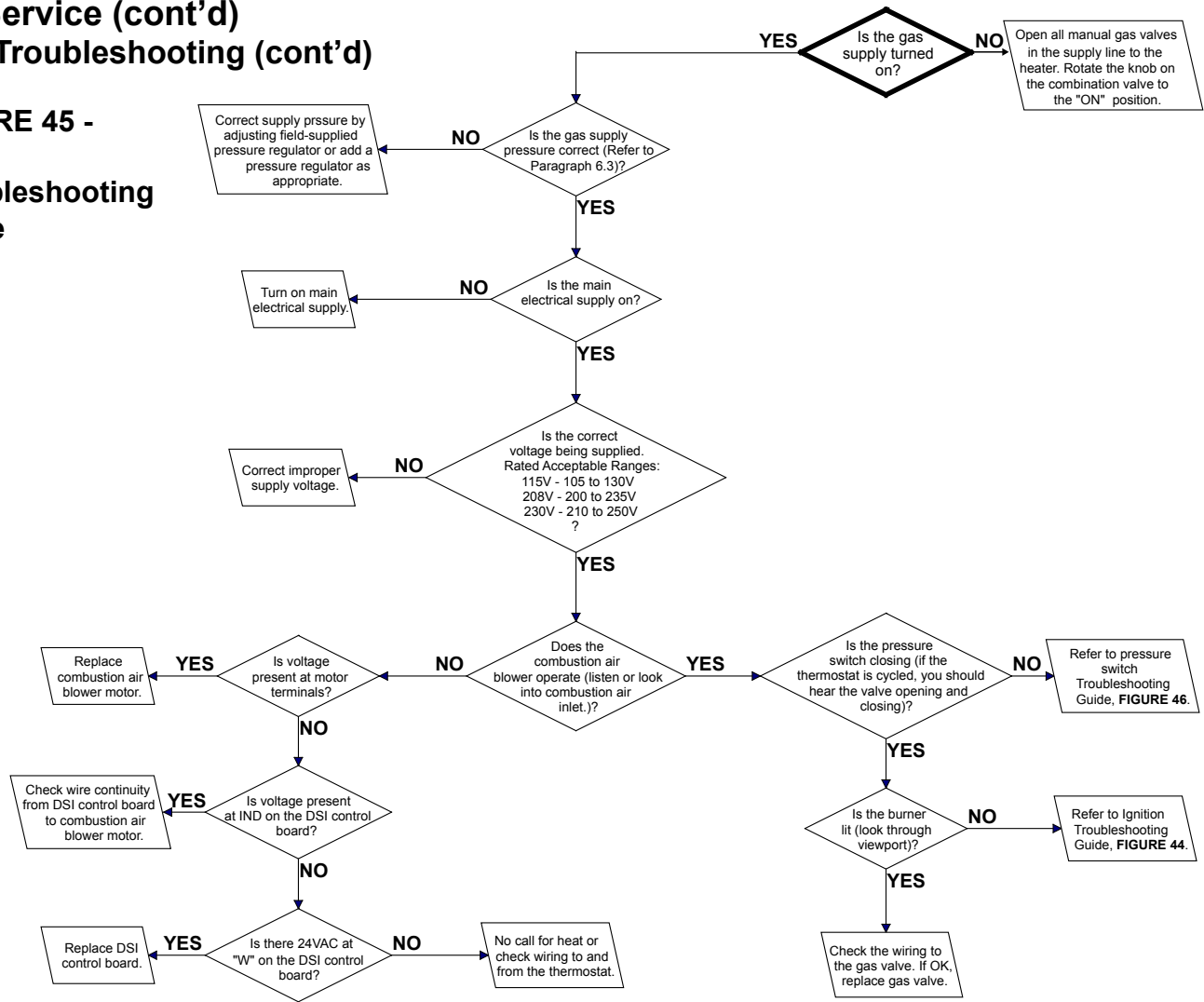
**FIGURE 44 - Ignition Troubleshooting Guide**  
**(Assumes pressure switch is actuated.)**



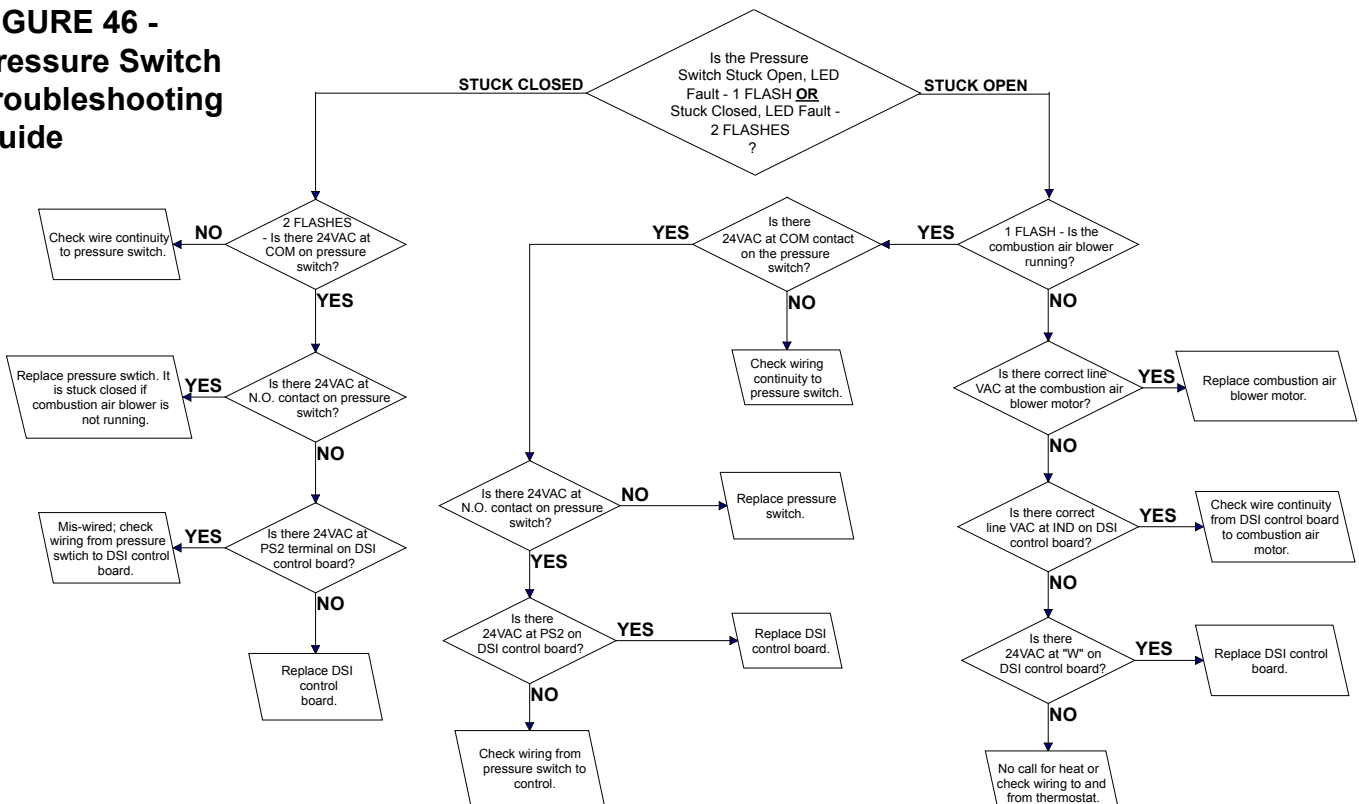
# 10. Service (cont'd)

## 10.2 Troubleshooting (cont'd)

**FIGURE 45 -  
Basic  
Troubleshooting  
Guide**



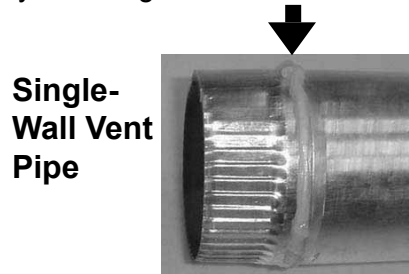
**FIGURE 46 -  
Pressure Switch  
Troubleshooting  
Guide**



**FIGURE 47 - Attaching Double-Wall (Type B) Pipe to Single Wall Pipe**

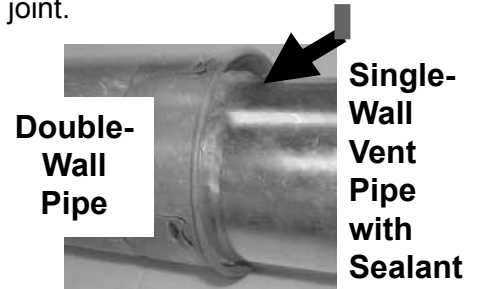
**FIGURE 47 - STEP 1**

On the single-wall pipe, where illustrated, place a continual 1/4 inch bead of silicone sealant around the circumference. Do STEP 2 immediately following STEP 1.



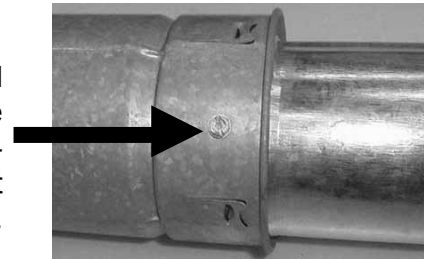
**FIGURE 47 - STEP 2**

Insert the single-wall pipe into the inner pipe of the double-wall pipe until the bead of sealant contacts the inner pipe creating a sealed joint.



**FIGURE 47 - STEP 3**

Spaced equally around the double-wall pipe, drill three small holes below the sealant ring. Insert 3/4 inch long sheet-metal screws to secure the joint. Do not over tighten screws.

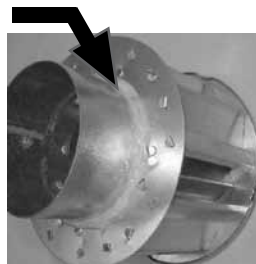


**NOTE:** Only single-wall vent pipe can be attached to the exhaust heat exchanger tube.

**FIGURE 48 - Attaching Double-Wall (Type B) Pipe to a Vent Cap**

**FIGURE 48 - STEP 1**

Place a continual 3/8" bead of silicone sealant around the circumference of the vent cap collar. This will prevent any water inside the vent cap from running down the double-wall pipe. Do STEP 2 immediately following STEP 1.



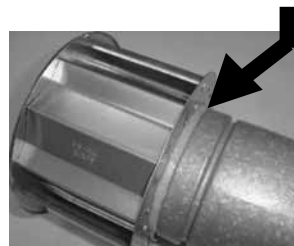
**FIGURE 48 - STEP 3**

Secure the vent cap to the double wall pipe by drilling and inserting a 3/4" long sheetmetal screw into the vent cap collar. Do not over tighten screw.



**FIGURE 48 - STEP 2**

Insert the collar on the vent cap inside the inner wall of the double-wall pipe. Insert as far as possible. Add additional silicone sealant to fully close any gaps between the vent cap and the double wall pipe. This is necessary to prevent water from entering the double wall pipe.



**Addendum  
(cont'd)**

**Electrical  
Characteristics**

**Model VR/GVR Technical Information**

<b>Model VR (std 60 Hertz)</b>				
<b>Voltage/Phase</b>	Standard 115/1; Optional 208/1, 230/1			
<b>Frequency</b>	60 hertz			
<b>Control Amps (24V)</b>	0.8			
<b>Main Burner Ignition</b>	Direct Spark			
<b>Full Load Amps</b>	Sizes 50, 75, and 100	Sizes 125 and 150	Size 175	Size 200
<b>115V</b>	1.1	0.8	1.2	1.2
<b>Optional 208V or 230V</b>	0.5	0.5	0.6	N/A
<b>Maximum Overcurrent Protection</b>	15	15	15	15

<b>Model VR (optional 50 Hertz) and Model GVR (std 50 Hertz)</b>			
<b>Voltage/Phase</b>	220-240/1 (Option AK11)		
<b>Frequency</b>	50 hertz		
<b>Control Amps (24V)</b>	0.8		
<b>Main Burner Ignition</b>	Direct Spark		
<b>Full Load Amps</b>	Sizes 50, 75, and 100	Sizes 125 and 150	Size 175
<b>Optional 220-240/1/50</b>	0.5	0.5	0.6
<b>Maximum Overcurrent Protection</b>	15	15	15

**Gas Type and Supply  
Gas Pressure**

<b>BTUH Input</b>	<b>Gas Type</b>	<b>Supply Pressure</b>	
		<b>Minimum</b>	<b>Maximum</b>
50,000 - 150,000	Natural Gas	4.5" w.c.	14" w.c.
175,000 - 200,000		6" w.c.	14" w.c.
50,000 - 200,000	Propane	11" w.c.	14" w.c.

**BTUH/Length/  
Configurations**

<b>BTUH Input</b>	<b>Minimum Length</b>	<b>Maximum Length</b>
50,000	20 feet (6.1M)	40 feet (12.2M)
75,000	20 feet (6.1M)	40 feet (12.2M)
100,000	30 feet (9.1M)	50 feet (15.2M)
125,000	30 feet (9.1M)	60 feet (18.3M)
150,000	40 feet (12.2M)	60 feet (18.3M)
175,000	40 feet (12.2M)	70 feet (21.3M)
200,000	50 feet (15.2M)	70 feet (21.3M)

**REFERENCES**

(Forms are available on Website [www.RezSpec.com](http://www.RezSpec.com) or from your Distributor.)

**Model VR/GVR Configuration Drawings..... Form T-VR-CNFG**

**Replacement Parts ..... Form P-VR/RIH**

# Index

## A

Accessory Cartons 6  
Addendum 45  
Angle Reflectors 20  
Assemble the Burner/Control Box and the Combustion Chamber Tube 11

## B

Blower Wheel 37  
BTUH/Length/Configurations 46  
Burner 37  
Burner/Control Box 9  
Burner/Control Box Packages 5  
Burner Orifice 10

## C

California Warning Label 3  
Chain 8  
Check Installation 33  
Clean the Burner 38  
Clearance Orientation 8  
Clearances to Combustibles 8  
Combustion Air 30  
Combustion Air Blower System 41  
Combustion Air Inlet Kit 31  
Combustion Air Pipe Length 31  
Combustion Air Restrictor Plate 10, 37  
Combustion Air System 36  
Combustion Chamber Tube 11, 35  
Compression Coupling 14, 25  
Condensation 26  
Configuration Drawings 46  
Configuration Requirements 6  
Confined Space 30  
Connect Combustion Chamber and Heat Exchanger Tube 14  
Connection Couplings 36  
Contact 48  
Control Locations 39

## D

Dimensions 7  
Double-Wall Vent Pipe 45  
DSI Control Board 42  
Dual Vent Terminal 28  
Dual Vent Terminal Kit 28

## E

Elbow 26  
Electrical and Wiring 31  
Electrical Characteristics 46  
Electrical supply connection 35  
Exhaust Heat Exchanger Tube 26  
Expansion 9

## F

Field Convert the Burner/Control Box Size 9  
Flexible Gas connector 22, 35

## G

Gas Connection Requirements 21  
Gasket 11

Gas Piping and Pressures 20  
Gas Pressure 46  
Gas Supply Pressure Table 20  
Gas Valve 22, 39, 41  
General 2

## H

Hanger Bar 12  
Burner Box Hangers 10  
Hanging Chain 13  
Hazard Levels 2  
“L” Heat Exchanger Tube 13  
“U” Heat Exchanger Tube 13  
Heat Exchanger Tubes 13, 35  
High Altitude Derate 23  
High Altitude Pressure Switch 11  
Horizontal Dual Vent Terminal 29  
Horizontal Vent 26  
Horizontal Vent Clearance Table 27  
Horizontal Vent Terminal Arrangements 27

## I

Ignition Controller 39, 40, 41  
Ignition Troubleshooting Guide 43  
Inputs by Altitude 24  
Installation Codes 3

## L

LED Codes 42  
Length of Outside Combustion Air Inlet Pipe 31  
Level the System 20  
Location 3

## M

Maintenance Procedures 35  
Maintenance Requirements 35  
Manifold Pressure Settings by Altitude 23  
Massachusetts Requirement 3  
Motor and Wheel Spacing 41  
Mounting Height Table 5  
Multiple-Heater Control 33

## O

NON-SLIP overlap 16  
Overlap 17  
SLIP overlap 17

## P

Packaging 5  
Parts 46  
Preparation INSTRUCTIONS 9  
Pressure Switch 10, 39, 40  
Pressure Switch Settings 40  
Pressure Switch Troubleshooting Guide 44

## R

Recheck Couplings and Tube Brackets 20  
REFERENCES 46  
Reflector End Covers 19  
Reflector Installation Instructions 16  
Reflector Overlaps (Straight Systems) 18

“U” or “L” Tube Reflectors 18  
Reflectors 16  
Wire Reflector Retainer 12

## S

“S” Hook 13  
Service 39  
Side Shield Installation Instructions 19  
Side Shields 18  
Spark Electrode Assembly 38  
Spark Gap 39  
Special Installations 3  
Start-Up 33  
Straight Lengths by Size 7  
Straight System Length 9  
Suspend the Assembled Burner/Control Box 11, 12  
Suspension point 9  
Suspension Requirements 8

## T

Technical Information 46  
Thermostat 32  
Thermostat Bracket 33  
Thermostat Connections 32  
Transformer 39, 41  
Troubleshooting 42  
Troubleshooting Guide 44  
Tube Bracket 12, 13  
Tube Coupling 13  
Tube Packages 6  
Turbulator Requirements 15  
Turbulator Strip 13, 14  
Turbulator Strip Sections 15  
Turnbuckle 9

## U

U-bolt and nuts 12  
Uncrating 5  
Unvented Installation 29

## V

Valve Outlet Pressure 22  
Vent and/or Combustion Air Terminal 36  
Vent Cap 26  
Vent Category 24  
Venting 24  
Venting Requirements 24  
Vent Length 25  
Vent Pipe 36  
Vent Pipe Joints 25  
Vent Pipe to Heater 25  
Vent Pipe Type 25  
Vent System Support 26  
Vent Terminal 26  
Vertical Dual Vent Terminal 29  
Vertical Vent 28  
Vertical Vent Terminal Arrangements 28

## W

Warnings 2  
Warranty 3  
Wiring Diagram 32

**INSTALLER MUST COMPLETE THE FOLLOWING:**

**Installer:**

Name \_\_\_\_\_  
Company \_\_\_\_\_  
Address \_\_\_\_\_  
\_\_\_\_\_  
\_\_\_\_\_  
Phone \_\_\_\_\_

**Distributor (company from which the unit was purchased):**

Contact \_\_\_\_\_  
Company \_\_\_\_\_  
Address \_\_\_\_\_  
\_\_\_\_\_  
\_\_\_\_\_  
Phone \_\_\_\_\_

Model No. \_\_\_\_\_ Serial No. \_\_\_\_\_ Date of Installation \_\_\_\_\_

SPECIFIC INSTALLATION NOTES: (i.e. Location, CFM, HP, Static Pressure, Amps, Gas Pressure, Temperature, Voltage, Adjustments, Warranty, etc.)

\_\_\_\_\_  
\_\_\_\_\_  
\_\_\_\_\_

**BUILDING OWNER OR MAINTENANCE PERSONNEL:**

For service or repair

- Contact the installer listed above.
- If you need additional assistance, contact the Distributor listed above.
- For more information, contact:

North America Web: [www.RezSpec.com](http://www.RezSpec.com); Call: 800-695-1901

Asia Web: [www.Reznor.cn](http://www.Reznor.cn)

Europe Web: [www.Reznor.eu](http://www.Reznor.eu)

**Reznor/Thomas & Betts**  
150 McKinley Avenue  
Mercer, PA 16137  
United States

**Gaz Industrie/Thomas & Betts**  
ZI de Rosarge - 230 Rue de la Dombes  
Les Echets - 01706 Miribel cedex  
France  
[gazindustrie@gazindustrie.fr](mailto:gazindustrie@gazindustrie.fr)

©2011 Thomas & Betts Corporation, All rights reserved.

**Trademark Notes:** Reznor® and SUPERSTRUT® are registered in at least the United States.

GAZ INDUSTRIE® is registered in at least France.

All other trademarks are the property of their respective owners.

5/11 Form I-VR (Version F.1)