



Air Conditioning & Heating

# GMVC95 & GCVC95/9

**COMFORTNET™-COMPATIBLE  
MULTI-POSITION, TWO-STAGE  
VARIABLE-SPEED GAS FURNACE**

**GMVC95: UP TO 95% AFUE  
GCVC95: UP TO 95% AFUE  
GCVC9: UP TO 93% AFUE**

**HEATING INPUT: 46,000–115,000 BTU/H**

## Standard Features

- Dual-diameter tubular heat exchanger
- Two-stage gas valve operates with two-stage or single-stage thermostats
- ComfortNet™ Communications System compatible
- Efficient and quiet variable-speed ECM circulator motor gently ramps up or down according to heating or cooling demand
- 120V Silicon Nitride igniter designed for long igniter life
- Furnace control board with self-diagnostics, color-coded low-voltage terminals, and provisions for electronic air cleaner and 120-volt or 24-volt humidifiers
- Low constant fan allows homeowner to activate very low speed to efficiently circulate air throughout the home. This setting costs as little as a 100-watt light bulb to operate.
- Dual-certified for sealed combustion direct vent (2-pipe) or non-direct vent (1-pipe) applications
- Quiet two-speed induced draft blower
- All models comply with California NOx emissions standards

## Cabinet Features

- Fully insulated, heavy-gauge steel cabinet with durable baked-enamel finish
- Foil-faced insulation lines the heat exchanger
- Easy-to-install top venting is standard; alternate flue/vent connections on some models
- Designed for multi-position installation –  
GMVC95: upflow, horizontal left or right;  
GCVC95/9: downflow, horizontal left or right
- Airtight solid bottom for side return applications and easy-cut tabs for effortless removal in bottom air inlet applications
- Convenient left or right connection for gas/electric service
- Coil and furnace fit flush for most installations



## Contents

Nomenclature.....	2
Product Specifications.....	3
Dimensions.....	4
Airflow Data.....	6
Wiring Diagrams.....	10
Thermostats.....	12
Accessories.....	12



\* Complete warranty details available from your local dealer or at [www.goodmanmfg.com](http://www.goodmanmfg.com). To receive the Lifetime Heat Exchanger Limited Warranty (good for as long as you own your home), 10-Year Unit Replacement Limited Warranty and 10-Year Parts Limited Warranty, online registration must be completed within 60 days of installation. Online registration is not required in California or Québec.



# NOMENCLATURE

	G	M	V	C	95	070	4	C	X	A	A	
	1	2	3	4	5,6	7,8,9	10	11	12	13	14	
<b>Brand</b>	G Goodman® Brand										<b>Revisions</b>	
											Major and minor revisions	
<b>Airflow Direction</b>	C Downflow/Horizontal D Dedicated Downflow H High Airflow K Dedicated Upflow M Upflow/Horizontal										<b>NOx</b>	
											N Natural Gas X Low NOx	
<b>Description/Motor</b>	V Two-Stage/Variable-speed H Two-Stage/Multi-speed S Single-Stage/Multi-speed E Two-Stage/High-Efficiency										<b>Cabinet Width</b>	
											A 14" B 17½" C 21" D 24½"	
<b>SystemType</b>	C ComfortNet™ Communicating System										<b>Maximum CFM @ 0.5" ESP</b>	
											3 1200      5 2000 4 1600	
<b>AFUE</b>	95 95%      8 80% 9 90%+										<b>MBTU/h</b>	
											045: 45,000      115: 115,000 070: 70,000      140: 140,000 090: 90,000	

**Important EnergyStar Notice:** EnergyStar ratings are dependent upon conditions beyond equipment installation. Proper sizing and installation of equipment is critical to achieve optimal performance. Split system air conditioners and heat pumps must be matched with appropriate coil components to meet EnergyStar criteria. Ask your contractor for details or visit [www.energystar.gov](http://www.energystar.gov).

**SPECIFICATIONS**

	GMVC95 0453BX	GMVC95 0704CX	GMVC95 0905CX	GMVC95 0905DX	GMVC95 1155DX	GVCV95 0714CX	GVCV95 0915DX	GVCV9 1155DX
<b>HEATING CAPACITY</b>								
High Fire Input <sup>1</sup>	46,000	69,000	92,000	92,000	115,000	69,000	92,000	115,000
High Fire Output <sup>1</sup>	45,000	67,000	90,000	90,000	109,000	65,000	87,000	109,000
Low Fire Input <sup>1</sup>	32,000	48,000	64,000	64,000	80,000	48,000	64,000	80,000
Low Fire Output <sup>1</sup>	30,800	46,400	61,700	61,700	77,400	45,000	60,100	77,400
AFUE <sup>2</sup>	95	95	95	95	95	95	95	93
Tons AC @ 0.5" ESP	1.5 - 3.0	1.5 - 4.0	2.0 - 5.0	2.0 - 5.0	2.0 - 5.0	1.5 - 4.0	2.0 - 5.0	2.0 - 5.0
Temperature Rise Range (°F)	30 - 60	30 - 60	30 - 60	30 - 60	30 - 60	25-55	25-55	40-70
<b>CIRCULATOR BLOWER</b>								
Size (D x W)	10" x 8"	10" x 10"	11" x 10"	11" x 10"	11" x 10"	10" x 10"	11" x 10"	11" x 10"
Horsepower @ 1050 RPM	½	¾	1	1	1	¾	1	1
Speed	Variable					Variable		
Vent Diameter <sup>3</sup>	2"	2"	3"	3"	3"	2"	3"	3"
No. of Burners	2	3	4	4	5	3	4	5
Disposable Filter (in <sup>2</sup> )	288	384	480	480	486	384	480	486
<b>ELECTRICAL DATA</b>								
Min. Circuit Ampacity (amps) <sup>4</sup>	11.3	14.1	14.4	14.4	14.4	11.2	15.0	14.4
Max. Overcurrent Protection <sup>5</sup>	15 amps	15 amps	15 amps	15 amps	15 amps	15 amps	15 amps	15 amps
<b>SHIP WEIGHT (LBS)</b>								
	121	145	160	160	170	139	165	160

<sup>1</sup> Natural Gas BTU/h

<sup>2</sup> DOE AFUE based upon Isolated Combustion System (ICS)

<sup>3</sup> Installer must supply one or two PVC pipes: one for combustion air (optional) and one for the flue outlet (required). Vent pipe must be either 2" or 3" in diameter, depending upon furnace input, number of elbows, length of run and installation (1 or 2 pipes). The optional Combustion Air Pipe is dependent on installation/code requirements and must be 2" or 3" diameter PVC.

<sup>4</sup> Minimum Circuit Ampacity = (1.25 x Circulator Blower Amps) + ID Blower amps. Wire size should be determined in accordance with National Electrical Codes. Extensive wire runs will require larger wire sizes.

<sup>5</sup> Maximum Overcurrent Protection Device refers to maximum recommended fuse or circuit breaker size. May use fuses or HACR-type circuit breakers of the same size as noted.

**NOTES**

- All furnaces are manufactured for use on 115 VAC, 60 Hz, single-phase electrical supply.
- Gas Service Connection ½" FPT
- Important: Size fuses and wires properly and make electrical connections in accordance with the National Electrical Code and/or all existing local codes.

# GMVC95 DIMENSIONS

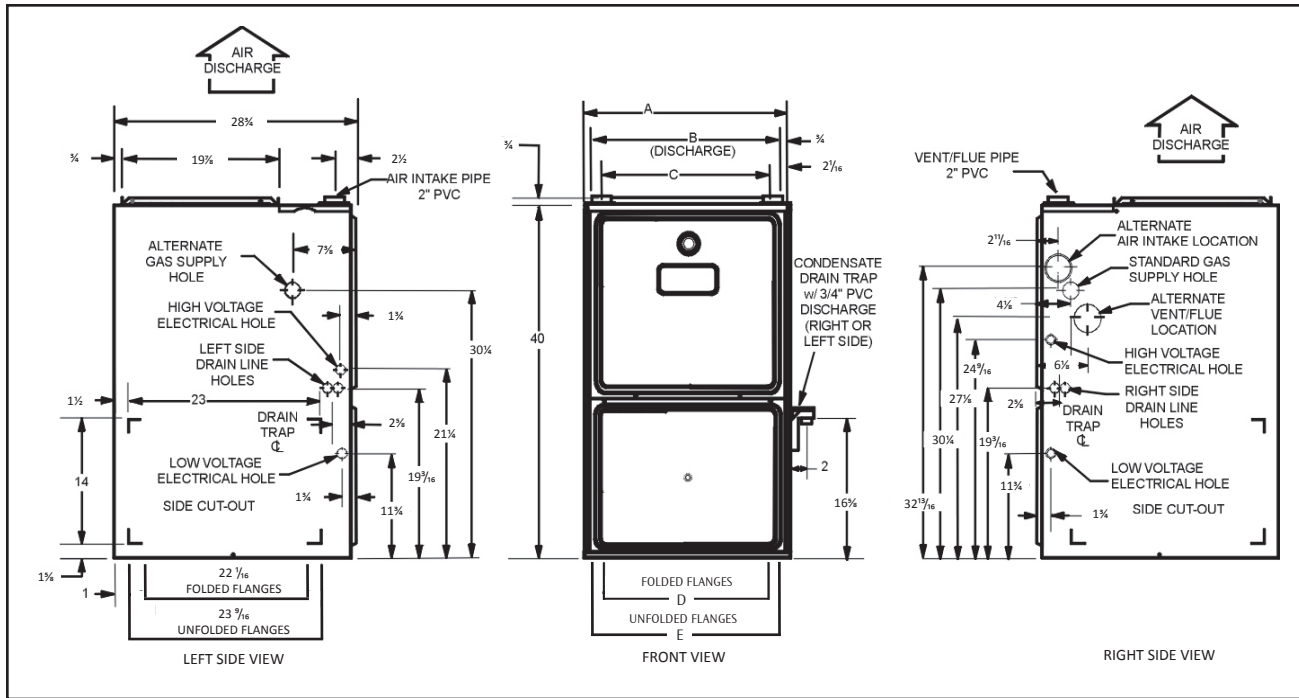

MODEL	A	B	C	D	E
GMVC950453BX	17½"	16"	13⅞"	12⅞"	13⅝"
GMVC950704CX	21"	19½"	16⅞"	16	17½"
GMVC950905CX	21"	19½"	16⅞"	16	17½"
GMVC950905DX	24½"	19½"	16⅞"	16	17½"
GMVC951155DX	24½"	23"	20⅞"	19⅞"	20⅞"

**NOTES:**

- Installer must supply one or two PVC pipes: one for combustion air (optional) and one for the flue outlet (required). Vent pipe must be either 2" or 3" in diameter, depending upon furnace input, number of elbows, length of run and installation (1 or 2 pipes). The optional Combustion Air Pipe is dependent on installation/code requirements and must be 2" or 3" diameter PVC.
- Line voltage wiring can enter through the right or left side of the furnace. Low-voltage wiring can enter through the right or left side of furnace.
- Conversion kits for high-altitude natural gas operation are available. Contact your Goodman distributor or dealer for details.
- Installer must supply following gas line fittings, according to which entrance is used:  
 Left—Two 90° elbows, one close nipple, straight pipe  
 Right—Straight pipe to reach gas valve
- For bottom return: Failure to unfold flanges may reduce airflow by up to 18%. This could result in performance and noise issues.

## MINIMUM CLEARANCES TO COMBUSTIBLE MATERIALS

POSITION	SIDES	REAR	FRONT	BOTTOM	FLUE	TOP
Upflow	0"	0"	3"	C	0"	1"
Horizontal	6"	0"	3"	C	0"	6"

C = If placed on combustible floor, the floor MUST be wood ONLY.

**NOTES:**

- For servicing or cleaning, a 24" front clearance is required.
- Unit connections (electrical, flue and drain) may necessitate greater clearances than the minimum clearances listed above.
- In all cases, accessibility clearance must take precedence over clearances from the enclosure where accessibility clearances are greater.

# GCVC95/9 DIMENSIONS

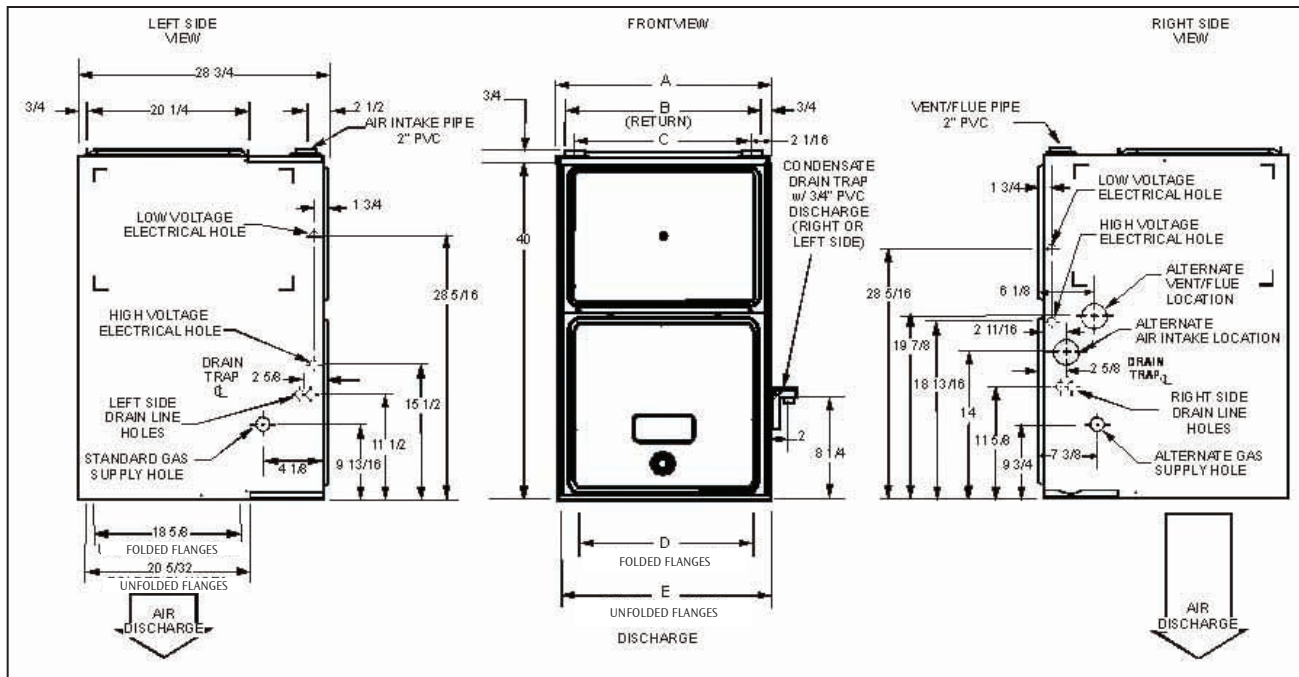

MODEL	A	B	C	D	E
GCVC950714CX	21"	19½"	16⅞"	18"	19½"
GCVC950915DX	24½"	23"	20⅞"	21½"	23"
GCVC91155DX	24½"	23"	20⅞"	21½"	23"

**NOTES:**

- Installer must supply one or two PVC pipes: one for combustion air (optional) and one for the flue outlet (required). Vent pipe must be either 2" or 3" in diameter, depending upon furnace input, number of elbows, length of run, and installation (1 or 2 pipes). The optional Combustion Air Pipe is dependent on installation/code requirements and must be 2" or 3" diameter PVC.
- Line voltage wiring can enter through the right or left side of the furnace. Low-voltage wiring can enter through the right or left side of furnace.
- Conversion kits for high-altitude natural gas operation are available. Contact your Goodman distributor or dealer for details.
- Installer must supply following gas line fittings, according to which entrance is used:  
 Left—Two 90° elbows, one close nipple, straight pipe  
 Right—Straight pipe to reach gas valve
- For bottom return: Failure to unfold flanges may reduce airflow by up to 18%. This could result in performance and noise issues.

## MINIMUM CLEARANCES TO COMBUSTIBLE MATERIALS

POSITION	SIDES	REAR	FRONT	BOTTOM	FLUE	TOP
Downflow	0"	0"	3"	NC	0"	1"
Horizontal	6"	0"	3"	C	0"	6"

C = If placed on combustible floor, the floor MUST be wood ONLY.

NC = For installation on non-combustible floors only. A combustible floor sub-base must be used for installations on combustible flooring.

**Notes:**

- For servicing or cleaning, a 24" front clearance is required.
- Unit connections (electrical, flue and drain) may necessitate greater clearances than the minimum clearances listed above.
- In all cases, accessibility clearance must take precedence over clearances from the enclosure where accessibility clearances are greater.

# GMVC95 AIRFLOW DATA

## COOLING SPEEDS

GMVC950453BX					
HIGH STAGE			LOW STAGE		
TAP	ADJUST	CFM*	TAP	ADJUST	CFM*
A	Minus(-)	540	A	Minus(-)	351
	Normal	600		Normal	390
	Plus (+)	660		Plus (+)	429
B	Minus(-)	720	B	Minus(-)	468
	Normal	800		Normal	520
	Plus (+)	880		Plus (+)	572
C	Minus(-)	900	C	Minus(-)	585
	Normal	1000		Normal	650
	Plus (+)	1100		Plus (+)	715
D	Minus(-)	1080	D	Minus(-)	702
	Normal	1200		Normal	780
	Plus (+)	1320		Plus (+)	858

GMVC950704CX					
HIGH STAGE			LOW STAGE		
TAP	ADJUST	CFM*	TAP	ADJUST	CFM*
A	Minus(-)	540	A	Minus(-)	351
	Normal	600		Normal	390
	Plus (+)	660		Plus (+)	429
B	Minus(-)	720	B	Minus(-)	468
	Normal	800		Normal	520
	Plus (+)	880		Plus (+)	572
C	Minus(-)	990	C	Minus(-)	644
	Normal	1100		Normal	715
	Plus (+)	1210		Plus (+)	787
D	Minus(-)	1286	D	Minus(-)	836
	Normal	1429		Normal	929
	Plus (+)	1572		Plus (+)	1022

GMVC950905CX					
HIGH STAGE			LOW STAGE		
TAP	ADJUST	CFM*	TAP	ADJUST	CFM*
A	Minus(-)	729	A	Minus(-)	495
	Normal	810		Normal	550
	Plus (+)	891		Plus (+)	605
B	Minus(-)	990	B	Minus(-)	693
	Normal	1100		Normal	770
	Plus (+)	1210		Plus (+)	847
C	Minus(-)	1323	C	Minus(-)	900
	Normal	1470		Normal	1000
	Plus (+)	1617		Plus (+)	1100
D	Minus(-)	1629	D	Minus(-)	1125
	Normal	1810		Normal	1250
	Plus (+)	1991		Plus (+)	1375

GMVC950905DX					
HIGH STAGE			LOW STAGE		
TAP	ADJUST	CFM*	TAP	ADJUST	CFM*
A	Minus(-)	720	A	Minus(-)	468
	Normal	800		Normal	520
	Plus (+)	880		Plus (+)	572
B	Minus(-)	900	B	Minus(-)	644
	Normal	1000		Normal	715
	Plus (+)	1100		Plus (+)	787
C	Minus(-)	1260	C	Minus(-)	819
	Normal	1400		Normal	910
	Plus (+)	1540		Plus (+)	1001
D	Minus(-)	1620	D	Minus(-)	1053
	Normal	1800		Normal	1170
	Plus (+)	1980		Plus (+)	1287

GMVC951155DX					
HIGH STAGE			LOW STAGE		
TAP	ADJUST	CFM*	TAP	ADJUST	CFM*
A	Minus(-)	720	A	Minus(-)	468
	Normal	800		Normal	520
	Plus (+)	880		Plus (+)	572
B	Minus(-)	990	B	Minus(-)	644
	Normal	1100		Normal	715
	Plus (+)	1210		Plus (+)	787
C	Minus(-)	1260	C	Minus(-)	819
	Normal	1400		Normal	910
	Plus (+)	1540		Plus (+)	1001
D	Minus(-)	1620	D	Minus(-)	1053
	Normal	1800		Normal	1170
	Plus (+)	1980		Plus (+)	1287

\* @ .1" - .8" w.c. ESP

**NOTES:**

- All furnaces ship as high speed for cooling. Installer must adjust blower speed as needed.
- For most jobs, about 400 CFM per ton when cooling is desirable.
- Do not operate above .5" w.c. ESP in heating mode. Operating CFM between .5" and .8" w.c. is tabulated for cooling purposes only.

# GMVC95 AIRFLOW DATA (CONT.)

## HEATING SPEEDS

GMVC950453BX (RISE RANGE: 30 - 60°F)				
TAP	ADJUST	LOW-STAGE CFM *	HIGH-STAGE CFM *	RISE (°F)
A	Minus(-)	495	713	57
	Normal	550	792	41
	Plus (+)	605	871	46
B	Minus(-)	540	778	52
	Normal	600	864	47
	Plus (+)	660	950	43
C	Minus(-)	585	842	48
	Normal	650	936	43
	Plus (+)	715	1,030	39
D	Minus(-)	630	907	45
	Normal	700	1,008	40
	Plus (+)	770	1,109	36

GMVC950704CX (RISE RANGE: 30 - 60°F)				
TAP	ADJUST	LOW-STAGE CFM *	HIGH-STAGE CFM *	RISE (°F)
A	Minus(-)	756	1,089	56
	Normal	840	1,210	50
	Plus (+)	924	1,331	46
B	Minus(-)	828	1,192	51
	Normal	920	1,325	46
	Plus (+)	1,012	1,457	42
C	Minus(-)	900	1,296	47
	Normal	1,000	1,440	42
	Plus (+)	1,100	1,584	38
D	Minus(-)	972	1,400	43
	Normal	1,080	1,555	39
	Plus (+)	1,188	1,711	35

GMVC950905CX (RISE RANGE: 30 - 60°F)				
TAP	ADJUST	LOW-STAGE CFM *	HIGH-STAGE CFM *	RISE (°F)
A	Minus(-)	945	1,341	60
	Normal	1,050	1,490	54
	Plus (+)	1,155	1,639	49
B	Minus(-)	1,008	1,413	57
	Normal	1,120	1,570	51
	Plus (+)	1,232	1,727	47
C	Minus(-)	1,080	1,521	53
	Normal	1,200	1,690	48
	Plus (+)	1,320	1,859	43
D	Minus(-)	1,125	1,602	50
	Normal	1,250	1,780	45
	Plus (+)	1,375	1,958	41

GMVC950905DX (RISE RANGE: 30 - 60°F)				
TAP	ADJUST	LOW-STAGE CFM *	HIGH-STAGE CFM *	RISE (°F)
A	Minus(-)	1,013	1,458	55
	Normal	1,125	1,620	50
	Plus (+)	1,238	1,782	45
B	Minus(-)	1,076	1,549	52
	Normal	1,195	1,721	47
	Plus (+)	1,315	1,893	43
C	Minus(-)	1,139	1,640	49
	Normal	1,265	1,822	44
	Plus (+)	1,392	2,004	40
D	Minus(-)	1,202	1,730	47
	Normal	1,335	1,922	42
	Plus (+)	1,469	2,114	38

GMVC951155DX (RISE RANGE: 35 - 65°F)				
TAP	ADJUST	LOW-STAGE CFM *	HIGH-STAGE CFM *	RISE (°F)
A	Minus(-)	1,107	1,594	63
	Normal	1,230	1,771	57
	Plus (+)	1,353	1,948	52
B	Minus(-)	1,139	1,639	62
	Normal	1,265	1,822	56
	Plus (+)	1,392	2,004	50
C	Minus(-)	1,170	1,685	60
	Normal	1,300	1,872	54
	Plus (+)	1,430	2,059	49
D	Minus(-)	1,202	1,730	58
	Normal	1,335	1,922	53
	Plus (+)	1,469	2,115	48

\* @ .1" - .5" w.c. ESP

**NOTES**

- All furnaces ship as high speed for cooling. Installer must adjust blower speed as needed.
- For most jobs, about 400 CFM per ton when cooling is desirable.
- Do not operate above .5" w.c. ESP in heating mode. Operating CFM between .5" and .8" w.c. is tabulated for cooling purposes only.

# GCVC95 AIRFLOW DATA

GCVC950714CX COOLING SPEEDS					
HIGH STAGE			LOW STAGE		
TAP	ADJUST	CFM*	TAP	ADJUST	CFM*
A	Minus	594	A	Minus	324
	Normal	660		Normal	360
	Plus	726		Plus	396
B	Minus	747	B	Minus	468
	Normal	830		Normal	520
	Plus	913		Plus	572
C	Minus	1017	C	Minus	702
	Normal	1130		Normal	780
	Plus	1243		Plus	858
D	Minus	1314	D	Minus	864
	Normal	1460		Normal	960
	Plus	1606		Plus	1056

GCVC950714CX HEATING SPEEDS (RISE RANGE: 25 - 55°F)							
HIGH STAGE				LOW STAGE			
TAP	ADJUST	CFM*	RISE	TAP	ADJUST	CFM*	RISE
A	Minus	1107	55	A	Minus	783	77
	Normal	1230	49		Normal	870	69
	Plus	1353	45		Plus	957	63
B	Minus	1215	50	B	Minus	855	71
	Normal	1350	45		Normal	950	64
	Plus	1485	41		Plus	1045	58
C	Minus	1323	46	C	Minus	936	65
	Normal	1470	41		Normal	1040	58
	Plus	1617	37		Plus	1144	53
D	Minus	1440	42	D	Minus	1017	59
	Normal	1600	38		Normal	1130	53
	Plus	1760	34		Plus	1243	49

\* @ .1" - .5" w.c. ESP

GCVC950915DX COOLING SPEEDS					
HIGH STAGE			LOW STAGE		
TAP	ADJUST	CFM*	TAP	ADJUST	CFM*
A	Minus	729	A	Minus	504
	Normal	810		Normal	560
	Plus	891		Plus	616
B	Minus	999	B	Minus	666
	Normal	1110		Normal	740
	Plus	1221		Plus	814
C	Minus	1287	C	Minus	828
	Normal	1430		Normal	920
	Plus	1573		Plus	1012
D	Minus	1674	D	Minus	1071
	Normal	1860		Normal	1190
	Plus	2046		Plus	1309

GCVC950915DX HEATING SPEEDS (RISE RANGE: 25 - 55°F)							
HIGH STAGE				LOW STAGE			
TAP	ADJUST	CFM*	RISE	TAP	ADJUST	CFM*	RISE
A	Minus	1458	55	A	Minus	1008	80
	Normal	1620	50		Normal	1120	72
	Plus	1782	45		Plus	1232	65
B	Minus	1575	51	B	Minus	1098	73
	Normal	1750	46		Normal	1220	66
	Plus	1925	42		Plus	1342	60
C	Minus	1674	48	C	Minus	1152	70
	Normal	1860	43		Normal	1280	63
	Plus	2046	39		Plus	1408	57
D	Minus	1773	45	D	Minus	1206	67
	Normal	1970	41		Normal	1340	60
	Plus	2167	37		Plus	1474	55

\* @ .1" - .5" w.c. ESP

**NOTES**

- All furnaces ship as high speed for cooling. Installer must adjust blower speed as needed.
- For most jobs, about 400 CFM per ton when cooling is desirable.
- Do not operate above .5" w.c. ESP in heating mode. Operating CFM between .5" and .8" w.c. is tabulated for cooling purposes only.

## GCVC9 AIRFLOW DATA

GCVC91155DX COOLING SPEEDS					
HIGH STAGE			LOW STAGE		
TAP	ADJUST	CFM*	TAP	ADJUST	CFM*
A	Minus(-)	705	A	Minus(-)	457
	Normal	783		Normal	508
	Plus (+)	861		Plus (+)	559
B	Minus(-)	982	B	Minus(-)	621
	Normal	1091		Normal	690
	Plus (+)	1200		Plus (+)	759
C	Minus(-)	1265	C	Minus(-)	815
	Normal	1406		Normal	906
	Plus (+)	1547		Plus (+)	997
D	Minus(-)	1628	D	Minus(-)	1049
	Normal	1809		Normal	1165
	Plus (+)	1990		Plus (+)	1282

GCVC91155DX HEATING SPEEDS (RISE RANGE: 40 - 70°F)							
HIGH STAGE				LOW STAGE			
TAP	ADJUST	CFM*	RISE	TAP	ADJUST	CFM*	RISE
A	Minus(-)	1583	63	A	Minus(-)	1093	63
	Normal	1759	56		Normal	1214	56
	Plus (+)	1935	51		Plus (+)	1335	51
B	Minus(-)	1612	61	B	Minus(-)	1106	61
	Normal	1791	55		Normal	1229	55
	Plus (+)	1970	50		Plus (+)	1352	50
C	Minus(-)	1654	60	C	Minus(-)	1166	60
	Normal	1838	54		Normal	1296	54
	Plus (+)	2022	49		Plus (+)	1426	49
D	Minus(-)	1690	59	D	Minus(-)	1172	59
	Normal	1878	53		Normal	1302	53
	Plus (+)	2066	48		Plus (+)	1432	48

\* @ .1" - .5" w.c. ESP

### NOTES

- All furnaces ship as high speed for cooling. Installer must adjust blower speed as needed.
- For most jobs, about 400 CFM per ton when cooling is desirable.
- Do not operate above .5" w.c. ESP in heating mode. Operating CFM between .5" and .8" w.c. is tabulated for cooling purposes only.

CONTINUOUS FAN SPEEDS		
MODEL	MAXIMUM CFM	CONTINUOUS FAN SPEED <sup>1</sup>
GMVC950453BX	1400	420
GMVC950704CX	1760	530
GMVC950905CX	2200	660
GMVC950905DX	2200	660
GMVC951155DX	2200	660
GCVC950704CX	1760	530
GCVC950905DX	2200	660
GCVC91155DX	2200	660

<sup>1</sup> Continuous fan speed is 30% of furnace maximum CFM

## STANDARD ALTITUDE INSTALLATIONS

GAS	ALTITUDE	KIT	ORIFICE	MANIFOLD PRESSURE		PRESSURE SWITCH CHANGE
				HIGH STAGE	LOW STAGE	
Natural	0-7000 Changeover	None	#43	3.5" W.C.	1.9" W.C.	None
Propane	0-7000	LPM-03B & LPM-05	#55	10.0" W.C.	6.0" W.C.	None

- For installation in Canada, gas furnaces are certified only to 4,500 ft.
- For GCVA installations above 7,000 ft., please refer to your Goodman distributor for required kit(s).

# GMVC95/GCVC95/9 WIRING DIAGRAM WITH HONEYWELL VALVE

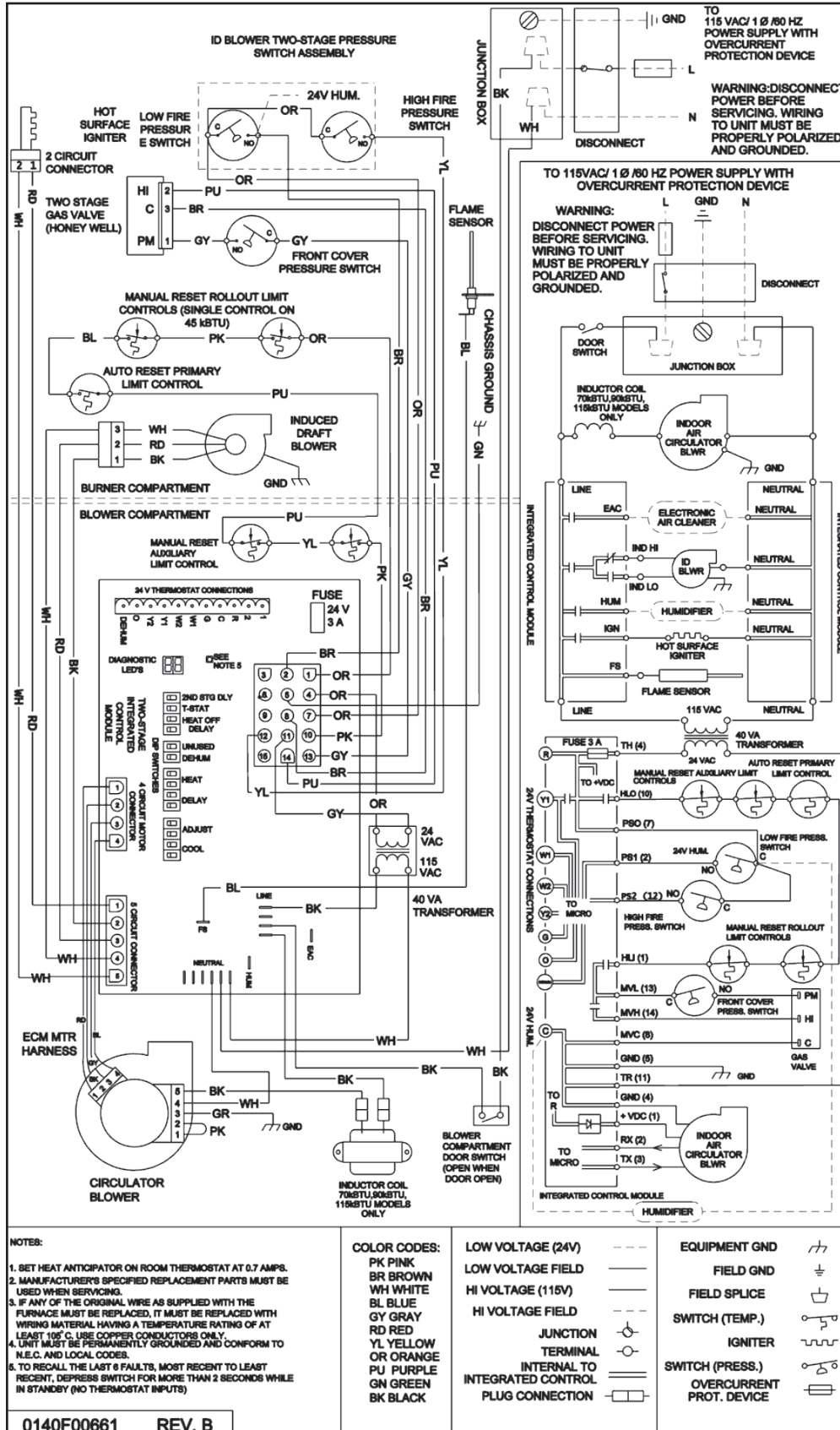

**WARNING**

High Voltage: Disconnect all power before servicing or installing this unit. Multiple power sources may be present. Failure to do so may cause property damage, personal injury, or death.

Wiring is subject to change. Always refer to the wiring diagram or the unit for the most up-to-date wiring.

# GMVC95/GCVC9 WIRING DIAGRAM WITH WHITE-RODGERS VALVE

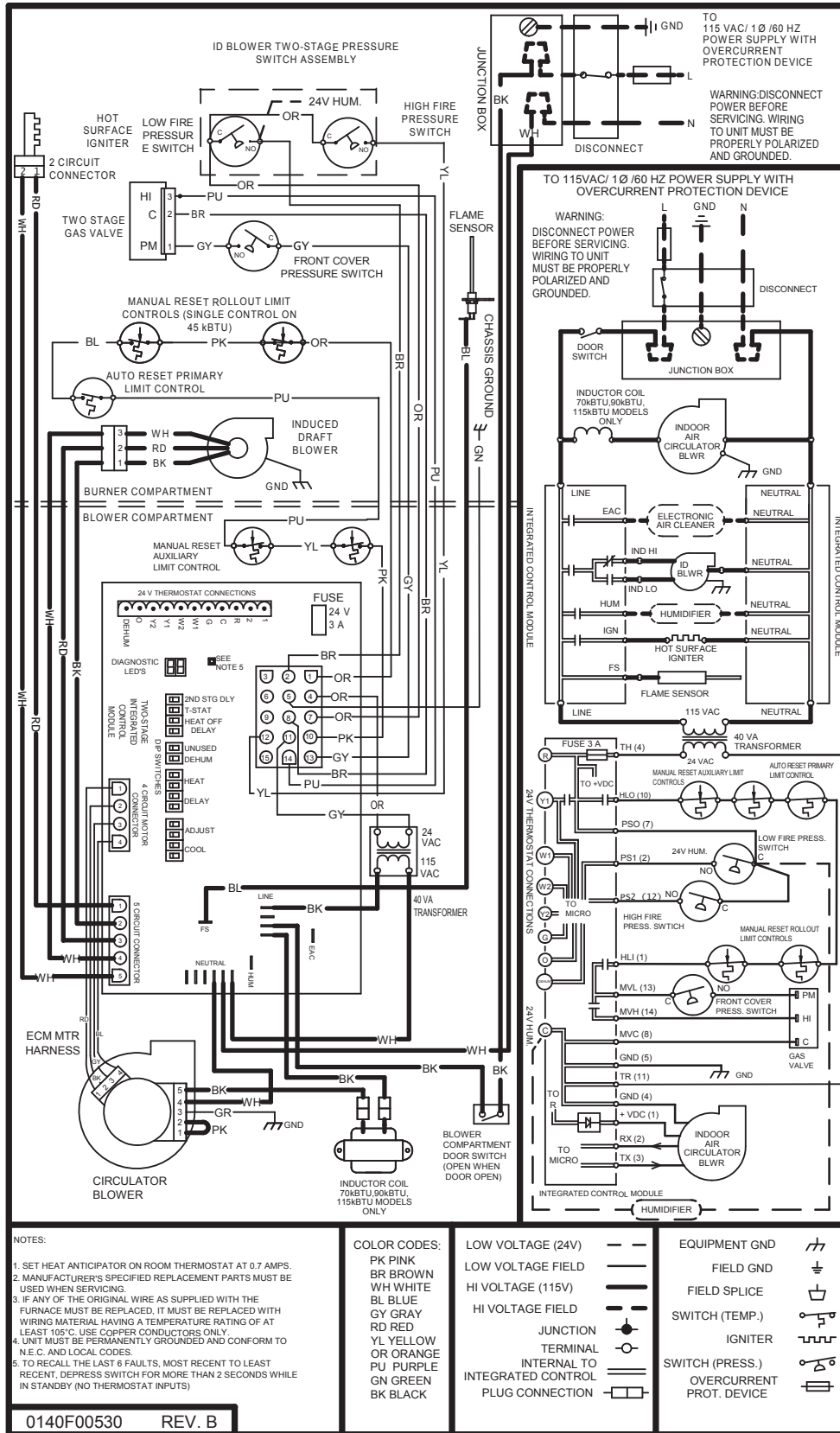

**High Voltage:** Disconnect all power before servicing or installing this unit. Multiple power sources may be present. Failure to do so may cause property damage, personal injury, or death.

**WARNING**

Wiring is subject to change. Always refer to the wiring diagram or the unit for the most up-to-date wiring.

# THERMOSTATS

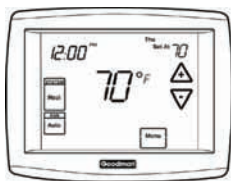

GTS1175-2  
GTS3275-2  
GTS 4275-2

Touch-Screen Digital Thermostats  
(See Amana Thermostat specification sheets for details.)

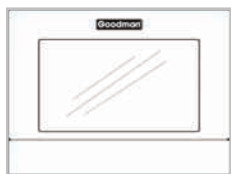

G2111-2  
G3272-2  
G3273-2

Touch-Screen Digital Thermostats  
(See Amana Thermostat specification sheets for details.)

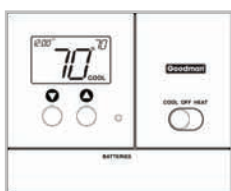

G1100-2  
G2100-2  
G1152-2  
G2152-2

Programmable and Non-programmable Digital Thermostats  
(See Amana Thermostat specification sheets for details.)

# ACCESSORIES

MODEL	DESCRIPTION	GMVC95 0453BX	GMVC95 0704CX	GMVC95 0905C/DX	GMVC95 1155DX	GCVC95 0704CX	GCVC95 0905DX	GCVC9 1155DX
LPM-05	LP Conversion Kit * (Springs & Orifice)	1	1	1	1	1	1	1
LPM-06	LP Conversion Kit ** (Springs & Orifice)	1	1	1	1	1	1	1
GSAS	Electronic Air Cleaners (-10, -11, -12 or -18)	√	√	√	√	√	√	√
GMU	Media Air Cleaners (1620, 2020, 1625 or 2025)	√	√	√	√	√	√	√
DEHUM1	Dehumidistat	√	√	√	√	√	√	√
HAPS28	High-Altitude Pressure Switch Kit	2	2					
HAPS29	High-Altitude Pressure Switch Kit				2			
HAPS 31	High-Altitude Pressure Switch Kit							2
HALP11	High-Altitude Propane Gas Kit	2	2		2			
HALP 13	High-Altitude Propane Gas Kit							2
HANG 13	High-Altitude Natural Gas Kit	3	3		3			
HANG 14	High-Altitude Natural Gas Kit	4	4		4			
HANG 16	High-Altitude Natural Gas Kit							2
EFR01	External Filter Rack	√	√	√	√	√	√	√
DCVK-20	Horizontal/Vertical Concentric Vent Kit (2")	√	√	√		√		
DCVK-30	Horizontal/Vertical Concentric Vent Kit (3")	√	√	√	√	√	√	√
CFB21	Downflow Floor Base					√		
CFB24	Downflow Floor Base						√	√
017K00000S	Flush-mount vent kit	√	√	√	√	√	√	√

\* White-Rodgers gas valve                      \*\* Honeywell or White-Rodgers gas valve  
 1 All Models up to 7,000'                      2 7,001' to 11,000'  
 3 7,001' to 9,000'                                  4 9,001' to 11,000'

**Note:** All installations above 7,000' require a pressure switch change. For installation in Canada, gas furnaces are certified only to 4,500'.

