



ASZ14

SPLIT SYSTEM HEAT PUMP

UP TO 14 SEER

R-410A

COOLING CAPACITY: 18,000 - 60,000 BTU/H

HEATING CAPACITY: 18,000 - 59,000 BTU/H

Standard Features

- R-410A chlorine-free refrigerant
- High-efficiency scroll compressor
- High density foam compressor sound blanket
- SmartShift™ technology to ensure quiet reliable defrost
- Factory-installed bi-flow liquid line filter dryer
- Factory-installed suction line accumulator
- Factory-installed compressor crank case heater
- Factory-installed high capacity muffler
- High- and low-pressure switches
- Service valves with sweat connections and easy access to gauge ports
- Copper tube/enhanced aluminum fin coil
- Fully charged for 15' of tubing length
- Contactor with lug connection
- Ground lug connection
- AHRI Certified; ETL Listed

Cabinet Features

- Amana® brand sound control top design
- Wire fan discharge grille
- Steel louver coil guard
- Baked-on powder-paint finish
- Rust-resistant screws
- Compact footprint
- Top and side maintenance access
- Single-panel access to controls with space provided for field-installed accessories
- When properly anchored, meets the 2001 Florida Building Code unit integrity requirements for hurricane-type winds (Anchor bracket kits available.)



Contents

Nomenclature	2
Product Specifications	3
Expanded Cooling Data	4
Expanded Heating Data	20
AHRI Ratings	22
Dimensions	34
Wiring Diagram	35
Accessories	36



* Complete warranty details available from your local dealer or at www.amana-hac.com. To receive the Lifetime Unit Replacement Limited Warranty (good for as long as you own your home) and 10-Year Parts Limited Warranty, online registration must be completed within 60 days of installation. Online registration is not required in California or Québec.

NOMENCLATURE

	A	S	Z	14	036	1	AA	
	1	2	3	4,5	6,7,8	9	10,11	
Brand	A Amana® Brand							Engineering * Major/ Minor Revisions * Neither revision is used for order entry or inventory management.
Product Category	S Split System							
Unit Type	C Condenser R-22 X Condenser R-410A H Heat Pump R-22 Z Heat Pump R-410A							Electrical 1 208/230 V, 1 Phase, 60 Hz 2 220/240 V, 1 Phase, 50 Hz 3 208/230 V, 3 Phase, 60 Hz 4 460 V, 3 Phase, 60 Hz 5 380/415 V, 3 Phase, 50 Hz
Efficiency	13 13 SEER 14 14 SEER 16 16 SEER 18 18 SEER							Nominal Capacity 018 1½ Tons 048 4 Tons 024 2 Tons 060 5 Tons 030 2½ Tons 090 7½ tons 036 3 Tons 120 10 Tons 042 3½ Tons



Important EnergyStar Notice: EnergyStar ratings are dependent upon conditions beyond equipment installation. Proper sizing and installation of equipment is critical to achieve optimal performance. Split system air conditioners and heat pumps must be matched with appropriate coil components to meet EnergyStar criteria. Ask your contractor for details or visit www.energystar.gov.

SPECIFICATIONS

	ASZ14 0181A	ASZ14 0241A	ASZ14 0301A	ASZ14 0361A	ASZ14 0361B	ASZ14 0421A	ASZ14 0481A	ASZ14 0601A
CAPACITIES AND RATINGS								
Nominal Cooling (BTU/h)	18,000	24,000	30,000	36,000	35,000	42,000	48,000	60,000
Nominal Heating (BTU/h)	18,000	24,000	28,000	36,000	33,000	42,000	46,600	59,000
Decibels	70	72	72	73	74	73	74	75
COMPRESSOR								
RLA	9.0	12.8	14.1	16.7	14.1	17.9	19.9	26.4
LRA	48.0	58.3	73.0	79.0	77.0	112.0	109.0	134.0
CONDENSER FAN MOTOR								
Horsepower	1/12	1/6	1/6	¼	1/4	¼	¼	¼
FLA	0.6	0.9	1.10	1.5	1.5	1.5	1.5	1.5
LRA	1.0	1.5	1.9	3.1	3.1	3.1	3.1	3.1
REFRIGERATION SYSTEM								
Refrigerant Line Size ¹								
Liquid Line Size ("O.D.)	⅜"	⅜"	⅜"	⅜"	3/8"	⅜"	⅜"	⅜"
Suction Line Size ("O.D.)	¼"	¼"	¼"	⅝"	7/8"	1⅝"	1⅝"	1⅝"
Refrigerant Connection Size								
Liquid Valve Size ("O.D.)	⅜"	⅜"	⅜"	⅜"	3/8"	⅜"	⅜"	⅜"
Suction Valve Size ("O.D.)	¼"	¼"	¼"	⅝"	3/4"	⅝"	⅝"	⅝"
Valve Connection Type	Sweat	Sweat	Sweat	Sweat	Sweat	Sweat	Sweat	Sweat
Refrigerant Charge	140	160	185	210	186	210	270	275
ELECTRICAL DATA								
Volts / Hz / Phase	208/230-60-1		208/230-60-1		208/230-60-1		208/230-60-1	
Minimum Circuit Ampacity ²	11.9	16.9	18.7	22.4	19.1	23.9	26.4	34.5
Max. Overcurrent Protection ³	20	25	30	30	30	40	40	60
Min / Max Volts	197 / 253	197 / 253	197 / 253	197 / 253	197/253	197 / 253	197 / 253	197 / 253
Electrical Conduit Size	½" or ¾"	½" or ¾"	½" or ¾"	½" or ¾"	½" or ¾"	½" or ¾"	½" or ¾"	½" or ¾"
Low Voltage	½"	½"	½"	½"	½"	½"	½"	½"
SHIP WEIGHT (LBS)	199	207	219	242	215	242	266	280

¹ Tested and rated in accordance with AHRI Standard 210/240

² Wire size should be determined in accordance with National Electrical Codes; extensive wire runs will require larger wire sizes

³ Must use time-delay fuses or HACR-type circuit breakers of the same size as noted.

NOTES

- Always check the S&R plate for electrical data on the unit being installed.
- Installer will need to supply ⅝" to 1⅝" adapters for suction line connections.
- Unit is charged with refrigerant for 15' of ⅜" liquid line. System charge must be adjusted per Installation Instructions Final Charge Procedure.
- Installation of these units requires the specified TXV Kit to be installed on the indoor coil. THE SPECIFIED TXV IS DETERMINED BY THE OUTDOOR UNIT NOT THE INDOOR COIL.

EXPANDED COOLING DATA — ASZ140181A* / CA*F3131*6A* +TXV / MBR800**-1

IDB	AIRFLOW	OUTDOOR AMBIENT TEMPERATURE												ENTERING INDOOR WET BULB TEMPERATURE											
		65°F				75°F				85°F				95°F				105°F				115°F			
		59	63	67	71	59	63	67	71	59	63	67	71	59	63	67	71	59	63	67	71	59	63	67	71
70	MBh	17.6	18.3	20.0	-	17.2	17.9	19.6	-	16.8	17.4	19.1	-	16.4	17.0	18.6	-	15.6	16.2	17.7	-	14.4	15.0	16.4	-
	S/T	0.74	0.62	0.43	-	0.76	0.64	0.44	-	0.78	0.65	0.45	-	0.81	0.67	0.47	-	0.84	0.70	0.49	-	0.85	0.71	0.49	-
	ΔT	18	15	12	-	18	16	12	-	18	16	12	-	18	16	12	-	18	15	12	-	17	14	11	-
	kW	1.17	1.19	1.23	-	1.25	1.28	1.32	-	1.33	1.36	1.40	-	1.40	1.43	1.47	-	1.45	1.48	1.53	-	1.50	1.53	1.58	-
	Amps	4.2	4.3	4.4	-	4.5	4.6	4.8	-	4.9	5.0	5.2	-	5.3	5.4	5.6	-	5.6	5.7	5.9	-	5.9	6.1	6.3	-
	Hi PR	213	229	242	-	239	257	271	-	271	292	308	-	309	333	351	-	348	374	395	-	384	413	436	-
	Lo PR	107	113	124	-	113	120	131	-	117	124	136	-	123	131	143	-	129	137	150	-	133	142	155	-
	MBh	17.1	17.7	19.4	-	16.7	17.3	19.0	-	16.3	16.9	18.5	-	15.9	16.5	18.1	-	15.1	15.7	17.2	-	14.0	14.5	15.9	-
	S/T	0.70	0.59	0.41	-	0.73	0.61	0.42	-	0.75	0.62	0.43	-	0.77	0.64	0.45	-	0.80	0.67	0.46	-	0.81	0.67	0.47	-
	ΔT	18	16	12	-	19	16	12	-	19	16	12	-	19	16	12	-	19	16	12	-	17	15	11	-
525	kW	1.16	1.18	1.22	-	1.24	1.27	1.31	-	1.32	1.35	1.39	-	1.38	1.41	1.46	-	1.44	1.47	1.52	-	1.49	1.52	1.57	-
	Amps	4.2	4.3	4.4	-	4.5	4.6	4.8	-	4.9	5.0	5.2	-	5.2	5.3	5.5	-	5.5	5.7	5.9	-	5.9	6.0	6.2	-
	Hi PR	210	227	239	-	236	254	268	-	269	289	305	-	306	329	348	-	344	370	391	-	380	409	432	-
	Lo PR	105	112	122	-	111	119	129	-	116	123	134	-	122	129	141	-	127	136	148	-	132	140	153	-
	MBh	15.8	16.4	17.9	-	15.4	16.0	17.5	-	15.1	15.6	17.1	-	14.7	15.2	16.7	-	14.0	14.5	15.9	-	12.9	13.4	14.7	-
	S/T	0.68	0.57	0.39	-	0.70	0.59	0.41	-	0.72	0.60	0.42	-	0.74	0.62	0.43	-	0.77	0.64	0.45	-	0.78	0.65	0.45	-
	ΔT	19	16	12	-	19	16	12	-	19	16	12	-	19	17	13	-	19	16	12	-	18	15	12	-
	kW	1.13	1.15	1.19	-	1.21	1.24	1.28	-	1.29	1.31	1.35	-	1.35	1.38	1.42	-	1.41	1.44	1.48	-	1.45	1.48	1.53	-
	Amps	4.1	4.2	4.3	-	4.4	4.5	4.6	-	4.7	4.9	5.0	-	5.1	5.2	5.4	-	5.4	5.5	5.7	-	5.7	5.8	6.0	-
	Hi PR	204	220	232	-	229	247	260	-	261	280	296	-	297	319	337	-	334	359	379	-	369	397	419	-
Lo PR	102	109	119	-	108	115	126	-	112	119	130	-	118	126	137	-	124	132	144	-	128	136	149	-	

75	MBh	17.9	18.5	20.0	21.5	17.5	18.0	19.5	21.0	17.1	17.6	19.1	20.5	16.7	17.2	18.6	20.0	15.9	16.3	17.7	19.0	14.7	15.1	16.4	17.6
	S/T	0.84	0.75	0.57	0.36	0.87	0.78	0.59	0.38	0.89	0.80	0.60	0.39	0.92	0.82	0.62	0.40	0.95	0.85	0.65	0.42	0.96	0.86	0.65	0.42
	ΔT	20	19	15	11	21	19	16	11	21	19	16	11	21	19	16	11	21	19	16	11	19	18	15	10
	kW	1.18	1.20	1.24	1.27	1.26	1.29	1.33	1.37	1.34	1.37	1.41	1.46	1.41	1.44	1.48	1.53	1.46	1.50	1.54	1.59	1.51	1.55	1.60	1.65
	Amps	4.2	4.3	4.5	4.6	4.6	4.7	4.8	5.0	5.0	5.1	5.2	5.4	5.3	5.4	5.6	5.8	5.6	5.8	6.0	6.2	6.0	6.1	6.3	6.5
	Hi PR	215	231	244	255	241	259	274	286	274	295	311	325	312	336	355	370	351	378	399	416	388	418	441	460
	Lo PR	108	114	125	133	114	121	132	141	118	126	137	146	124	132	144	154	130	138	151	161	135	143	156	166
	MBh	17.4	17.9	19.4	20.8	17.0	17.5	19.0	20.3	16.6	17.1	18.5	19.9	16.2	16.7	18.1	19.4	15.4	15.8	17.2	18.4	14.3	14.7	15.9	17.1
	S/T	0.80	0.71	0.54	0.35	0.83	0.74	0.56	0.36	0.85	0.76	0.57	0.37	0.88	0.78	0.59	0.38	0.91	0.81	0.62	0.40	0.92	0.82	0.62	0.40
	ΔT	21	20	16	11	22	20	16	11	22	20	16	11	22	20	16	11	21	20	16	11	20	18	15	10
525	kW	1.17	1.19	1.23	1.26	1.25	1.28	1.32	1.36	1.33	1.36	1.40	1.44	1.40	1.43	1.47	1.52	1.45	1.48	1.53	1.58	1.50	1.53	1.58	1.64
	Amps	4.2	4.3	4.4	4.6	4.5	4.6	4.8	5.0	4.9	5.0	5.2	5.4	5.3	5.4	5.6	5.8	5.6	5.7	5.9	6.1	5.9	6.1	6.3	6.5
	Hi PR	213	229	242	252	239	257	271	283	271	292	308	322	309	333	351	366	348	374	395	412	384	413	437	455
	Lo PR	107	113	124	132	113	120	131	139	117	124	136	145	123	131	143	152	129	137	150	159	133	142	155	165
	MBh	16.1	16.5	17.9	19.2	15.7	16.2	17.5	18.8	15.3	15.8	17.1	18.3	15.0	15.4	16.7	17.9	14.2	14.6	15.8	17.0	13.2	13.5	14.7	15.7
	S/T	0.77	0.69	0.52	0.34	0.80	0.71	0.54	0.35	0.82	0.73	0.55	0.36	0.84	0.76	0.57	0.37	0.88	0.78	0.59	0.38	0.88	0.79	0.60	0.39
	ΔT	22	20	16	11	22	20	17	11	22	20	17	11	22	20	17	12	22	20	16	11	20	19	15	11
	kW	1.14	1.16	1.20	1.24	1.22	1.25	1.29	1.33	1.30	1.32	1.37	1.41	1.36	1.39	1.44	1.48	1.42	1.45	1.49	1.54	1.47	1.50	1.54	1.60
	Amps	4.1	4.2	4.3	4.5	4.4	4.5	4.7	4.8	4.8	4.9	5.1	5.2	5.1	5.2	5.4	5.6	5.4	5.6	5.7	6.0	5.7	5.9	6.1	6.3
	Hi PR	206	222	234	244	231	249	263	274	263	283	299	312	300	323	341	355	337	363	383	400	373	401	423	442
Lo PR	103	110	120	128	109	116	127	135	113	121	132	140	119	127	138	147	125	133	145	155	129	137	150	160	

IDB: Entering Indoor Dry Bulb Temperature Shaded area reflects ACCA (TVA) conditions kW=Total system power Amps = outdoor unit amps (comp. + fan)

EXPANDED COOLING DATA — SZ140181A* / CA*F3131*6A* +TXV / MBR800** -1 (CONT.)

IDB	OUTDOOR AMBIENT TEMPERATURE												ENTERING INDOOR WET BULB TEMPERATURE												
	65°F				75°F				85°F				95°F				105°F				115°F				
	59	63	67	71	59	63	67	71	59	63	67	71	59	63	67	71	59	63	67	71	59	63	67	71	
80	MBh	18.3	18.7	19.9	21.3	17.8	18.2	19.5	20.8	17.4	17.8	19.0	20.3	17.0	17.4	18.5	19.8	16.1	16.5	17.6	18.8	14.9	15.3	16.3	17.4
	S/T	0.92	0.86	0.70	0.52	0.95	0.89	0.73	0.54	1.00	0.92	0.75	0.56	1.00	0.94	0.77	0.57	1.00	1.00	0.80	0.60	1.00	1.00	0.80	0.60
	ΔT	23	22	19	15	23	22	19	15	23	22	19	15	23	22	19	16	22	21	19	15	20	21	18	14
	kW	1.19	1.21	1.25	1.28	1.27	1.30	1.34	1.38	1.35	1.38	1.42	1.47	1.42	1.45	1.50	1.54	1.48	1.51	1.56	1.61	1.53	1.56	1.61	1.66
	Amps	4.3	4.4	4.5	4.7	4.6	4.7	4.9	5.1	5.0	5.1	5.3	5.5	5.3	5.5	5.7	5.9	5.7	5.8	6.0	6.2	6.0	6.2	6.4	6.6
	Hi PR	217	233	247	257	243	262	277	288	277	298	315	328	315	339	358	374	355	382	403	420	392	422	445	465
	Lo PR	109	116	126	134	115	122	133	142	119	127	139	148	125	133	146	155	131	140	153	162	136	145	158	168
	MBh	17.7	18.1	19.4	20.7	17.3	17.7	18.9	20.2	16.9	17.3	18.5	19.7	16.5	16.8	18.0	19.2	15.7	16.0	17.1	18.3	14.5	14.8	15.8	16.9
	S/T	0.88	0.82	0.67	0.50	0.91	0.85	0.69	0.52	0.93	0.87	0.71	0.53	0.96	0.90	0.73	0.55	1.00	0.94	0.76	0.57	1.00	0.94	0.77	0.57
	ΔT	24	23	20	16	24	23	20	16	24	23	20	16	24	23	20	16	24	23	20	16	22	21	19	15
kW	1.18	1.20	1.24	1.27	1.26	1.29	1.33	1.37	1.34	1.37	1.41	1.46	1.41	1.44	1.48	1.53	1.46	1.50	1.54	1.59	1.51	1.55	1.60	1.65	
Amps	4.2	4.3	4.5	4.6	4.6	4.7	4.8	5.0	5.0	5.1	5.3	5.4	5.3	5.4	5.6	5.8	5.6	5.8	6.0	6.2	6.0	6.1	6.3	6.5	
Hi PR	215	231	244	255	241	259	274	286	274	295	311	325	312	336	355	370	351	378	399	416	388	418	441	460	
Lo PR	108	114	125	133	114	121	132	141	118	126	137	146	124	132	144	154	130	138	151	161	135	143	156	166	
MBh	16.4	16.7	17.9	19.1	16.0	16.3	17.4	18.6	15.6	15.9	17.0	18.2	15.2	15.6	16.6	17.8	14.5	14.8	15.8	16.9	13.4	13.7	14.6	15.6	
S/T	0.84	0.79	0.64	0.48	0.88	0.82	0.67	0.50	0.90	0.84	0.69	0.51	0.93	0.87	0.71	0.53	0.96	0.90	0.73	0.55	0.97	0.91	0.74	0.55	
ΔT	24	23	20	16	24	23	20	16	25	24	21	16	25	24	21	16	24	23	20	16	23	22	19	15	
kW	1.15	1.17	1.21	1.24	1.23	1.26	1.30	1.34	1.31	1.34	1.38	1.42	1.37	1.40	1.45	1.49	1.43	1.46	1.51	1.56	1.48	1.51	1.56	1.61	
Amps	4.1	4.2	4.4	4.5	4.5	4.6	4.7	4.9	4.8	4.9	5.1	5.3	5.2	5.3	5.5	5.7	5.5	5.6	5.8	6.0	5.8	5.9	6.1	6.4	
Hi PR	208	224	237	247	234	252	266	277	266	286	302	315	303	326	344	359	341	367	387	404	376	405	428	446	
Lo PR	104	111	121	129	110	117	128	136	115	122	133	142	120	128	140	149	126	134	147	156	131	139	152	161	

85	MBh	18.6	18.9	19.8	21.2	18.1	18.5	19.4	20.7	17.7	18.1	18.9	20.2	17.3	17.6	18.4	19.7	16.4	16.7	17.5	18.7	15.2	15.5	16.2	17.3
	S/T	0.96	0.93	0.84	0.68	1.00	0.96	0.87	0.71	1.00	0.99	0.89	0.72	1.00	1.00	0.92	0.75	1.00	1.00	0.95	0.77	1.00	1.00	0.96	0.78
	ΔT	24	24	23	20	25	24	23	20	24	24	23	20	24	24	23	20	22	23	23	20	21	21	21	18
	kW	1.19	1.22	1.26	1.29	1.28	1.31	1.35	1.39	1.36	1.39	1.43	1.48	1.43	1.46	1.51	1.56	1.49	1.52	1.57	1.62	1.54	1.57	1.62	1.68
	Amps	4.3	4.4	4.6	4.7	4.7	4.8	4.9	5.1	5.1	5.2	5.3	5.5	5.4	5.5	5.7	5.9	5.7	5.9	6.1	6.3	6.1	6.2	6.4	6.7
	Hi PR	219	236	249	260	246	265	279	291	280	301	318	331	318	343	362	377	358	386	407	425	396	426	450	469
	Lo PR	110	117	127	136	116	123	135	143	121	128	140	149	127	135	147	157	133	141	154	164	137	146	159	170
	MBh	18.0	18.4	19.3	20.5	17.6	18.0	18.8	20.1	17.2	17.5	18.4	19.6	16.8	17.1	17.9	19.1	15.9	16.2	17.0	18.2	14.8	15.0	15.8	16.8
	S/T	0.92	0.89	0.80	0.65	0.95	0.92	0.83	0.67	0.98	0.94	0.85	0.69	1.00	0.97	0.88	0.71	1.00	1.00	0.91	0.74	1.00	1.00	0.92	0.74
	ΔT	25	25	24	20	26	25	24	21	26	25	24	21	26	25	24	21	24	25	24	21	23	23	22	19
kW	1.19	1.21	1.25	1.28	1.27	1.30	1.34	1.38	1.35	1.38	1.42	1.47	1.42	1.45	1.50	1.54	1.48	1.51	1.56	1.61	1.53	1.56	1.61	1.66	
Amps	4.3	4.4	4.5	4.7	4.6	4.7	4.9	5.1	5.0	5.1	5.3	5.5	5.3	5.5	5.7	5.9	5.7	5.8	6.0	6.2	6.0	6.2	6.4	6.6	
Hi PR	217	233	247	257	243	262	277	288	277	298	315	328	315	339	358	374	355	382	403	420	392	422	445	465	
Lo PR	109	116	126	134	115	122	133	142	119	127	139	148	125	133	146	155	131	140	153	162	136	145	158	168	
MBh	16.6	17.0	17.8	19.0	16.3	16.6	17.4	18.5	15.9	16.2	16.9	18.1	15.5	15.8	16.5	17.6	14.7	15.0	15.7	16.8	13.6	13.9	14.5	15.5	
S/T	0.89	0.85	0.77	0.63	0.92	0.89	0.80	0.65	0.94	0.91	0.82	0.66	0.97	0.94	0.85	0.69	1.00	0.97	0.88	0.71	1.00	0.98	0.89	0.72	
ΔT	26	25	24	21	26	26	24	21	26	26	24	21	26	26	24	21	26	26	24	21	24	24	23	20	
kW	1.16	1.18	1.22	1.25	1.24	1.27	1.31	1.35	1.32	1.35	1.39	1.43	1.38	1.41	1.46	1.51	1.44	1.47	1.52	1.57	1.49	1.52	1.57	1.62	
Amps	4.2	4.3	4.4	4.6	4.5	4.6	4.8	4.9	4.9	5.0	5.2	5.3	5.2	5.3	5.5	5.7	5.5	5.7	5.8	6.1	5.9	6.0	6.2	6.4	
Hi PR	210	226	239	249	236	254	268	280	269	289	305	318	306	329	348	362	344	370	391	408	380	409	432	451	
Lo PR	105	112	122	130	111	118	129	138	116	123	134	143	122	129	141	150	127	136	148	158	132	140	153	163	

IDB: Entering Indoor Dry Bulb Temperature kW=Total system power Amps = outdoor unit amps (comp.+fan)

EXPANDED COOLING DATA — ASZ140241A* / CA*F3636*6A*+TXV / MBR800** *-1

IDB	OUTDOOR AMBIENT TEMPERATURE												ENTERING INDOOR WET BULB TEMPERATURE												
	65°F				75°F				85°F				95°F				105°F				115°F				
	59	63	67	71	59	63	67	71	59	63	67	71	59	63	67	71	59	63	67	71	59	63	67	71	
70	AIRFLOW	59	63	67	71	59	63	67	71	59	63	67	71	59	63	67	71	59	63	67	71	59	63	67	71
	MBh	23.5	24.4	26.7	-	23.0	23.8	26.1	-	22.4	23.2	25.5	-	21.9	22.7	24.8	-	20.8	21.5	23.6	-	19.3	20.0	21.9	-
	S/T	0.75	0.63	0.44	-	0.78	0.65	0.45	-	0.80	0.67	0.46	-	0.83	0.69	0.48	-	0.86	0.72	0.50	-	0.87	0.72	0.50	-
	ΔT	17	15	11	-	17	15	11	-	17	15	11	-	17	15	11	-	17	15	11	-	16	14	11	-
	kW	1.65	1.68	1.73	-	1.77	1.80	1.86	-	1.87	1.91	1.97	-	1.97	2.01	2.07	-	2.04	2.09	2.15	-	2.11	2.16	2.22	-
	Amps	10.1	10.2	10.4	-	10.5	10.7	10.9	-	11.0	11.2	11.4	-	11.5	11.7	11.9	-	12.0	12.2	12.4	-	12.4	12.6	12.9	-
	Hi PR	222	239	252	-	249	268	283	-	283	305	322	-	323	347	367	-	363	391	412	-	401	432	456	-
	Lo PR	110	117	128	-	116	124	135	-	121	129	140	-	127	135	147	-	133	142	155	-	138	146	160	-
	MBh	22.8	23.7	25.9	-	22.3	23.1	25.3	-	21.8	22.6	24.7	-	21.2	22.0	24.1	-	20.2	20.9	22.9	-	18.7	19.4	21.2	-
	S/T	0.72	0.60	0.42	-	0.74	0.62	0.43	-	0.76	0.64	0.44	-	0.79	0.66	0.46	-	0.82	0.68	0.47	-	0.83	0.69	0.48	-
	ΔT	18	15	12	-	18	16	12	-	18	16	12	-	18	16	12	-	18	15	12	-	17	14	11	-
	kW	1.64	1.67	1.72	-	1.75	1.79	1.84	-	1.86	1.90	1.95	-	1.95	1.99	2.05	-	2.03	2.07	2.14	-	2.09	2.14	2.21	-
Amps	10.0	10.1	10.3	-	10.5	10.6	10.8	-	11.0	11.1	11.4	-	11.4	11.6	11.9	-	11.9	12.1	12.3	-	12.3	12.5	12.8	-	
Hi PR	220	236	250	-	247	265	280	-	280	302	319	-	319	344	363	-	359	387	408	-	397	427	451	-	
Lo PR	109	116	127	-	115	122	134	-	120	127	139	-	126	134	146	-	132	140	153	-	136	145	158	-	
MBh	21.1	21.8	23.9	-	20.6	21.3	23.4	-	20.1	20.8	22.8	-	19.6	20.3	22.3	-	18.6	19.3	21.1	-	17.3	17.9	19.6	-	
S/T	0.69	0.58	0.40	-	0.72	0.60	0.42	-	0.74	0.62	0.43	-	0.76	0.63	0.44	-	0.79	0.66	0.46	-	0.80	0.66	0.46	-	
ΔT	18	16	12	-	18	16	12	-	18	16	12	-	18	16	12	-	18	16	12	-	17	15	11	-	
kW	1.60	1.63	1.68	-	1.72	1.75	1.80	-	1.82	1.85	1.91	-	1.90	1.94	2.00	-	1.98	2.02	2.08	-	2.04	2.09	2.15	-	
Amps	9.8	10.0	10.2	-	10.3	10.4	10.6	-	10.8	11.0	11.2	-	11.2	11.4	11.7	-	11.7	11.9	12.1	-	12.1	12.3	12.6	-	
Hi PR	213	229	242	-	239	257	272	-	272	293	309	-	310	333	352	-	349	375	396	-	385	414	438	-	
Lo PR	106	112	123	-	112	119	130	-	116	123	135	-	122	130	142	-	128	136	148	-	132	141	153	-	

75	MBh	23.9	24.6	26.7	28.6	23.4	24.1	26.0	27.9	22.8	23.5	25.4	27.3	22.2	22.9	24.8	26.6	21.1	21.8	23.6	25.3	19.6	20.2	21.8	23.4
	S/T	0.86	0.77	0.58	0.37	0.89	0.79	0.60	0.39	0.91	0.81	0.62	0.40	0.94	0.84	0.64	0.41	0.98	0.87	0.66	0.42	0.98	0.88	0.67	0.43
	ΔT	20	18	15	10	20	18	15	10	20	18	15	10	20	19	15	10	20	18	15	10	19	17	14	10
	kW	1.66	1.70	1.75	1.80	1.78	1.82	1.87	1.93	1.89	1.93	1.99	2.05	1.98	2.02	2.09	2.15	2.06	2.10	2.17	2.24	2.13	2.17	2.24	2.32
	Amps	10.1	10.2	10.4	10.7	10.6	10.7	10.9	11.2	11.1	11.3	11.5	11.8	11.6	11.8	12.0	12.3	12.0	12.2	12.5	12.8	12.5	12.7	13.0	13.3
	Hi PR	224	241	255	266	252	271	286	298	286	308	325	339	326	351	370	386	367	395	417	435	405	436	460	480
	Lo PR	111	118	129	138	117	125	136	145	122	130	142	151	128	136	149	159	134	143	156	166	139	148	161	172
	MBh	23.2	23.9	25.9	27.8	22.7	23.4	25.3	27.1	22.1	22.8	24.7	26.5	21.6	22.2	24.1	25.8	20.5	21.1	22.9	24.5	19.0	19.6	21.2	22.7
	S/T	0.82	0.73	0.55	0.36	0.85	0.76	0.57	0.37	0.87	0.78	0.59	0.38	0.90	0.80	0.61	0.39	0.93	0.83	0.63	0.41	0.94	0.84	0.63	0.41
	ΔT	21	19	15	11	21	19	16	11	21	19	16	11	21	19	16	11	21	19	16	11	19	18	15	10
	kW	1.65	1.68	1.73	1.78	1.77	1.80	1.86	1.92	1.87	1.91	1.97	2.03	1.97	2.01	2.07	2.13	2.04	2.09	2.15	2.22	2.11	2.16	2.22	2.30
	Amps	10.1	10.2	10.4	10.6	10.5	10.7	10.9	11.1	11.0	11.2	11.4	11.7	11.5	11.7	11.9	12.2	12.0	12.2	12.4	12.7	12.4	12.6	12.9	13.2
Hi PR	222	239	252	263	249	268	283	295	283	305	322	336	323	347	367	382	363	391	412	430	401	432	456	475	
Lo PR	110	117	128	136	116	124	135	144	121	129	140	150	127	135	147	157	133	142	155	165	138	146	160	170	
MBh	21.4	22.1	23.9	25.6	20.9	21.6	23.3	25.0	20.4	21.0	22.8	24.4	19.9	20.5	22.2	23.8	18.9	19.5	21.1	22.7	17.5	18.1	19.6	21.0	
S/T	0.79	0.70	0.53	0.34	0.82	0.73	0.55	0.36	0.84	0.75	0.57	0.36	0.86	0.77	0.58	0.38	0.90	0.80	0.61	0.39	0.90	0.81	0.61	0.39	
ΔT	21	19	16	11	21	19	16	11	21	19	16	11	21	20	16	11	21	19	16	11	20	18	15	10	
kW	1.61	1.64	1.69	1.74	1.73	1.76	1.82	1.87	1.83	1.87	1.92	1.98	1.92	1.96	2.02	2.08	2.00	2.04	2.10	2.17	2.06	2.10	2.17	2.24	
Amps	9.9	10.0	10.2	10.4	10.3	10.5	10.7	10.9	10.9	11.0	11.2	11.5	11.3	11.5	11.7	12.0	11.8	11.9	12.2	12.5	12.2	12.4	12.7	13.0	
Hi PR	215	232	245	255	242	260	275	286	275	296	312	326	313	337	356	371	352	379	400	417	389	419	442	461	
Lo PR	107	114	124	132	113	120	131	140	117	125	136	145	123	131	143	152	129	137	150	160	133	142	155	165	

IDB: Entering Indoor Dry Bulb Temperature Shaded area reflects ACCA (TVA) conditions kW=Total system power Amps = outdoor unit amps (comp. + fan)

EXPANDED COOLING DATA — ASZ140241A* / CA*F3636*6A*+TXV / MBR800** -1 (CONT.)

IDB	AIRFLOW	OUTDOOR AMBIENT TEMPERATURE												ENTERING INDOOR WET BULB TEMPERATURE											
		65°F				75°F				85°F				95°F				105°F				115°F			
		59	63	67	71	59	63	67	71	59	63	67	71	59	63	67	71	59	63	67	71	59	63	67	71
80	MBh	24.3	24.9	26.6	28.4	23.8	24.3	26.0	27.7	23.2	23.7	25.3	27.1	22.6	23.1	24.7	26.4	21.5	22.0	23.5	25.1	19.9	20.4	21.8	23.3
	S/T	0.94	0.88	0.72	0.54	1.00	0.91	0.74	0.56	1.00	0.94	0.76	0.57	1.00	0.97	0.79	0.59	1.00	1.00	0.82	0.61	1.00	1.00	0.82	0.62
	ΔT	22	21	18	15	22	21	19	15	22	21	19	15	22	21	19	15	21	21	18	15	19	20	17	14
	kW	1.67	1.71	1.76	1.81	1.80	1.83	1.89	1.95	1.90	1.94	2.00	2.06	2.00	2.04	2.10	2.17	2.08	2.12	2.19	2.26	2.15	2.19	2.26	2.33
	Amps	10.2	10.3	10.5	10.7	10.6	10.8	11.0	11.2	11.2	11.3	11.6	11.8	11.6	11.8	12.1	12.4	12.1	12.3	12.6	12.9	12.6	12.8	13.1	13.4
	Hi PR	226	244	257	268	254	273	289	301	289	311	328	343	329	354	374	390	370	399	421	439	409	440	465	485
	Lo PR	112	119	130	139	119	126	138	147	123	131	143	153	130	138	150	160	136	144	158	168	140	149	163	174
	MBh	23.6	24.1	25.8	27.6	23.1	23.6	25.2	26.9	22.5	23.0	24.6	26.3	22.0	22.5	24.0	25.7	20.9	21.3	22.8	24.4	19.3	19.8	21.1	22.6
	S/T	0.90	0.84	0.68	0.51	0.93	0.87	0.71	0.53	0.95	0.89	0.73	0.54	0.98	0.92	0.75	0.56	1.00	0.96	0.78	0.58	1.00	0.96	0.79	0.59
	ΔT	23	22	19	15	23	22	19	15	23	22	19	15	23	22	19	15	23	22	19	15	21	21	18	14
kW	1.66	1.70	1.75	1.80	1.78	1.82	1.87	1.93	1.89	1.93	1.99	2.05	1.98	2.02	2.09	2.15	2.06	2.10	2.17	2.24	2.13	2.17	2.24	2.32	
Amps	10.1	10.2	10.4	10.7	10.6	10.7	10.9	11.2	11.1	11.3	11.5	11.8	11.6	11.8	12.0	12.3	12.0	12.2	12.5	12.8	12.5	12.7	13.0	13.3	
Hi PR	224	241	255	266	252	271	286	298	286	308	325	339	326	351	370	386	367	395	417	435	405	436	460	480	
Lo PR	111	118	129	138	117	125	136	145	122	130	142	151	128	136	149	159	134	143	156	166	139	148	161	172	
MBh	21.8	22.3	23.8	25.5	21.3	21.8	23.3	24.9	20.8	21.3	22.7	24.3	20.3	20.7	22.2	23.7	19.3	19.7	21.0	22.5	17.9	18.2	19.5	20.8	
S/T	0.86	0.81	0.66	0.49	0.90	0.84	0.68	0.51	0.92	0.86	0.70	0.52	0.95	0.89	0.72	0.54	0.98	0.92	0.75	0.56	0.99	0.93	0.76	0.57	
ΔT	23	22	19	16	24	23	20	16	24	23	20	16	24	23	20	16	23	22	20	16	22	21	18	15	
kW	1.63	1.66	1.71	1.76	1.74	1.78	1.83	1.89	1.84	1.88	1.94	2.00	1.93	1.97	2.04	2.10	2.01	2.05	2.12	2.19	2.08	2.12	2.19	2.26	
Amps	9.9	10.1	10.3	10.5	10.4	10.5	10.7	11.0	10.9	11.1	11.3	11.6	11.4	11.5	11.8	12.1	11.8	12.0	12.3	12.6	12.3	12.5	12.7	13.1	
Hi PR	217	234	247	258	244	263	277	289	278	299	315	329	316	340	359	375	356	383	404	422	393	423	447	466	
Lo PR	108	115	125	133	114	121	132	141	118	126	138	146	124	132	144	154	130	139	151	161	135	143	157	167	

85	MBh	24.8	25.2	26.4	28.2	24.2	24.7	25.8	27.6	23.6	24.1	25.2	26.9	23.0	23.5	24.6	26.2	21.9	22.3	23.4	24.9	20.3	20.7	21.6	23.1
	S/T	0.98	0.95	0.86	0.70	1.00	0.98	0.89	0.72	1.00	1.00	0.91	0.74	1.00	1.00	0.94	0.76	1.00	1.00	0.98	0.79	1.00	1.00	0.98	0.80
	ΔT	23	23	22	19	23	23	22	19	23	23	22	19	22	23	22	19	21	21	22	19	19	20	20	18
	kW	1.69	1.72	1.77	1.83	1.81	1.85	1.90	1.96	1.92	1.96	2.02	2.08	2.01	2.05	2.12	2.19	2.09	2.14	2.21	2.28	2.16	2.21	2.28	2.35
	Amps	10.2	10.3	10.5	10.8	10.7	10.8	11.1	11.3	11.2	11.4	11.6	11.9	11.7	11.9	12.1	12.4	12.2	12.4	12.6	13.0	12.7	12.9	13.1	13.5
	Hi PR	229	246	260	271	257	276	292	304	292	314	332	346	332	358	378	394	374	402	425	443	413	445	470	490
	Lo PR	113	121	132	140	120	127	139	148	125	132	145	154	131	139	152	162	137	146	159	170	142	151	165	175
	MBh	24.0	24.5	25.7	27.4	23.5	23.9	25.1	26.8	22.9	23.4	24.5	26.1	22.4	22.8	23.9	25.5	21.2	21.7	22.7	24.2	19.7	20.1	21.0	22.4
	S/T	0.94	0.91	0.82	0.66	0.97	0.94	0.85	0.69	1.00	0.96	0.87	0.71	1.00	0.99	0.90	0.73	1.00	1.00	0.93	0.76	1.00	1.00	0.94	0.76
	ΔT	24	24	23	20	25	24	23	20	25	24	23	20	24	25	23	20	23	23	23	20	21	22	21	18
kW	1.67	1.71	1.76	1.81	1.80	1.83	1.89	1.95	1.90	1.94	2.00	2.06	2.00	2.04	2.10	2.17	2.08	2.12	2.19	2.26	2.15	2.19	2.26	2.33	
Amps	10.2	10.3	10.5	10.7	10.6	10.8	11.0	11.2	11.2	11.3	11.6	11.8	11.6	11.8	12.1	12.4	12.1	12.3	12.6	12.9	12.6	12.8	13.1	13.4	
Hi PR	226	244	257	268	254	273	289	301	289	311	328	343	329	354	374	390	370	399	421	439	409	440	465	485	
Lo PR	112	119	130	139	119	126	138	147	123	131	143	153	130	138	150	160	136	144	158	168	140	149	163	174	
MBh	22.2	22.6	23.7	25.3	21.7	22.1	23.1	24.7	21.2	21.6	22.6	24.1	20.6	21.0	22.0	23.5	19.6	20.0	20.9	22.3	18.2	18.5	19.4	20.7	
S/T	0.91	0.87	0.79	0.64	0.94	0.91	0.82	0.66	0.96	0.93	0.84	0.68	0.99	0.96	0.87	0.70	1.00	0.99	0.90	0.73	1.00	1.00	0.91	0.73	
ΔT	ΔT	24	23	20	25	25	23	20	25	25	23	20	25	25	24	20	24	25	23	20	22	23	22	19	
kW	1.64	1.67	1.72	1.77	1.75	1.79	1.84	1.90	1.86	1.90	1.95	2.02	1.95	1.99	2.05	2.12	2.03	2.07	2.13	2.20	2.09	2.14	2.21	2.28	
Amps	10.0	10.1	10.3	10.5	10.5	10.6	10.8	11.0	11.0	11.1	11.4	11.6	11.4	11.6	11.9	12.1	11.9	12.1	12.3	12.6	12.3	12.5	12.8	13.1	
Hi PR	220	236	250	260	246	265	280	292	280	302	319	332	319	344	363	378	359	387	408	426	397	427	451	470	
Lo PR	109	116	127	135	115	122	134	142	120	127	139	148	126	134	146	155	132	140	153	163	136	145	158	168	

IDB: Entering Indoor Dry Bulb Temperature Shaded area reflects AHRI conditions kW=Total system power Amps = outdoor unit amps (comp.+fan)

EXPANDED COOLING DATA — ASZ140301A* / CA*F3642*6A* +TXV / MBR1600** -1

IDB	AIRFLOW	OUTDOOR AMBIENT TEMPERATURE																							
		65°F				75°F				85°F				95°F				105°F				115°F			
		59	63	67	71	59	63	67	71	59	63	67	71	59	63	67	71	59	63	67	71	59	63	67	71
1181	MBh	28.2	29.3	32.0	-	27.6	28.6	31.3	-	26.9	27.9	30.6	-	26.3	27.2	29.8	-	24.9	25.8	28.3	-	23.1	23.9	26.2	-
	S/T	0.79	0.66	0.46	-	0.82	0.68	0.47	-	0.84	0.70	0.48	-	0.86	0.72	0.50	-	0.90	0.75	0.52	-	0.90	0.75	0.52	-
	ΔT	17	15	11	-	17	15	11	-	18	15	11	-	18	15	12	-	17	15	11	-	16	14	11	-
	kW	1.99	2.03	2.09	-	2.13	2.18	2.24	-	2.26	2.30	2.37	-	2.37	2.42	2.49	-	2.46	2.51	2.59	-	2.54	2.59	2.67	-
	Amps	2.3	2.5	2.7	-	2.9	3.0	3.3	-	3.5	3.7	4.0	-	4.1	4.3	4.6	-	4.6	4.8	5.1	-	5.1	5.4	5.7	-
	Hi PR	221	237	251	-	247	266	281	-	281	303	320	-	321	345	364	-	361	388	410	-	398	429	453	-
	Lo PR	112	119	130	-	118	126	137	-	123	131	143	-	129	137	150	-	135	144	157	-	140	149	162	-
	MBh	27.4	28.4	31.1	-	26.8	27.7	30.4	-	26.1	27.1	29.7	-	25.5	26.4	28.9	-	24.2	25.1	27.5	-	22.4	23.2	25.5	-
	S/T	0.75	0.63	0.43	-	0.78	0.65	0.45	-	0.80	0.67	0.46	-	0.82	0.69	0.48	-	0.85	0.71	0.49	-	0.86	0.72	0.50	-
	ΔT	18	16	12	-	18	16	12	-	18	16	12	-	18	16	12	-	18	16	12	-	17	15	11	-
70	kW	1.98	2.02	2.08	-	2.12	2.16	2.22	-	2.24	2.29	2.36	-	2.35	2.40	2.47	-	2.44	2.49	2.57	-	2.52	2.57	2.65	-
	Amps	2.3	2.4	2.6	-	2.8	3.0	3.2	-	3.4	3.6	3.9	-	4.0	4.2	4.5	-	4.5	4.7	5.1	-	5.1	5.3	5.6	-
	Hi PR	218	235	248	-	245	264	278	-	279	300	317	-	317	342	361	-	357	384	406	-	394	425	448	-
	Lo PR	111	118	129	-	117	124	136	-	122	129	141	-	128	136	148	-	134	142	155	-	138	147	161	-
	MBh	25.3	26.2	28.7	-	24.7	25.6	28.1	-	24.1	25.0	27.4	-	23.5	24.4	26.7	-	22.3	23.2	25.4	-	20.7	21.5	23.5	-
	S/T	0.72	0.60	0.42	-	0.75	0.63	0.43	-	0.77	0.64	0.44	-	0.79	0.66	0.46	-	0.82	0.69	0.48	-	0.83	0.69	0.48	-
	ΔT	18	16	12	-	19	16	12	-	19	16	12	-	19	16	12	-	18	16	12	-	17	15	11	-
	kW	1.94	1.97	2.03	-	2.07	2.11	2.17	-	2.19	2.23	2.30	-	2.30	2.34	2.41	-	2.38	2.43	2.51	-	2.46	2.51	2.59	-
	Amps	2.1	2.2	2.4	-	2.6	2.8	3.0	-	3.2	3.4	3.7	-	3.7	3.9	4.2	-	4.3	4.5	4.8	-	4.8	5.0	5.3	-
	Hi PR	212	228	241	-	238	256	270	-	270	291	307	-	308	331	350	-	346	373	394	-	383	412	435	-
Lo PR	107	114	125	-	114	121	132	-	118	126	137	-	124	132	144	-	130	138	151	-	134	143	156	-	

1181	MBh	28.7	29.5	32.0	34.3	28.0	28.9	31.2	33.5	27.4	28.2	30.5	32.7	26.7	27.5	29.8	31.9	25.4	26.1	28.3	30.3	23.5	24.2	26.2	28.1
	S/T	0.89	0.80	0.61	0.39	0.93	0.83	0.63	0.40	0.95	0.85	0.64	0.41	0.98	0.88	0.66	0.43	1.00	0.91	0.69	0.44	1.00	0.92	0.69	0.45
	ΔT	20	18	15	10	20	19	15	11	20	19	15	11	20	19	15	11	20	19	15	10	18	17	14	10
	kW	2.01	2.05	2.11	2.17	2.15	2.19	2.26	2.33	2.28	2.32	2.39	2.47	2.39	2.44	2.51	2.59	2.48	2.53	2.61	2.69	2.56	2.61	2.70	2.78
	Amps	2.4	2.5	2.8	3.0	2.9	3.1	3.4	3.7	3.6	3.8	4.0	4.4	4.1	4.3	4.6	5.0	4.7	4.9	5.2	5.6	5.2	5.5	5.8	6.2
	Hi PR	223	240	253	264	250	269	284	296	284	306	323	337	324	348	368	384	364	392	414	432	402	433	457	477
	Lo PR	113	120	131	140	119	127	139	148	124	132	144	153	130	139	151	161	137	145	159	169	141	150	164	175
	MBh	27.9	28.7	31.1	33.3	27.2	28.0	30.3	32.6	26.6	27.4	29.6	31.8	25.9	26.7	28.9	31.0	24.6	25.4	27.4	29.5	22.8	23.5	25.4	27.3
	S/T	0.85	0.76	0.58	0.37	0.88	0.79	0.60	0.38	0.91	0.81	0.61	0.39	0.94	0.84	0.63	0.41	0.97	0.87	0.66	0.42	0.98	0.88	0.66	0.43
	ΔT	21	19	16	11	21	19	16	11	21	19	16	11	21	20	16	11	21	19	16	11	20	18	15	10
75	kW	1.99	2.03	2.09	2.15	2.14	2.18	2.24	2.31	2.26	2.30	2.37	2.45	2.37	2.42	2.49	2.57	2.46	2.51	2.59	2.67	2.54	2.59	2.67	2.76
	Amps	2.3	2.5	2.7	3.0	2.9	3.0	3.3	3.6	3.5	3.7	4.0	4.3	4.1	4.3	4.6	4.9	4.6	4.8	5.1	5.5	5.1	5.4	5.7	6.1
	Hi PR	221	237	251	261	248	266	281	293	281	303	320	334	321	345	364	380	361	388	410	427	399	429	453	472
	Lo PR	112	119	130	138	118	126	137	146	123	131	143	152	129	137	150	160	135	144	157	167	140	149	162	173
	MBh	25.7	26.5	28.7	30.8	25.1	25.9	28.0	30.0	24.5	25.2	27.3	29.3	23.9	24.6	26.7	28.6	22.7	23.4	25.3	27.2	21.1	21.7	23.5	25.2
	S/T	0.82	0.74	0.56	0.36	0.85	0.76	0.58	0.37	0.87	0.78	0.59	0.38	0.90	0.81	0.61	0.39	0.94	0.84	0.63	0.41	0.94	0.84	0.64	0.41
	ΔT	21	19	16	11	21	20	16	11	21	20	16	11	22	20	16	11	21	20	16	11	20	18	15	10
	kW	1.95	1.99	2.05	2.11	2.09	2.13	2.19	2.26	2.21	2.25	2.32	2.39	2.31	2.36	2.43	2.51	2.40	2.45	2.53	2.61	2.48	2.53	2.61	2.69
	Amps	2.1	2.3	2.5	2.8	2.7	2.8	3.1	3.4	3.3	3.5	3.7	4.0	3.8	4.0	4.3	4.6	4.4	4.6	4.9	5.2	4.9	5.1	5.4	5.8
	Hi PR	214	230	243	254	240	258	273	285	273	294	310	324	311	335	353	369	350	376	398	415	387	416	439	458
Lo PR	109	115	126	134	115	122	133	142	119	127	138	147	125	133	145	155	131	140	152	162	136	144	158	168	

IDB: Entering Indoor Dry Bulb Temperature Shaded area reflects ACCA (TVA) conditions kW=Total system power Amps = outdoor unit amps (comp. +fan)

EXPANDED COOLING DATA — ASZ140301A* / CA*F3642*6A* +TXV / MBR1600** -1 (CONT.)

IDB	AIRFLOW	OUTDOOR AMBIENT TEMPERATURE												ENTERING INDOOR WET BULB TEMPERATURE											
		65°F				75°F				85°F				95°F				105°F				115°F			
		59	63	67	71	59	63	67	71	59	63	67	71	59	63	67	71	59	63	67	71	59	63	67	71
1181	MBh	29.2	29.8	31.9	34.1	28.5	29.2	31.1	33.3	27.9	28.5	30.4	32.5	27.2	27.8	29.7	31.7	25.8	26.4	28.2	30.1	23.9	24.4	26.1	27.9
	S/T	1.00	0.92	0.75	0.56	1.00	0.95	0.78	0.58	1.00	1.00	0.80	0.59	1.00	1.00	0.82	0.61	1.00	1.00	0.85	0.64	1.00	1.00	0.86	0.64
	ΔT	23	21	19	15	22	22	19	15	22	22	19	15	21	22	19	15	20	21	19	15	19	19	17	14
	kW	2.02	2.06	2.12	2.19	2.17	2.21	2.28	2.35	2.29	2.34	2.41	2.49	2.40	2.45	2.53	2.61	2.50	2.55	2.63	2.71	2.58	2.64	2.72	2.80
	Amps	2.4	2.6	2.8	3.1	3.0	3.2	3.4	3.7	3.7	3.9	4.1	4.5	4.2	4.4	4.7	5.1	4.8	5.0	5.3	5.7	5.3	5.6	5.9	6.3
	Hi PR	225	242	256	267	253	272	287	299	287	309	326	340	327	352	372	388	368	396	418	436	407	438	462	482
	Lo PR	114	121	133	141	121	128	140	149	125	133	146	155	132	140	153	163	138	147	160	171	143	152	166	177
	MBh	28.4	29.0	31.0	33.1	27.7	28.3	30.2	32.3	27.0	27.6	29.5	31.6	26.4	27.0	28.8	30.8	25.1	25.6	27.4	29.2	23.2	23.7	25.3	27.1
	S/T	0.94	0.88	0.71	0.53	0.97	0.91	0.74	0.55	0.99	0.93	0.76	0.57	1.00	0.96	0.78	0.59	1.00	1.00	0.81	0.61	1.00	1.00	0.82	0.61
	ΔT	23	22	19	15	24	23	20	16	24	23	20	16	23	23	20	16	22	22	19	16	20	21	18	15
80	kW	2.01	2.05	2.11	2.17	2.15	2.19	2.26	2.33	2.28	2.32	2.39	2.47	2.39	2.44	2.51	2.59	2.48	2.53	2.61	2.69	2.56	2.61	2.70	2.78
	Amps	2.4	2.5	2.8	3.0	2.9	3.1	3.4	3.7	3.6	3.8	4.0	4.4	4.1	4.3	4.6	5.0	4.7	4.9	5.2	5.6	5.2	5.5	5.8	6.2
	Hi PR	223	240	253	264	250	269	284	296	284	306	323	337	324	348	368	384	364	392	414	432	403	433	457	477
	Lo PR	113	120	131	140	119	127	139	148	124	132	144	154	130	139	151	161	137	145	159	169	141	150	164	175
	MBh	26.2	26.7	28.6	30.5	25.6	26.1	27.9	29.8	25.0	25.5	27.2	29.1	24.3	24.9	26.6	28.4	23.1	23.6	25.3	27.0	21.4	21.9	23.4	25.0
	S/T	0.90	0.85	0.69	0.51	0.93	0.88	0.71	0.53	0.96	0.90	0.73	0.55	0.99	0.93	0.75	0.56	1.03	0.96	0.78	0.59	1.04	0.97	0.79	0.59
	ΔT	24	23	20	16	24	23	20	16	24	23	20	16	24	23	20	16	24	23	20	16	22	21	18	15
	kW	1.97	2.00	2.06	2.12	2.10	2.14	2.21	2.27	2.22	2.27	2.34	2.41	2.33	2.38	2.45	2.53	2.42	2.47	2.55	2.63	2.50	2.55	2.63	2.72
	Amps	2.2	2.4	2.6	2.8	2.7	2.9	3.2	3.4	3.4	3.5	3.8	4.1	3.9	4.1	4.4	4.7	4.4	4.7	5.0	5.3	5.0	5.2	5.5	5.9
	Hi PR	216	233	246	256	243	261	276	287	276	297	313	327	314	338	357	372	353	380	402	419	390	420	444	463
Lo PR	110	117	127	136	116	123	135	143	120	128	140	149	126	135	147	156	133	141	154	164	137	146	159	170	

1181	MBh	29.7	30.3	31.7	33.9	29.0	29.6	31.0	33.1	28.3	28.9	30.3	32.3	27.6	28.2	29.5	31.5	26.3	26.8	28.0	29.9	24.3	24.8	26.0	27.7
	S/T	1.00	0.99	0.90	0.73	1.00	1.00	0.93	0.75	1.00	1.00	0.95	0.77	1.00	1.00	0.98	0.80	1.00	1.00	1.00	0.83	1.00	1.00	1.00	0.83
	ΔT	23	23	22	19	23	23	22	19	22	22	22	19	22	22	23	20	20	21	22	19	19	19	20	18
	kW	2.04	2.08	2.14	2.20	2.18	2.23	2.29	2.36	2.31	2.36	2.43	2.50	2.42	2.47	2.55	2.63	2.52	2.57	2.65	2.74	2.60	2.66	2.74	2.83
	Amps	2.5	2.7	2.9	3.2	3.1	3.3	3.5	3.8	3.7	3.9	4.2	4.5	4.3	4.5	4.8	5.2	4.9	5.1	5.4	5.8	5.4	5.7	6.0	6.4
	Hi PR	227	245	258	269	255	274	290	302	290	312	330	344	330	356	375	392	372	400	422	440	411	442	467	487
	Lo PR	115	123	134	143	122	130	141	151	127	135	147	157	133	141	154	164	139	148	162	172	144	153	167	178
	MBh	28.9	29.4	30.8	32.9	28.2	28.7	30.1	32.1	27.5	28.0	29.4	31.3	26.8	27.4	28.7	30.6	25.5	26.0	27.2	29.0	23.6	24.1	25.2	26.9
	S/T	0.98	0.95	0.85	0.69	1.00	0.98	0.88	0.72	1.00	1.00	0.91	0.74	1.00	1.00	0.94	0.76	1.00	1.00	0.97	0.79	1.00	1.00	0.98	0.80
	ΔT	25	24	23	20	25	25	23	20	24	25	23	20	24	24	23	20	22	23	23	20	21	21	22	19
85	kW	2.02	2.06	2.12	2.19	2.17	2.21	2.28	2.35	2.29	2.34	2.41	2.49	2.40	2.45	2.53	2.61	2.50	2.55	2.63	2.71	2.58	2.64	2.72	2.80
	Amps	2.4	2.6	2.8	3.1	3.0	3.2	3.4	3.7	3.7	3.9	4.1	4.5	4.2	4.4	4.7	5.1	4.8	5.0	5.3	5.7	5.3	5.6	5.9	6.3
	Hi PR	225	242	256	267	253	272	287	299	287	309	326	340	327	352	372	388	368	396	418	436	407	438	462	482
	Lo PR	114	121	133	141	121	128	140	149	125	133	146	155	132	140	153	163	138	147	160	171	143	152	166	177
	MBh	26.6	27.1	28.4	30.3	26.0	26.5	27.8	29.6	25.4	25.9	27.1	28.9	24.8	25.3	26.4	28.2	23.5	24.0	25.1	26.8	21.8	22.2	23.3	24.8
	S/T	0.95	0.91	0.82	0.67	0.98	0.95	0.85	0.69	1.00	0.97	0.87	0.71	1.00	1.00	0.90	0.73	1.00	1.00	0.94	0.76	1.00	1.00	0.94	0.77
	ΔT	25	25	23	20	25	25	24	21	25	25	24	21	25	25	24	21	24	24	24	21	22	22	22	19
	kW	1.98	2.02	2.08	2.14	2.12	2.16	2.22	2.29	2.24	2.29	2.35	2.43	2.35	2.40	2.47	2.55	2.44	2.49	2.57	2.65	2.52	2.57	2.65	2.74
	Amps	2.3	2.4	2.6	2.9	2.8	3.0	3.2	3.5	3.4	3.6	3.9	4.2	4.0	4.2	4.5	4.8	4.5	4.7	5.0	5.4	5.1	5.3	5.6	6.0
	Hi PR	218	235	248	259	245	264	278	290	279	300	317	330	317	341	361	376	357	384	406	423	394	424	448	467
Lo PR	111	118	129	137	117	124	136	145	122	129	141	150	128	136	148	158	134	142	155	166	138	147	161	171	

IDB: Entering Indoor Dry Bulb Temperature Shaded area reflects AHRI conditions kW=Total system power Amps = outdoor unit amps (comp.+fan)

EXPANDED COOLING DATA — AS2140361A* / CA*F4860*6A*+TXV / MBR1600** -1

IDB	AIRFLOW	OUTDOOR AMBIENT TEMPERATURE																							
		65°F				75°F				85°F				95°F				105°F				115°F			
		59	63	67	71	59	63	67	71	59	63	67	71	59	63	67	71	59	63	67	71	59	63	67	71
1181	MBh	33.9	35.1	38.5	-	33.1	34.3	37.6	-	32.3	33.5	36.7	-	31.5	32.7	35.8	-	30.0	31.1	34.0	-	27.8	28.8	31.5	-
	S/T	0.72	0.60	0.42	-	0.75	0.63	0.43	-	0.77	0.64	0.44	-	0.79	0.66	0.46	-	0.82	0.69	0.48	-	0.83	0.69	0.48	-
	ΔT	19	17	13	-	19	17	13	-	19	17	13	-	19	17	13	-	19	17	13	-	18	16	12	-
	kW	2.34	2.39	2.46	-	2.51	2.56	2.64	-	2.66	2.72	2.80	-	2.79	2.85	2.94	-	2.90	2.96	3.06	-	3.00	3.06	3.16	-
	Amps	8.6	8.8	9.1	-	9.3	9.5	9.8	-	10.1	10.3	10.6	-	10.7	11.0	11.3	-	11.4	11.7	12.0	-	12.0	12.3	12.7	-
	Hi PR	218	235	248	-	245	264	278	-	279	300	317	-	317	342	361	-	357	384	406	-	395	425	448	-
	Lo PR	105	112	122	-	111	118	129	-	115	123	134	-	121	129	141	-	127	135	148	-	132	140	153	-
	MBh	32.9	34.1	37.4	-	32.2	33.3	36.5	-	31.4	32.5	35.6	-	30.6	31.7	34.8	-	29.1	30.2	33.0	-	26.9	27.9	30.6	-
	S/T	0.69	0.58	0.40	-	0.71	0.60	0.41	-	0.73	0.61	0.42	-	0.76	0.63	0.44	-	0.79	0.66	0.45	-	0.79	0.66	0.46	-
	ΔT	20	17	13	-	20	17	13	-	20	17	13	-	20	18	13	-	20	17	13	-	19	16	12	-
70	kW	2.33	2.37	2.44	-	2.49	2.54	2.62	-	2.64	2.69	2.78	-	2.77	2.83	2.92	-	2.88	2.94	3.03	-	2.98	3.04	3.14	-
	Amps	8.6	8.8	9.0	-	9.2	9.4	9.7	-	10.0	10.2	10.5	-	10.6	10.9	11.2	-	11.3	11.6	11.9	-	11.9	12.2	12.6	-
	Hi PR	216	233	246	-	243	261	276	-	276	297	314	-	314	338	357	-	354	380	402	-	391	420	444	-
	Lo PR	104	111	121	-	110	117	128	-	114	122	133	-	120	128	140	-	126	134	146	-	130	139	151	-
	MBh	30.4	31.5	34.5	-	29.7	30.8	33.7	-	29.0	30.0	32.9	-	28.3	29.3	32.1	-	26.9	27.8	30.5	-	24.9	25.8	28.2	-
	S/T	0.67	0.56	0.38	-	0.69	0.58	0.40	-	0.71	0.59	0.41	-	0.73	0.61	0.42	-	0.76	0.63	0.44	-	0.76	0.64	0.44	-
	ΔT	20	18	13	-	20	18	13	-	20	18	13	-	21	18	14	-	20	18	13	-	19	16	12	-
	kW	2.28	2.32	2.39	-	2.44	2.49	2.56	-	2.58	2.63	2.71	-	2.71	2.76	2.85	-	2.81	2.87	2.96	-	2.90	2.97	3.06	-
	Amps	8.4	8.5	8.8	-	9.0	9.2	9.5	-	9.7	9.9	10.3	-	10.4	10.6	10.9	-	11.0	11.2	11.6	-	11.6	11.9	12.3	-
	Hi PR	210	226	238	-	235	253	267	-	268	288	304	-	305	328	346	-	343	369	390	-	379	408	431	-
Lo PR	101	107	117	-	107	114	124	-	111	118	129	-	117	124	135	-	122	130	142	-	126	134	147	-	

1181	MBh	34.5	35.5	38.4	41.2	33.7	34.7	37.5	40.3	32.9	33.8	36.6	39.3	32.1	33.0	35.7	38.4	30.5	31.4	34.0	36.4	28.2	29.1	31.5	33.8
	S/T	0.82	0.74	0.56	0.36	0.85	0.76	0.58	0.37	0.87	0.78	0.59	0.38	0.90	0.81	0.61	0.39	0.94	0.84	0.63	0.41	0.94	0.84	0.64	0.41
	ΔT	22	20	17	11	22	21	17	12	22	21	17	12	23	21	17	12	22	20	17	12	21	19	16	11
	kW	2.36	2.41	2.48	2.55	2.53	2.58	2.66	2.74	2.68	2.74	2.82	2.91	2.81	2.87	2.96	3.06	2.93	2.99	3.08	3.18	3.02	3.09	3.19	3.29
	Amps	8.7	8.9	9.2	9.5	9.4	9.6	9.9	10.3	10.2	10.4	10.7	11.1	10.8	11.1	11.4	11.8	11.5	11.8	12.1	12.6	12.1	12.4	12.8	13.3
	Hi PR	221	237	251	261	248	266	281	293	282	303	320	334	321	345	364	380	361	388	410	428	399	429	453	472
	Lo PR	106	113	123	131	112	119	130	139	117	124	136	144	123	130	142	152	128	137	149	159	133	141	154	164
	MBh	33.5	34.5	37.3	40.0	32.7	33.7	36.4	39.1	31.9	32.9	35.6	38.2	31.1	32.1	34.7	37.2	29.6	30.5	33.0	35.4	27.4	28.2	30.5	32.8
	S/T	0.78	0.70	0.53	0.34	0.81	0.73	0.55	0.35	0.83	0.75	0.56	0.36	0.86	0.77	0.58	0.37	0.89	0.80	0.60	0.39	0.90	0.81	0.61	0.39
	ΔT	23	21	17	12	23	21	18	12	23	21	18	12	23	22	18	12	23	21	17	12	22	20	16	11
75	kW	2.34	2.39	2.46	2.54	2.51	2.56	2.64	2.72	2.66	2.72	2.80	2.89	2.79	2.85	2.94	3.03	2.90	2.97	3.06	3.16	3.00	3.06	3.16	3.26
	Amps	8.7	8.8	9.1	9.4	9.3	9.5	9.8	10.2	10.1	10.3	10.6	11.0	10.7	11.0	11.3	11.7	11.4	11.7	12.0	12.5	12.0	12.3	12.7	13.2
	Hi PR	218	235	248	259	245	264	279	290	279	300	317	330	317	342	361	376	357	384	406	423	395	425	448	468
	Lo PR	105	112	122	130	111	118	129	137	116	123	134	143	121	129	141	150	127	135	148	157	132	140	153	163
	MBh	30.9	31.8	34.4	37.0	30.2	31.1	33.6	36.1	29.5	30.3	32.8	35.2	28.7	29.6	32.0	34.4	27.3	28.1	30.4	32.7	25.3	26.0	28.2	30.3
	S/T	0.76	0.68	0.51	0.33	0.78	0.70	0.53	0.34	0.80	0.72	0.54	0.35	0.83	0.74	0.56	0.36	0.86	0.77	0.58	0.37	0.87	0.78	0.59	0.38
	ΔT	23	22	18	12	24	22	18	12	24	22	18	12	24	22	18	12	24	22	18	12	22	20	17	11
	kW	2.29	2.34	2.41	2.48	2.46	2.51	2.58	2.66	2.60	2.65	2.73	2.82	2.73	2.78	2.87	2.96	2.84	2.89	2.98	3.08	2.93	2.99	3.08	3.18
	Amps	8.4	8.6	8.9	9.2	9.1	9.3	9.6	9.9	9.8	10.0	10.4	10.7	10.5	10.7	11.0	11.4	11.1	11.3	11.7	12.1	11.7	12.0	12.4	12.8
	Hi PR	212	228	241	251	238	256	270	282	270	291	307	320	308	331	350	365	346	373	394	411	383	412	435	454
Lo PR	102	109	119	126	108	115	125	133	112	119	130	139	118	125	137	146	123	131	143	153	128	136	148	158	

IDB: Entering Indoor Dry Bulb Temperature Shaded area reflects ACCA (TVA) conditions kW=Total system power Amps = outdoor unit amps (comp. + fan)

EXPANDED COOLING DATA — AS2140361A* / CA*F4860*6A*+TXV / MBR1600** -1 (CONT.)

IDB	AIRFLOW	OUTDOOR AMBIENT TEMPERATURE																							
		65°F				75°F				85°F				95°F				105°F				115°F			
		59	63	67	71	59	63	67	71	59	63	67	71	59	63	67	71	59	63	67	71	59	63	67	71
1181	MBh	35.09	35.86	38.31	40.95	34.28	35.03	37.42	40.00	33.46	34.19	36.53	39.05	32.64	33.36	35.64	38.10	31.01	31.69	33.86	36.19	28.73	29.35	31.36	33.53
	S/T	0.90	0.85	0.69	0.51	0.93	0.88	0.71	0.53	0.96	0.90	0.73	0.55	1.00	0.93	0.75	0.56	1.00	0.96	0.78	0.59	1.00	0.97	0.79	0.59
	ΔT	25	24	21	16	25	24	21	17	25	24	21	17	25	24	21	17	25	24	21	16	22	22	19	15
	kW	2.38	2.43	2.50	2.57	2.55	2.60	2.68	2.77	2.70	2.76	2.84	2.93	2.84	2.90	2.99	3.08	2.95	3.01	3.11	3.21	3.05	3.11	3.21	3.32
	Amps	8.8	9.0	9.3	9.6	9.5	9.7	10.0	10.3	10.3	10.5	10.8	11.2	10.9	11.2	11.5	12.0	11.6	11.9	12.3	12.7	12.3	12.5	13.0	13.4
	Hi PR	223	240	253	264	250	269	284	296	284	306	323	337	324	349	368	384	364	392	414	432	403	433	457	477
	Lo PR	107	114	125	133	113	121	132	140	118	125	137	146	124	132	144	153	130	138	151	160	134	143	156	166
	MBh	34.1	34.8	37.2	39.8	33.3	34.0	36.3	38.8	32.5	33.2	35.5	37.9	31.7	32.4	34.6	37.0	30.1	30.8	32.9	35.1	27.9	28.5	30.4	32.5
	S/T	0.86	0.81	0.66	0.49	0.89	0.84	0.68	0.51	0.91	0.86	0.70	0.52	0.94	0.88	0.72	0.54	0.98	0.92	0.75	0.56	0.99	0.93	0.75	0.56
	ΔT	26	25	21	17	26	25	22	17	26	25	22	17	26	25	22	17	26	25	22	17	24	23	20	16
80	kW	2.36	2.41	2.48	2.56	2.53	2.58	2.66	2.74	2.68	2.74	2.82	2.91	2.81	2.87	2.96	3.06	2.93	2.99	3.08	3.18	3.02	3.09	3.19	3.29
	Amps	8.7	8.9	9.2	9.5	9.4	9.6	9.9	10.3	10.2	10.4	10.7	11.1	10.8	11.1	11.4	11.8	11.5	11.8	12.1	12.6	12.2	12.4	12.8	13.3
	Hi PR	221	237	251	261	248	266	281	293	282	303	320	334	321	345	364	380	361	388	410	428	399	429	453	472
	Lo PR	106	113	123	131	112	119	130	139	117	124	136	144	123	130	142	152	128	137	149	159	133	141	154	164
	MBh	31.4	32.1	34.3	36.7	30.7	31.4	33.5	35.8	30.0	30.6	32.7	35.0	29.3	29.9	31.9	34.1	27.8	28.4	30.3	32.4	25.7	26.3	28.1	30.0
	S/T	0.83	0.78	0.63	0.47	0.86	0.81	0.66	0.49	0.88	0.83	0.67	0.50	0.91	0.85	0.69	0.52	0.94	0.89	0.72	0.54	0.95	0.89	0.73	0.54
	ΔT	26	25	22	17	26	25	22	18	26	25	22	18	27	26	22	18	26	25	22	17	25	23	20	16
	kW	2.31	2.36	2.42	2.50	2.47	2.52	2.60	2.68	2.62	2.67	2.76	2.84	2.75	2.81	2.89	2.98	2.86	2.92	3.01	3.10	2.95	3.01	3.11	3.21
	Amps	8.5	8.7	9.0	9.3	9.1	9.4	9.6	10.0	9.9	10.1	10.4	10.8	10.5	10.8	11.1	11.5	11.2	11.5	11.8	12.2	11.8	12.1	12.5	13.0
	Hi PR	214	230	243	254	240	258	273	285	273	294	310	324	311	335	353	369	350	377	398	415	387	416	439	458
Lo PR	103	110	120	127	109	116	126	135	113	120	131	140	119	126	138	147	125	133	145	154	129	137	150	159	

1181	MBh	35.71	36.40	38.12	40.67	34.88	35.55	37.23	39.72	34.04	34.70	36.35	38.78	33.21	33.86	35.46	37.83	31.55	32.16	33.69	35.94	29.23	29.79	31.20	33.29
	S/T	0.95	0.91	0.82	0.67	0.98	0.95	0.85	0.69	1.00	0.97	0.87	0.71	1.00	1.00	0.90	0.73	1.00	1.00	0.94	0.76	1.00	1.00	0.94	0.77
	ΔT	26	26	24	21	27	26	25	21	26	26	25	21	26	26	25	22	25	25	25	21	23	23	23	20
	kW	2.40	2.45	2.52	2.59	2.57	2.62	2.70	2.79	2.72	2.78	2.87	2.96	2.86	2.92	3.01	3.11	2.97	3.04	3.13	3.23	3.07	3.14	3.24	3.34
	Amps	8.9	9.1	9.4	9.7	9.6	9.8	10.1	10.4	10.3	10.6	10.9	11.3	11.0	11.3	11.6	12.1	11.7	12.0	12.4	12.8	12.4	12.7	13.1	13.6
	Hi PR	225	242	256	267	253	272	287	299	287	309	326	340	327	352	372	388	368	396	418	436	407	438	462	482
	Lo PR	108	115	126	134	115	122	133	142	119	127	138	147	125	133	145	155	131	139	152	162	136	144	157	168
	MBh	34.7	35.3	37.0	39.5	33.9	34.5	36.1	38.6	33.1	33.7	35.3	37.6	32.2	32.9	34.4	36.7	30.6	31.2	32.7	34.9	28.4	28.9	30.3	32.3
	S/T	0.90	0.87	0.79	0.64	0.93	0.90	0.81	0.66	0.96	0.92	0.83	0.68	0.99	0.95	0.86	0.70	1.00	0.99	0.89	0.73	1.00	1.00	0.90	0.73
	ΔT	27	27	25	22	28	27	26	22	28	27	26	22	28	27	26	22	27	27	26	22	25	25	24	21
85	kW	2.38	2.43	2.50	2.57	2.55	2.60	2.68	2.77	2.70	2.76	2.84	2.93	2.84	2.90	2.99	3.08	2.95	3.01	3.11	3.21	3.05	3.11	3.21	3.32
	Amps	8.8	9.0	9.3	9.6	9.5	9.7	10.0	10.3	10.3	10.5	10.8	11.2	10.9	11.2	11.5	12.0	11.6	11.9	12.3	12.7	12.3	12.5	13.0	13.4
	Hi PR	223	240	253	264	250	269	284	296	284	306	323	337	324	349	368	384	364	392	414	432	403	433	457	477
	Lo PR	107	114	125	133	113	121	132	140	118	125	137	146	124	132	144	153	130	138	151	160	134	143	156	166
	MBh	32.0	32.6	34.2	36.4	31.3	31.9	33.4	35.6	30.5	31.1	32.6	34.7	29.8	30.3	31.8	33.9	28.3	28.8	30.2	32.2	26.2	26.7	28.0	29.8
	S/T	0.87	0.84	0.76	0.61	0.90	0.87	0.78	0.64	0.92	0.89	0.80	0.65	0.95	0.92	0.83	0.67	0.99	0.95	0.86	0.70	1.00	0.96	0.87	0.71
	ΔT	28	27	26	22	28	28	26	23	28	28	26	23	28	28	26	23	28	28	26	23	26	26	24	21
	kW	2.33	2.37	2.44	2.52	2.49	2.54	2.62	2.70	2.64	2.69	2.78	2.86	2.77	2.83	2.92	3.01	2.88	2.94	3.03	3.13	2.98	3.04	3.13	3.24
	Amps	8.6	8.8	9.0	9.4	9.2	9.4	9.7	10.1	10.0	10.2	10.5	10.9	10.6	10.9	11.2	11.6	11.3	11.6	11.9	12.4	11.9	12.2	12.6	13.1
	Hi PR	216	233	246	256	243	261	276	287	276	297	313	327	314	338	357	372	353	380	402	419	391	420	444	463
Lo PR	104	111	121	129	110	117	128	136	114	122	133	141	120	128	139	149	126	134	146	156	130	138	151	161	

IDB: Entering Indoor Dry Bulb Temperature Shaded area reflects AHRI conditions kW=Total system power Amps = outdoor unit amps (comp.+fan)

EXPANDED COOLING DATA — ASZ140361B* / AR*F374316B*

IDB	AIRFLOW	OUTDOOR AMBIENT TEMPERATURE												ENTERING INDOOR WET BULB TEMPERATURE											
		65°F				75°F				85°F				95°F				105°F				115°F			
		59	63	67	71	59	63	67	71	59	63	67	71	59	63	67	71	59	63	67	71	59	63	67	71
70	MBh	30.7	31.9	34.9	-	30.0	31.1	34.1	-	29.3	30.4	33.3	-	28.6	29.6	32.5	-	27.2	28.2	30.8	-	25.2	26.1	28.6	-
	S/T	0.72	0.60	0.42	-	0.75	0.63	0.43	-	0.77	0.64	0.45	-	0.79	0.66	0.46	-	0.82	0.69	0.48	-	0.83	0.69	0.48	-
	ΔT	19	16	12	-	19	16	12	-	19	16	12	-	19	17	13	-	19	16	12	-	18	15	12	-
	kW	2.27	2.32	2.38	-	2.43	2.47	2.54	-	2.56	2.61	2.68	-	2.68	2.73	2.81	-	2.78	2.83	2.91	-	2.86	2.92	3.01	-
	Amps	8.2	8.4	8.6	-	8.8	9.0	9.3	-	9.5	9.7	10.0	-	10.1	10.3	10.7	-	10.7	10.9	11.3	-	11.3	11.6	11.9	-
	HI PR	223	240	254	-	251	270	285	-	285	307	324	-	325	349	369	-	365	393	415	-	403	434	458	-
	LO PR	108	115	125	-	114	121	133	-	119	126	138	-	125	133	145	-	131	139	152	-	135	144	157	-
	MBh	33.3	34.5	37.8	-	32.5	33.7	36.9	-	31.7	32.9	36.1	-	31.0	32.1	35.2	-	29.4	30.5	33.4	-	27.3	28.3	31.0	-
	S/T	0.75	0.63	0.43	-	0.78	0.65	0.45	-	0.80	0.67	0.46	-	0.82	0.69	0.48	-	0.86	0.71	0.49	-	0.86	0.72	0.50	-
	ΔT	18	16	12	-	19	16	12	-	19	16	12	-	19	16	12	-	19	16	12	-	17	15	11	-
kW	2.32	2.37	2.43	-	2.48	2.53	2.60	-	2.62	2.67	2.74	-	2.74	2.79	2.87	-	2.84	2.90	2.98	-	2.93	2.99	3.08	-	
Amps	8.4	8.6	8.8	-	9.0	9.2	9.5	-	9.7	10.0	10.3	-	10.4	10.6	10.9	-	11.0	11.2	11.6	-	11.6	11.9	12.2	-	
HI PR	230	248	262	-	258	278	294	-	294	316	334	-	335	360	380	-	376	405	428	-	416	448	473	-	
LO PR	111	118	129	-	118	125	137	-	122	130	142	-	128	137	149	-	135	143	156	-	139	148	162	-	
MBh	34.3	35.5	38.9	-	33.5	34.7	38.0	-	32.7	33.9	37.1	-	31.9	33.1	36.2	-	30.3	31.4	34.4	-	28.1	29.1	31.9	-	
S/T	0.79	0.66	0.46	-	0.82	0.68	0.47	-	0.84	0.70	0.48	-	0.86	0.72	0.50	-	0.90	0.75	0.52	-	0.90	0.76	0.52	-	
ΔT	18	15	12	-	18	16	12	-	18	16	12	-	18	16	12	-	18	15	12	-	17	14	11	-	
kW	2.34	2.38	2.45	-	2.50	2.54	2.62	-	2.63	2.69	2.76	-	2.76	2.81	2.89	-	2.86	2.92	3.00	-	2.95	3.01	3.10	-	
Amps	8.5	8.7	8.9	-	9.1	9.3	9.6	-	9.8	10.1	10.4	-	10.5	10.7	11.0	-	11.1	11.3	11.7	-	11.7	12.0	12.4	-	
HI PR	233	250	264	-	261	281	296	-	297	319	337	-	338	364	384	-	380	409	432	-	420	452	477	-	
LO PR	112	120	131	-	119	126	138	-	123	131	143	-	130	138	151	-	136	145	158	-	141	150	163	-	

75	MBh	31.3	32.2	34.8	37.4	30.5	31.4	34.0	36.5	29.8	30.7	33.2	35.6	29.1	29.9	32.4	34.8	27.6	28.4	30.8	33.0	25.6	26.3	28.5	30.6
	S/T	0.82	0.74	0.56	0.36	0.85	0.76	0.58	0.37	0.87	0.78	0.59	0.38	0.90	0.81	0.61	0.39	0.94	0.84	0.63	0.41	0.95	0.85	0.64	0.41
	ΔT	22	20	16	11	22	20	17	11	22	20	17	11	22	20	17	12	22	20	16	11	20	19	15	11
	kW	2.29	2.33	2.40	2.46	2.44	2.49	2.56	2.63	2.58	2.63	2.70	2.78	2.70	2.75	2.83	2.91	2.80	2.85	2.94	3.03	2.88	2.94	3.03	3.12
	Amps	8.3	8.4	8.7	9.0	8.9	9.1	9.3	9.7	9.6	9.8	10.1	10.4	10.2	10.4	10.7	11.1	10.8	11.0	11.4	11.8	11.4	11.7	12.0	12.5
	HI PR	226	243	256	267	253	272	288	300	288	310	327	341	328	353	373	389	369	397	419	437	408	439	463	483
	LO PR	109	116	127	135	115	123	134	143	120	127	139	148	126	134	146	156	132	140	153	163	136	145	158	169
	MBh	33.9	34.9	37.7	40.5	33.1	34.1	36.9	39.6	32.3	33.2	36.0	38.6	31.5	32.4	35.1	37.7	29.9	30.8	33.3	35.8	27.7	28.5	30.9	33.2
	S/T	0.85	0.76	0.58	0.37	0.88	0.79	0.60	0.39	0.91	0.81	0.61	0.40	0.94	0.84	0.63	0.41	0.97	0.87	0.66	0.42	0.98	0.88	0.66	0.43
	ΔT	21	20	16	11	22	20	16	11	22	20	16	11	22	20	16	11	22	20	16	11	20	18	15	10
kW	2.34	2.38	2.45	2.52	2.50	2.54	2.62	2.69	2.63	2.69	2.76	2.85	2.76	2.81	2.89	2.98	2.86	2.92	3.00	3.10	2.95	3.01	3.10	3.20	
Amps	8.5	8.7	8.9	9.2	9.1	9.3	9.6	9.9	9.8	10.1	10.4	10.7	10.5	10.7	11.0	11.4	11.1	11.3	11.7	12.1	11.7	12.0	12.4	12.8	
HI PR	233	250	264	276	261	281	297	309	297	319	337	352	338	364	384	401	380	409	432	451	420	452	477	498	
LO PR	112	120	131	139	119	126	138	147	124	131	143	153	130	138	151	160	136	145	158	168	141	150	163	174	
MBh	34.9	35.9	38.9	41.7	34.1	35.1	38.0	40.7	33.3	34.2	37.1	39.8	32.4	33.4	36.2	38.8	30.8	31.7	34.4	36.9	28.6	29.4	31.8	34.2	
S/T	0.90	0.80	0.61	0.39	0.93	0.83	0.63	0.40	0.95	0.85	0.64	0.41	0.98	0.88	0.66	0.43	1.00	0.91	0.69	0.44	1.00	0.92	0.70	0.45	
ΔT	21	19	15	11	21	19	16	11	21	19	16	11	21	19	16	11	20	19	16	11	19	18	15	10	
kW	2.36	2.40	2.47	2.54	2.51	2.56	2.63	2.71	2.65	2.71	2.78	2.87	2.78	2.83	2.92	3.00	2.88	2.94	3.03	3.12	2.97	3.03	3.12	3.22	
Amps	8.5	8.7	9.0	9.3	9.2	9.4	9.7	10.0	9.9	10.1	10.5	10.8	10.5	10.8	11.1	11.5	11.2	11.4	11.8	12.2	11.8	12.1	12.5	12.9	
HI PR	235	253	267	278	264	284	300	312	300	323	341	355	341	367	388	405	384	413	436	455	424	457	482	503	
LO PR	114	121	132	141	120	128	139	148	125	133	145	154	131	139	152	162	137	146	159	170	142	151	165	176	

IDB: Entering Indoor Dry Bulb Temperature
 High and low pressures are measured at the liquid and suction service valves.
 Shaded area reflects ACCA (TVA) conditions
 kW = Total system power
 Amps = outdoor unit amps (compressor + fan)

EXPANDED COOLING DATA — ASZ140361B* / AR*F374316B* (CONT.)

IDB	AIRFLOW	OUTDOOR AMBIENT TEMPERATURE												ENTERING INDOOR WET BULB TEMPERATURE											
		65°F				75°F				85°F				95°F				105°F				115°F			
		59	63	67	71	59	63	67	71	59	63	67	71	59	63	67	71	59	63	67	71	59	63	67	71
1090	MBh	31.8	32.5	34.7	37.1	31.1	31.7	33.9	36.3	30.3	31.0	33.1	35.4	29.6	30.2	32.3	34.5	28.1	28.7	30.7	32.8	26.0	26.6	28.4	30.4
	S/T	0.90	0.85	0.69	0.52	0.94	0.88	0.71	0.53	0.96	0.90	0.73	0.55	0.99	0.93	0.76	0.57	1.03	0.96	0.78	0.59	1.04	0.97	0.79	0.59
	ΔT	24	23	20	16	25	24	20	16	25	24	20	16	25	24	21	16	24	23	20	16	23	22	19	15
	kW	2.31	2.35	2.41	2.48	2.46	2.51	2.58	2.65	2.60	2.65	2.72	2.80	2.72	2.77	2.85	2.94	2.82	2.87	2.96	3.05	2.91	2.96	3.05	3.15
	Amps	8.3	8.5	8.8	9.1	9.0	9.1	9.4	9.8	9.7	9.9	10.2	10.5	10.3	10.5	10.8	11.2	10.9	11.1	11.5	11.9	11.5	11.8	12.1	12.6
	HI PR	228	245	259	270	256	275	291	303	291	313	330	345	331	356	376	393	373	401	423	442	412	443	468	488
	LO PR	110	117	128	136	116	124	135	144	121	129	141	150	127	135	148	157	133	142	155	165	138	147	160	170
	MBh	34.5	35.2	37.6	40.2	33.7	34.4	36.8	39.3	32.9	33.6	35.9	38.4	32.1	32.8	35.0	37.4	30.5	31.1	33.3	35.5	28.2	28.8	30.8	32.9
	S/T	0.94	0.88	0.71	0.53	0.97	0.91	0.74	0.55	1.00	0.93	0.76	0.57	1.00	0.96	0.78	0.59	1.00	1.00	0.81	0.61	1.00	1.00	0.82	0.61
	ΔT	24	23	20	16	24	23	20	16	24	23	20	16	24	23	20	16	22	23	20	16	21	21	19	15
1250	kW	2.36	2.40	2.47	2.54	2.51	2.56	2.63	2.71	2.65	2.71	2.78	2.87	2.78	2.83	2.92	3.00	2.88	2.94	3.03	3.12	2.97	3.03	3.12	3.22
	Amps	8.5	8.7	9.0	9.3	9.2	9.4	9.7	10.0	9.9	10.1	10.5	10.8	10.5	10.8	11.1	11.5	11.2	11.4	11.8	12.2	11.8	12.1	12.5	12.9
	HI PR	235	253	267	278	264	284	300	312	300	323	341	355	341	367	388	405	384	413	437	455	424	457	482	503
	LO PR	114	121	132	141	120	128	139	148	125	133	145	154	131	139	152	162	137	146	160	170	142	151	165	176
	MBh	35.5	36.3	38.8	41.4	34.7	35.4	37.9	40.5	33.8	34.6	37.0	39.5	33.0	33.7	36.1	38.5	31.4	32.1	34.2	36.6	29.1	29.7	31.7	33.9
	S/T	1.00	0.92	0.75	0.56	1.00	0.95	0.78	0.58	1.00	1.00	0.80	0.60	1.00	1.00	0.82	0.61	1.00	1.00	0.85	0.64	1.00	1.00	0.86	0.64
	ΔT	23	22	19	15	23	22	19	15	22	23	19	15	22	22	19	16	21	21	19	15	19	19	18	14
	kW	2.37	2.42	2.48	2.55	2.53	2.58	2.65	2.73	2.67	2.73	2.80	2.89	2.80	2.85	2.94	3.03	2.90	2.96	3.05	3.14	3.00	3.06	3.15	3.25
	Amps	8.6	8.8	9.1	9.4	9.3	9.5	9.8	10.1	10.0	10.2	10.5	10.9	10.6	10.9	11.2	11.6	11.3	11.5	11.9	12.3	11.9	12.2	12.6	13.0
	HI PR	237	255	270	281	266	286	303	316	303	326	344	359	345	371	392	409	388	417	441	460	429	461	487	508
LO PR	115	122	133	143	121	129	141	150	126	134	146	156	132	141	154	164	139	148	161	172	143	153	167	177	

1090	MBh	32.4	33.0	34.6	36.9	31.6	32.2	33.8	36.0	30.9	31.5	32.9	35.1	30.1	30.7	32.1	34.3	28.6	29.2	30.5	32.6	26.5	27.0	28.3	30.2
	S/T	0.95	0.91	0.82	0.67	0.98	0.95	0.85	0.69	1.00	0.97	0.88	0.71	1.00	1.00	0.90	0.73	1.00	1.00	0.94	0.76	1.00	1.00	0.95	0.77
	ΔT	26	25	24	21	26	26	24	21	26	26	24	21	25	26	25	21	24	25	24	21	22	23	23	20
	kW	2.32	2.37	2.43	2.50	2.48	2.52	2.60	2.67	2.61	2.67	2.74	2.82	2.74	2.79	2.87	2.96	2.84	2.90	2.98	3.07	2.93	2.99	3.08	3.17
	Amps	8.4	8.6	8.8	9.1	9.0	9.2	9.5	9.8	9.7	10.0	10.3	10.6	10.4	10.6	10.9	11.3	11.0	11.2	11.6	12.0	11.6	11.9	12.2	12.7
	HI PR	230	248	262	273	258	278	293	306	294	316	334	348	335	360	380	396	376	405	428	446	416	447	472	493
	LO PR	111	118	129	138	118	125	137	145	122	130	142	151	128	137	149	159	135	143	156	166	139	148	162	172
	MBh	35.1	35.7	37.4	39.9	34.3	34.9	36.6	39.0	33.4	34.1	35.7	38.1	32.6	33.3	34.8	37.2	31.0	31.6	33.1	35.3	28.7	29.3	30.6	32.7
	S/T	0.98	0.95	0.85	0.69	1.00	0.98	0.89	0.72	1.00	1.00	0.91	0.74	1.00	1.00	0.94	0.76	1.00	1.00	0.97	0.79	1.00	1.00	0.98	0.80
	ΔT	25	25	24	20	25	25	24	21	25	25	24	21	24	24	24	21	23	23	24	20	21	22	22	19
1250	kW	2.37	2.42	2.48	2.55	2.53	2.58	2.65	2.73	2.67	2.73	2.80	2.89	2.80	2.85	2.94	3.03	2.90	2.96	3.05	3.14	3.00	3.06	3.15	3.25
	Amps	8.6	8.8	9.1	9.4	9.3	9.5	9.8	10.1	10.0	10.2	10.5	10.9	10.6	10.9	11.2	11.6	11.3	11.5	11.9	12.3	11.9	12.2	12.6	13.0
	HI PR	237	255	270	281	266	286	303	316	303	326	344	359	345	371	392	409	388	417	441	460	429	461	487	508
	LO PR	115	122	133	142	121	129	141	150	126	134	146	156	132	141	154	164	139	148	161	172	143	153	167	177
	MBh	36.1	36.8	38.6	41.1	35.3	36.0	37.7	40.2	34.4	35.1	36.8	39.2	33.6	34.2	35.9	38.3	31.9	32.5	34.1	36.4	29.6	30.1	31.6	33.7
	S/T	1.00	0.99	0.90	0.73	1.00	1.00	0.93	0.75	1.00	1.00	0.95	0.77	1.00	1.00	0.98	0.80	1.00	1.00	1.00	0.83	1.00	1.00	1.00	0.83
	ΔT	24	24	23	20	23	24	23	20	23	23	23	20	22	22	23	20	21	21	22	20	19	20	21	18
	kW	2.39	2.43	2.50	2.57	2.55	2.60	2.67	2.75	2.69	2.75	2.83	2.91	2.82	2.87	2.96	3.05	2.93	2.98	3.07	3.17	3.02	3.08	3.17	3.27
	Amps	8.7	8.9	9.1	9.5	9.3	9.5	9.8	10.2	10.1	10.3	10.6	11.0	10.7	11.0	11.3	11.7	11.4	11.6	12.0	12.4	12.0	12.3	12.7	13.1
	HI PR	240	258	272	284	269	289	306	319	306	329	348	362	348	375	396	413	392	422	445	464	433	466	492	513
LO PR	116	123	135	143	122	130	142	151	127	135	148	157	134	142	155	165	140	149	163	173	145	154	168	179	

IDB: Entering Indoor Dry Bulb Temperature
 High and low pressures are measured at the liquid and suction service valves.
 Shaded area reflects AHRI (TVA) conditions
 Amps = outdoor unit amps (compressor + fan)
 kW = Total system power

EXPANDED COOLING DATA — ASZ140421A* / CA*F4860*6A*+TXV / MBR2000** -1

IDB	AIRFLOW	OUTDOOR AMBIENT TEMPERATURE																							
		65°F				75°F				85°F				95°F				105°F				115°F			
		59	63	67	71	59	63	67	71	59	63	67	71	59	63	67	71	59	63	67	71	59	63	67	71
	MBh	39.2	40.6	44.5	-	38.3	39.7	43.5	-	37.4	38.7	42.4	-	36.5	37.8	41.4	-	34.6	35.9	39.3	-	32.1	33.3	36.4	-
	S/T	0.77	0.65	0.45	-	0.80	0.67	0.46	-	0.82	0.69	0.48	-	0.85	0.71	0.49	-	0.88	0.74	0.51	-	0.89	0.74	0.51	-
	ΔT	18	15	12	-	18	16	12	-	18	16	12	-	18	16	12	-	18	15	12	-	17	14	11	-
1575	kW	2.65	2.71	2.78	-	2.84	2.90	2.98	-	3.01	3.07	3.16	-	3.15	3.22	3.31	-	3.28	3.34	3.45	-	3.38	3.45	3.56	-
	Amps	9.7	9.9	10.2	-	10.4	10.7	11.0	-	11.3	11.6	12.0	-	12.1	12.4	12.8	-	12.8	13.1	13.6	-	13.6	13.9	14.4	-
	Hi/PR	218	234	247	-	244	263	277	-	278	299	315	-	316	340	359	-	356	383	404	-	393	423	447	-
	Lo/PR	107	114	125	-	113	121	132	-	118	125	137	-	124	132	144	-	130	138	151	-	134	143	156	-
	MBh	38.1	39.4	43.2	-	37.2	38.5	42.2	-	36.3	37.6	41.2	-	35.4	36.7	40.2	-	33.6	34.9	38.2	-	31.2	32.3	35.4	-
	S/T	0.74	0.62	0.43	-	0.77	0.64	0.44	-	0.79	0.66	0.45	-	0.81	0.68	0.47	-	0.84	0.70	0.49	-	0.85	0.71	0.49	-
	ΔT	18	16	12	-	19	16	12	-	19	16	12	-	19	16	12	-	19	16	12	-	17	15	11	-
70	kW	2.63	2.69	2.76	-	2.82	2.88	2.96	-	2.98	3.04	3.14	-	3.13	3.19	3.29	-	3.25	3.32	3.42	-	3.36	3.43	3.53	-
	Amps	9.6	9.8	10.1	-	10.4	10.6	10.9	-	11.2	11.5	11.8	-	12.0	12.2	12.6	-	12.7	13.0	13.4	-	13.4	13.8	14.2	-
	Hi/PR	215	232	245	-	242	260	275	-	275	296	312	-	313	337	356	-	352	379	400	-	389	419	442	-
	Lo/PR	106	113	123	-	112	120	130	-	117	124	136	-	123	130	142	-	129	137	149	-	133	141	154	-
	MBh	35.1	36.4	39.9	-	34.3	35.6	39.0	-	33.5	34.7	38.0	-	32.7	33.9	37.1	-	31.0	32.2	35.2	-	28.8	29.8	32.7	-
	S/T	0.71	0.59	0.41	-	0.74	0.62	0.43	-	0.76	0.63	0.44	-	0.78	0.65	0.45	-	0.81	0.68	0.47	-	0.82	0.68	0.47	-
	ΔT	19	16	12	-	19	16	12	-	19	16	13	-	19	17	13	-	19	16	12	-	18	15	12	-
1225	kW	2.58	2.63	2.70	-	2.76	2.81	2.89	-	2.92	2.97	3.06	-	3.06	3.12	3.21	-	3.17	3.24	3.34	-	3.28	3.35	3.45	-
	Amps	9.4	9.6	9.9	-	10.1	10.3	10.6	-	10.9	11.2	11.5	-	11.6	11.9	12.3	-	12.4	12.7	13.1	-	13.1	13.4	13.8	-
	Hi/PR	209	225	237	-	234	252	266	-	267	287	303	-	304	327	345	-	342	368	388	-	377	406	429	-
	Lo/PR	103	110	120	-	109	116	127	-	113	120	132	-	119	127	138	-	125	133	145	-	129	137	150	-

	MBh	39.9	41.0	44.4	47.7	38.9	40.1	43.4	46.6	38.0	39.1	42.4	45.5	37.1	38.2	41.3	44.4	35.2	36.3	39.3	42.1	32.6	33.6	36.4	39.0
	S/T	0.88	0.79	0.60	0.38	0.91	0.82	0.62	0.40	0.94	0.84	0.63	0.41	0.97	0.86	0.65	0.42	1.00	0.90	0.68	0.44	1.00	0.90	0.68	0.44
	ΔT	20	19	15	11	21	19	16	11	21	19	16	11	21	19	16	11	21	19	16	11	19	18	15	10
1575	kW	2.67	2.73	2.80	2.89	2.86	2.92	3.01	3.10	3.03	3.09	3.18	3.28	3.18	3.24	3.34	3.45	3.30	3.37	3.47	3.58	3.41	3.48	3.59	3.70
	Amps	9.8	10.0	10.3	10.7	10.5	10.8	11.1	11.5	11.4	11.7	12.1	12.5	12.2	12.5	12.9	13.3	12.9	13.3	13.7	14.2	13.7	14.0	14.5	15.0
	Hi/PR	220	236	250	260	247	265	280	292	280	302	319	332	319	344	363	379	359	387	408	426	397	427	451	471
	Lo/PR	108	115	126	134	115	122	133	142	119	127	138	147	125	133	145	155	131	140	152	162	136	144	158	168
	MBh	38.7	39.8	43.1	46.3	37.8	38.9	42.1	45.2	36.9	38.0	41.1	44.1	36.0	37.1	40.1	43.1	34.2	35.2	38.1	40.9	31.7	32.6	35.3	37.9
	S/T	0.84	0.75	0.57	0.37	0.87	0.78	0.59	0.38	0.89	0.80	0.60	0.39	0.92	0.82	0.62	0.40	0.96	0.86	0.65	0.42	0.96	0.86	0.65	0.42
	ΔT	21	20	16	11	22	20	16	11	22	20	16	11	22	20	16	11	21	20	16	11	20	18	15	10
1400	kW	2.65	2.71	2.78	2.87	2.84	2.90	2.98	3.07	3.01	3.07	3.16	3.26	3.15	3.22	3.32	3.42	3.28	3.34	3.45	3.56	3.38	3.45	3.56	3.68
	Amps	9.7	9.9	10.2	10.6	10.4	10.7	11.0	11.4	11.3	11.6	12.0	12.4	12.1	12.4	12.8	13.2	12.8	13.1	13.6	14.1	13.6	13.9	14.4	14.9
	Hi/PR	218	234	247	258	244	263	277	289	278	299	316	329	316	340	359	375	356	383	404	422	393	423	447	466
	Lo/PR	107	114	125	133	113	121	132	140	118	125	137	146	124	132	144	153	130	138	151	161	134	143	156	166
	MBh	35.7	36.8	39.8	42.7	34.9	35.9	38.9	41.7	34.1	35.1	38.0	40.7	33.2	34.2	37.0	39.7	31.6	32.5	35.2	37.8	29.2	30.1	32.6	35.0
	S/T	0.81	0.72	0.55	0.35	0.84	0.75	0.57	0.37	0.86	0.77	0.58	0.37	0.89	0.79	0.60	0.39	0.92	0.82	0.62	0.40	0.93	0.83	0.63	0.40
	ΔT	22	20	16	11	22	20	17	11	22	20	17	11	22	20	17	12	22	20	16	11	20	19	15	11
1225	kW	2.60	2.65	2.72	2.80	2.78	2.83	2.92	3.00	2.94	3.00	3.09	3.18	3.08	3.14	3.24	3.34	3.20	3.27	3.37	3.47	3.30	3.37	3.48	3.59
	Amps	9.4	9.7	10.0	10.3	10.2	10.4	10.7	11.1	11.0	11.3	11.6	12.1	11.7	12.0	12.4	12.9	12.5	12.8	13.2	13.7	13.2	13.5	14.0	14.5
	Hi/PR	211	227	240	250	237	255	269	281	269	290	306	319	307	330	349	364	345	371	392	409	381	410	433	452
	Lo/PR	104	111	121	129	110	117	128	136	114	122	133	142	120	128	140	149	126	134	146	156	130	139	151	161

IDB: Entering Indoor Dry Bulb Temperature Shaded area reflects ACCA (TVA) conditions kW=Total system power Amps = outdoor unit amps (comp.+fan)

EXPANDED COOLING DATA — AS2140421A* / CA*F4860*6A* +TXV / MBR2000** -1 (CONT.)

IDB	AIRFLOW	OUTDOOR AMBIENT TEMPERATURE																							
		65°F				75°F				85°F				95°F				105°F				115°F			
		59	63	67	71	59	63	67	71	59	63	67	71	59	63	67	71	59	63	67	71	59	63	67	71
80	MBh	40.6	41.5	44.3	47.3	39.6	40.5	43.3	46.2	38.7	39.5	42.2	45.1	37.7	38.6	41.2	44.0	35.9	36.6	39.1	41.8	33.2	33.9	36.3	38.8
	S/T	0.97	0.91	0.74	0.55	1.00	0.94	0.76	0.57	1.00	0.96	0.78	0.59	1.00	1.00	0.81	0.60	1.00	1.00	0.84	0.63	1.00	1.00	0.85	0.63
	ΔT	23	22	19	15	23	22	19	15	22	23	19	15	22	23	19	16	21	21	19	15	19	20	18	14
	kW	2.69	2.75	2.83	2.91	2.88	2.94	3.03	3.12	3.05	3.11	3.21	3.31	3.20	3.27	3.37	3.47	3.33	3.40	3.50	3.61	3.44	3.51	3.62	3.73
	Amps	9.9	10.1	10.4	10.8	10.6	10.9	11.2	11.6	11.5	11.8	12.2	12.6	12.3	12.6	13.0	13.5	13.1	13.4	13.8	14.3	13.8	14.2	14.6	15.2
	Hi PR	222	239	252	263	249	268	283	295	283	305	322	336	323	347	367	382	363	391	412	430	401	432	456	475
	Lo PR	110	117	127	136	116	123	134	143	120	128	140	149	126	134	147	156	132	141	154	164	137	146	159	169
	MBh	39.4	40.2	43.0	46.0	38.5	39.3	42.0	44.9	37.6	38.4	41.0	43.8	36.6	37.4	40.0	42.8	34.8	35.6	38.0	40.6	32.2	32.9	35.2	37.6
	S/T	0.92	0.86	0.70	0.53	0.95	0.90	0.73	0.54	0.98	0.92	0.75	0.56	1.00	0.95	0.77	0.58	1.00	0.98	0.80	0.60	1.00	0.99	0.81	0.60
	ΔT	24	23	20	16	24	23	20	16	24	23	20	16	24	23	20	16	23	23	20	16	21	21	19	15
kW	2.67	2.73	2.80	2.89	2.86	2.92	3.01	3.10	3.03	3.09	3.18	3.28	3.18	3.24	3.34	3.45	3.30	3.37	3.48	3.59	3.41	3.48	3.59	3.71	
Amps	9.8	10.0	10.3	10.7	10.5	10.8	11.1	11.5	11.4	11.7	12.1	12.5	12.2	12.5	12.9	13.3	12.9	13.3	13.7	14.2	13.7	14.0	14.5	15.0	
Hi PR	220	237	250	260	247	265	280	292	280	302	319	332	319	344	363	379	359	387	408	426	397	427	451	471	
Lo PR	109	115	126	134	115	122	133	142	119	127	138	147	125	133	145	155	131	140	152	162	136	144	158	168	
MBh	36.4	37.1	39.7	42.4	35.5	36.3	38.8	41.4	34.7	35.4	37.8	40.5	33.8	34.6	36.9	39.5	32.1	32.8	35.1	37.5	29.8	30.4	32.5	34.7	
S/T	0.89	0.83	0.68	0.51	0.92	0.86	0.70	0.53	0.94	0.89	0.72	0.54	0.97	0.91	0.74	0.56	1.01	0.95	0.77	0.58	1.02	0.96	0.78	0.58	
ΔT	24	23	20	16	25	24	20	16	25	24	20	16	25	24	21	16	24	23	20	16	23	22	19	15	
kW	2.61	2.67	2.74	2.82	2.80	2.85	2.94	3.03	2.96	3.02	3.11	3.21	3.10	3.17	3.26	3.36	3.22	3.29	3.39	3.50	3.33	3.40	3.50	3.62	
Amps	9.5	9.7	10.0	10.4	10.3	10.5	10.8	11.2	11.1	11.4	11.7	12.2	11.9	12.1	12.5	13.0	12.6	12.9	13.3	13.8	13.3	13.6	14.1	14.6	
Hi PR	213	229	242	253	239	257	272	284	272	293	309	322	310	333	352	367	349	375	396	413	385	414	438	456	
Lo PR	105	112	122	130	111	118	129	138	116	123	134	143	121	129	141	150	127	135	148	157	132	140	153	163	

85	MBh	41.3	42.1	44.1	47.0	40.3	41.1	43.0	45.9	39.4	40.1	42.0	44.8	38.4	39.1	41.0	43.7	36.5	37.2	38.9	41.5	33.8	34.4	36.1	38.5
	S/T	1.00	0.98	0.88	0.72	1.00	1.00	0.91	0.74	1.00	1.00	0.94	0.76	1.00	1.00	0.97	0.78	1.00	1.00	0.96	0.78	1.00	1.00	0.97	0.82
	ΔT	24	24	23	20	24	24	23	20	23	23	23	20	22	23	23	20	21	22	23	20	20	20	21	18
	kW	2.71	2.77	2.85	2.93	2.91	2.96	3.05	3.15	3.08	3.14	3.23	3.33	3.23	3.29	3.39	3.50	3.35	3.42	3.53	3.64	3.46	3.54	3.65	3.76
	Amps	9.9	10.2	10.5	10.9	10.7	11.0	11.3	11.7	11.6	11.9	12.3	12.7	12.4	12.7	13.1	13.6	13.2	13.5	13.9	14.5	13.9	14.3	14.8	15.3
	Hi PR	224	241	255	266	252	271	286	298	286	308	325	339	326	351	370	386	367	395	417	434	405	436	460	480
	Lo PR	111	118	129	137	117	124	136	145	122	129	141	150	128	136	148	158	134	142	155	165	138	147	161	171
	MBh	40.1	40.9	42.8	45.6	39.1	39.9	41.8	44.6	38.2	39.0	40.8	43.5	37.3	38.0	39.8	42.5	35.4	36.1	37.8	40.3	32.8	33.4	35.0	37.4
	S/T	0.97	0.93	0.84	0.68	1.00	0.97	0.87	0.71	1.00	0.99	0.89	0.72	1.00	1.00	0.92	0.75	1.00	1.00	0.96	0.78	1.00	1.00	0.97	0.78
	ΔT	25	25	24	20	26	25	24	21	25	25	24	21	24	24	24	21	23	24	24	21	22	22	22	19
kW	2.69	2.75	2.83	2.91	2.88	2.94	3.03	3.12	3.05	3.11	3.21	3.31	3.20	3.27	3.37	3.47	3.33	3.40	3.50	3.61	3.44	3.51	3.62	3.73	
Amps	9.9	10.1	10.4	10.8	10.6	10.9	11.2	11.6	11.5	11.8	12.2	12.6	12.3	12.6	13.0	13.5	13.1	13.4	13.8	14.3	13.8	14.2	14.6	15.2	
Hi PR	222	239	252	263	249	268	283	295	283	305	322	336	323	347	367	382	363	391	412	430	401	432	456	475	
Lo PR	110	117	127	136	116	123	134	143	120	128	140	149	126	134	147	156	132	141	154	164	137	146	159	169	
MBh	37.0	37.7	39.5	42.1	36.1	36.8	38.6	41.2	35.3	36.0	37.7	40.2	34.4	35.1	36.7	39.2	32.7	33.3	34.9	37.2	30.3	30.9	32.3	34.5	
S/T	0.93	0.90	0.81	0.66	0.96	0.93	0.84	0.68	0.99	0.95	0.86	0.70	1.00	0.99	0.89	0.72	1.00	1.00	0.92	0.75	1.00	1.00	0.93	0.76	
ΔT	26	25	24	21	26	26	24	21	26	26	24	21	26	26	25	21	25	25	24	21	23	23	23	20	
kW	2.63	2.68	2.76	2.84	2.82	2.87	2.96	3.05	2.98	3.04	3.13	3.23	3.13	3.19	3.29	3.39	3.25	3.32	3.42	3.53	3.36	3.43	3.53	3.64	
Amps	9.6	9.8	10.1	10.5	10.3	10.6	10.9	11.3	11.2	11.5	11.8	12.3	12.0	12.2	12.6	13.1	12.7	13.0	13.4	13.9	13.4	13.8	14.2	14.7	
Hi PR	215	232	245	255	242	260	275	286	275	296	312	326	313	337	356	371	352	379	400	417	389	419	442	461	
Lo PR	106	113	123	131	112	119	130	139	117	124	136	144	123	130	142	152	128	137	149	159	133	141	154	164	

IDB: Entering Indoor Dry Bulb Temperature Shaded area reflects AHRI conditions kW=Total system power Amps = outdoor unit amps (comp.+fan)

EXPANDED COOLING DATA — AS2140481A* / CA*F4860*6A* +TXV / MBR2000** -1

IDB	AIRFLOW	OUTDOOR AMBIENT TEMPERATURE												ENTERING INDOOR WET BULB TEMPERATURE											
		65°F				75°F				85°F				95°F				105°F				115°F			
		59	63	67	71	59	63	67	71	59	63	67	71	59	63	67	71	59	63	67	71	59	63	67	71
70	MBh	45.1	46.7	51.2	-	44.0	45.6	50.0	-	43.0	44.5	48.8	-	41.9	43.5	47.6	-	39.8	41.3	45.2	-	36.9	38.2	41.9	-
	S/T	0.76	0.64	0.44	-	0.79	0.66	0.46	-	0.81	0.68	0.47	-	0.84	0.70	0.48	-	0.87	0.73	0.50	-	0.88	0.73	0.51	-
	ΔT	18	16	12	-	18	16	12	-	18	16	12	-	18	16	12	-	18	16	12	-	17	15	11	-
	kW	2.98	3.04	3.13	-	3.19	3.26	3.36	-	3.38	3.45	3.56	-	3.55	3.62	3.73	-	3.69	3.77	3.88	-	3.81	3.89	4.01	-
	Amps	5.9	6.2	6.5	-	6.8	7.0	7.4	-	7.7	8.0	8.5	-	8.6	8.9	9.4	-	9.5	9.8	10.3	-	10.3	10.7	11.2	-
	Hi PR	217	233	247	-	243	262	277	-	277	298	315	-	315	339	358	-	355	382	403	-	392	422	445	-
	Lo PR	106	113	123	-	112	119	130	-	116	124	135	-	122	130	142	-	128	136	149	-	132	141	154	-
	MBh	43.8	45.4	49.7	-	42.7	44.3	48.5	-	41.7	43.2	47.4	-	40.7	42.2	46.2	-	38.7	40.1	43.9	-	35.8	37.1	40.7	-
	S/T	0.73	0.61	0.42	-	0.75	0.63	0.44	-	0.77	0.65	0.45	-	0.80	0.67	0.46	-	0.83	0.69	0.48	-	0.84	0.70	0.48	-
	ΔT	19	16	12	-	19	17	13	-	19	17	13	-	19	17	13	-	19	16	12	-	18	15	12	-
kW	2.96	3.02	3.10	-	3.17	3.23	3.33	-	3.36	3.42	3.53	-	3.52	3.59	3.70	-	3.66	3.74	3.85	-	3.78	3.86	3.98	-	
Amps	5.8	6.1	6.4	-	6.7	6.9	7.3	-	7.6	7.9	8.4	-	8.5	8.8	9.3	-	9.3	9.7	10.2	-	10.2	10.5	11.0	-	
Hi PR	215	231	244	-	241	259	274	-	274	295	311	-	312	336	355	-	351	378	399	-	388	418	441	-	
Lo PR	105	112	122	-	111	118	129	-	115	122	134	-	121	129	140	-	127	135	147	-	131	139	152	-	
MBh	40.4	41.9	45.9	-	39.5	40.9	44.8	-	38.5	39.9	43.7	-	37.6	38.9	42.7	-	35.7	37.0	40.5	-	33.1	34.3	37.5	-	
S/T	0.70	0.59	0.41	-	0.73	0.61	0.42	-	0.75	0.62	0.43	-	0.77	0.64	0.45	-	0.80	0.67	0.46	-	0.81	0.67	0.47	-	
ΔT	19	17	13	-	19	17	13	-	19	17	13	-	20	17	13	-	20	17	13	-	18	16	12	-	
kW	2.89	2.95	3.04	-	3.10	3.16	3.25	-	3.28	3.34	3.45	-	3.44	3.51	3.62	-	3.57	3.65	3.76	-	3.69	3.77	3.89	-	
Amps	5.5	5.8	6.1	-	6.3	6.6	7.0	-	7.3	7.6	8.0	-	8.1	8.4	8.9	-	8.9	9.3	9.7	-	9.7	10.1	10.6	-	
Hi PR	208	224	237	-	234	252	266	-	266	286	302	-	303	326	344	-	341	367	387	-	376	405	428	-	
Lo PR	102	108	118	-	107	114	125	-	112	119	130	-	117	125	136	-	123	131	143	-	127	135	148	-	

75	MBh	45.8	47.2	51.1	54.8	44.8	46.1	49.9	53.6	43.7	45.0	48.7	52.3	42.6	43.9	47.5	51.0	40.5	41.7	45.1	48.5	37.5	38.6	41.8	44.9
	S/T	0.87	0.78	0.59	0.38	0.90	0.80	0.61	0.39	0.92	0.82	0.62	0.40	0.95	0.85	0.64	0.41	0.99	0.88	0.67	0.43	1.00	0.89	0.67	0.43
	ΔT	21	19	16	11	21	20	16	11	21	20	16	11	21	20	16	11	21	19	16	11	20	18	15	10
	kW	3.00	3.06	3.15	3.25	3.22	3.28	3.38	3.49	3.41	3.48	3.58	3.70	3.58	3.65	3.76	3.88	3.72	3.80	3.92	4.04	3.84	3.92	4.05	4.18
	Amps	6.0	6.3	6.6	7.0	6.9	7.1	7.5	8.0	7.9	8.2	8.6	9.1	8.7	9.1	9.5	10.0	9.6	9.9	10.4	11.0	10.4	10.8	11.3	11.9
	Hi PR	219	236	249	260	246	265	279	291	280	301	318	331	319	343	362	378	358	386	407	425	396	426	450	469
	Lo PR	107	114	124	132	113	120	131	140	117	125	136	145	123	131	143	153	129	138	150	160	134	142	155	165
	MBh	44.5	45.8	49.6	53.2	43.5	44.8	48.4	52.0	42.4	43.7	47.3	50.8	41.4	42.6	46.1	49.5	39.3	40.5	43.8	47.0	36.4	37.5	40.6	43.6
	S/T	0.83	0.74	0.56	0.36	0.86	0.77	0.58	0.37	0.88	0.79	0.59	0.38	0.91	0.81	0.61	0.40	0.94	0.84	0.64	0.41	0.95	0.85	0.64	0.41
	ΔT	22	20	16	11	22	20	17	12	22	20	17	12	22	21	17	12	22	20	17	11	21	19	15	11
kW	2.98	3.04	3.13	3.22	3.19	3.26	3.36	3.46	3.38	3.45	3.56	3.67	3.55	3.62	3.73	3.85	3.69	3.77	3.88	4.01	3.81	3.89	4.01	4.14	
Amps	5.9	6.2	6.5	6.9	6.8	7.0	7.4	7.9	7.7	8.1	8.5	9.0	8.6	8.9	9.4	9.9	9.5	9.8	10.3	10.9	10.3	10.7	11.2	11.8	
Hi PR	217	233	247	257	243	262	277	289	277	298	315	328	315	339	358	374	355	382	403	421	392	422	445	465	
Lo PR	106	113	123	131	112	119	130	138	116	124	135	144	122	130	142	151	128	136	149	158	132	141	154	164	
MBh	41.1	42.3	45.8	49.1	40.1	41.3	44.7	48.0	39.2	40.3	43.7	46.8	38.2	39.3	42.6	45.7	36.3	37.4	40.5	43.4	33.6	34.6	37.5	40.2	
S/T	0.80	0.71	0.54	0.35	0.83	0.74	0.56	0.36	0.85	0.76	0.57	0.37	0.87	0.78	0.59	0.38	0.91	0.81	0.61	0.40	0.92	0.82	0.62	0.40	
ΔT	22	20	17	12	22	21	17	12	22	21	17	12	23	21	17	12	22	21	17	12	21	19	16	11	
kW	2.91	2.97	3.06	3.15	3.12	3.18	3.28	3.38	3.30	3.37	3.47	3.58	3.46	3.54	3.65	3.76	3.60	3.68	3.79	3.91	3.72	3.80	3.92	4.04	
Amps	5.6	5.9	6.2	6.6	6.4	6.7	7.1	7.5	7.4	7.7	8.1	8.6	8.2	8.6	9.0	9.5	9.1	9.4	9.9	10.4	9.9	10.2	10.7	11.3	
Hi PR	210	226	239	249	236	254	268	280	269	289	305	318	306	329	348	363	344	370	391	408	380	409	432	451	
Lo PR	103	109	119	127	109	115	126	134	113	120	131	140	118	126	138	147	124	132	144	154	128	137	149	159	

IDB: Entering Indoor Dry Bulb Temperature Shaded area reflects ACCA (TVA) conditions kW=Total system power Amps = outdoor unit amps (comp.+fan)

EXPANDED COOLING DATA — ASZ140481A* / CA*F4860*6A* +TXV / MBR2000** -1 (CONT.)

IDB	OUTDOOR AMBIENT TEMPERATURE												ENTERING INDOOR WET BULB TEMPERATURE												
	65°F				75°F				85°F				95°F				105°F				115°F				
	59	63	67	71	59	63	67	71	59	63	67	71	59	63	67	71	59	63	67	71	59	63	67	71	
1744	AIRFLOW	59	63	67	71	59	63	67	71	59	63	67	71	59	63	67	71	59	63	67	71	59	63	67	71
	MBh	46.7	47.7	50.9	54.4	45.6	46.6	49.7	53.2	44.5	45.5	48.6	51.9	43.4	44.3	47.4	50.6	41.2	42.1	45.0	48.1	38.2	39.0	41.7	44.6
	S/T	0.95	0.89	0.73	0.54	1.00	0.92	0.75	0.56	1.00	0.95	0.77	0.58	1.00	1.00	0.80	0.60	1.00	1.00	0.83	0.62	1.00	1.00	0.83	0.62
	ΔT	23	22	19	16	24	23	20	16	23	23	20	16	23	23	20	16	22	22	20	16	20	21	18	15
	kW	3.03	3.08	3.18	3.27	3.24	3.31	3.41	3.51	3.43	3.51	3.61	3.73	3.60	3.68	3.79	3.91	3.75	3.83	3.95	4.07	3.87	3.95	4.08	4.21
	Amps	6.1	6.4	6.7	7.1	7.0	7.3	7.6	8.1	8.0	8.3	8.7	9.2	8.8	9.2	9.6	10.2	9.7	10.1	10.6	11.2	10.6	11.0	11.5	12.1
	Hi PR	221	238	252	262	248	267	282	294	282	304	321	335	322	346	366	381	362	390	411	429	400	430	454	474
	Lo PR	108	115	125	134	114	121	133	141	119	126	138	147	125	133	145	154	131	139	152	162	135	144	157	167
	MBh	45.3	46.3	49.5	52.9	44.2	45.2	48.3	51.6	43.2	44.1	47.2	50.4	42.1	43.1	46.0	49.2	40.0	40.9	43.7	46.7	37.1	37.9	40.5	43.3
	S/T	0.91	0.85	0.69	0.52	0.94	0.88	0.72	0.54	0.96	0.90	0.74	0.55	0.99	0.93	0.76	0.57	1.00	0.97	0.79	0.59	1.00	0.98	0.79	0.59
ΔT	24	23	20	16	25	24	21	16	25	24	21	16	25	24	21	17	24	23	20	16	22	22	19	15	
80	kW	3.00	3.06	3.15	3.25	3.22	3.28	3.38	3.49	3.41	3.48	3.58	3.70	3.58	3.65	3.76	3.88	3.72	3.80	3.92	4.04	3.84	3.92	4.05	4.18
	Amps	6.0	6.3	6.6	7.0	6.9	7.1	7.5	8.0	7.9	8.2	8.6	9.1	8.7	9.1	9.5	10.1	9.6	9.9	10.4	11.0	10.4	10.8	11.3	11.9
	Hi PR	219	236	249	260	246	265	279	291	280	301	318	332	319	343	362	378	358	386	407	425	396	426	450	469
	Lo PR	107	114	124	132	113	120	131	140	117	125	136	145	123	131	143	153	129	138	150	160	134	142	155	165
	MBh	41.8	42.7	45.6	48.8	40.8	41.7	44.6	47.7	39.9	40.7	43.5	46.5	38.9	39.7	42.5	45.4	36.9	37.8	40.3	43.1	34.2	35.0	37.4	39.9
	S/T	0.87	0.82	0.67	0.50	0.91	0.85	0.69	0.52	0.93	0.87	0.71	0.53	0.96	0.90	0.73	0.55	1.00	0.93	0.76	0.57	1.00	0.94	0.77	0.57
	ΔT	25	24	21	17	25	24	21	17	25	24	21	17	25	24	21	17	25	24	21	17	23	22	19	16
	kW	2.94	2.99	3.08	3.17	3.14	3.21	3.30	3.40	3.33	3.40	3.50	3.61	3.49	3.56	3.67	3.79	3.63	3.71	3.82	3.94	3.75	3.83	3.95	4.08
	Amps	5.7	6.0	6.3	6.7	6.6	6.8	7.2	7.6	7.5	7.8	8.2	8.7	8.4	8.7	9.1	9.6	9.2	9.5	10.0	10.6	10.0	10.4	10.9	11.5
	Hi PR	213	229	242	252	239	257	271	283	271	292	308	322	309	333	351	366	348	374	395	412	384	413	436	455
Lo PR	104	110	121	128	110	117	127	136	114	121	132	141	120	127	139	148	125	133	146	155	130	138	151	160	

1744	MBh	47.5	48.4	50.7	54.1	46.4	47.3	49.5	52.8	45.3	46.1	48.3	51.6	44.2	45.0	47.1	50.3	42.0	42.8	44.8	47.8	38.9	39.6	41.5	44.3
	S/T	1.00	0.96	0.87	0.70	1.00	1.00	0.90	0.73	1.00	1.00	0.92	0.75	1.00	1.00	0.95	0.77	1.00	1.00	0.99	0.80	1.00	1.00	1.00	0.81
	ΔT	25	25	23	20	24	25	23	20	24	24	24	20	23	24	24	20	22	23	23	20	20	21	22	19
	kW	3.05	3.11	3.20	3.30	3.27	3.33	3.43	3.54	3.46	3.53	3.64	3.76	3.63	3.71	3.82	3.95	3.78	3.86	3.98	4.11	3.90	3.99	4.11	4.25
	Amps	6.2	6.5	6.8	7.2	7.1	7.4	7.8	8.2	8.1	8.4	8.8	9.4	9.0	9.3	9.8	10.3	9.9	10.2	10.7	11.3	10.7	11.1	11.6	12.3
	Hi PR	224	241	254	265	251	270	285	297	285	307	324	338	325	350	369	385	366	393	415	433	404	435	459	479
	Lo PR	109	116	127	135	115	123	134	143	120	127	139	148	126	134	146	156	132	140	153	163	136	145	158	169
	MBh	46.1	47.0	49.2	52.5	45.0	45.9	48.1	51.3	43.9	44.8	46.9	50.1	42.9	43.7	45.8	48.8	40.7	41.5	43.5	46.4	37.7	38.5	40.3	43.0
	S/T	0.95	0.92	0.83	0.67	0.99	0.95	0.86	0.70	1.00	0.97	0.88	0.71	1.00	1.00	0.91	0.74	1.00	1.00	0.94	0.76	1.00	1.00	0.95	0.77
	ΔT	26	26	24	21	26	26	24	21	26	26	24	21	25	26	25	21	24	25	24	21	22	23	23	20
85	kW	3.03	3.08	3.18	3.27	3.24	3.31	3.41	3.51	3.43	3.51	3.61	3.73	3.60	3.68	3.79	3.91	3.75	3.83	3.95	4.07	3.87	3.95	4.08	4.21
	Amps	6.1	6.4	6.7	7.1	7.0	7.3	7.6	8.1	8.0	8.3	8.7	9.2	8.8	9.2	9.6	10.2	9.7	10.1	10.6	11.2	10.6	11.0	11.5	12.1
	Hi PR	221	238	252	262	248	267	282	294	282	304	321	335	322	346	366	381	362	390	411	429	400	430	454	474
	Lo PR	108	115	125	134	114	121	133	141	119	126	138	147	125	133	145	154	131	139	152	162	135	144	157	167
	MBh	42.5	43.4	45.4	48.5	41.5	42.4	44.4	47.3	40.6	41.3	43.3	46.2	39.6	40.3	42.2	45.1	37.6	38.3	40.1	42.8	34.8	35.5	37.2	39.7
	S/T	0.92	0.88	0.80	0.65	0.95	0.92	0.83	0.67	0.97	0.94	0.85	0.69	1.00	0.97	0.88	0.71	1.00	1.00	0.91	0.74	1.00	1.00	0.92	0.74
	ΔT	26	26	25	21	27	26	25	22	27	26	25	22	27	27	25	22	25	26	25	21	24	24	23	20
	kW	2.96	3.02	3.10	3.20	3.17	3.23	3.33	3.43	3.35	3.42	3.53	3.64	3.52	3.59	3.70	3.82	3.66	3.74	3.85	3.97	3.78	3.86	3.98	4.11
	Amps	5.8	6.1	6.4	6.8	6.7	6.9	7.3	7.8	7.6	7.9	8.3	8.8	8.5	8.8	9.2	9.8	9.3	9.7	10.1	10.7	10.2	10.5	11.0	11.6
	Hi PR	215	231	244	254	241	259	274	286	274	295	311	325	312	336	355	370	351	378	399	416	388	417	441	460
Lo PR	105	111	122	130	111	118	129	137	115	122	134	142	121	129	140	150	127	135	147	157	131	139	152	162	

IDB: Entering Indoor Dry Bulb Temperature Shaded area reflects AHRI conditions kW=Total system power Amps = outdoor unit amps (comp.+fan)

EXPANDED COOLING DATA — ASZ140601A* / CA*F4860*6A*+TXV / MBE2000** -1

IDB	AIRFLOW	OUTDOOR AMBIENT TEMPERATURE												ENTERING INDOOR WET BULB TEMPERATURE											
		65°F				75°F				85°F				95°F				105°F				115°F			
		59	63	67	71	59	63	67	71	59	63	67	71	59	63	67	71	59	63	67	71	59	63	67	71
2081	MBh	55.4	57.4	62.9	-	54.1	56.1	61.4	-	52.8	54.7	59.9	-	51.5	53.4	58.5	-	48.9	50.7	55.6	-	45.3	47.0	51.5	-
	S/T	0.74	0.62	0.43	-	0.77	0.64	0.45	-	0.79	0.66	0.46	-	0.81	0.68	0.47	-	0.85	0.71	0.49	-	0.85	0.71	0.49	-
	ΔT	18	16	12	-	18	16	12	-	18	16	12	-	19	16	12	-	18	16	12	-	17	15	11	-
	kW	3.63	3.70	3.82	-	3.91	3.99	4.12	-	4.16	4.25	4.39	-	4.38	4.48	4.63	-	4.57	4.67	4.83	-	4.73	4.83	5.00	-
	Amps	7.6	7.9	8.4	-	8.7	9.1	9.6	-	10.0	10.4	10.9	-	11.1	11.5	12.1	-	12.2	12.7	13.3	-	13.3	13.8	14.5	-
	Hi PR	219	236	249	-	246	264	279	-	279	301	318	-	318	343	362	-	358	385	407	-	396	426	450	-
	Lo PR	103	110	120	-	109	116	126	-	113	120	131	-	119	126	138	-	125	132	145	-	129	137	150	-
	MBh	53.8	55.7	61.0	-	52.5	54.4	59.6	-	51.3	53.1	58.2	-	50.0	51.8	56.8	-	47.5	49.2	53.9	-	44.0	45.6	50.0	-
	S/T	0.71	0.59	0.41	-	0.73	0.61	0.42	-	0.75	0.63	0.44	-	0.78	0.65	0.45	-	0.81	0.67	0.47	-	0.81	0.68	0.47	-
	ΔT	19	16	12	-	19	17	13	-	19	17	13	-	19	17	13	-	19	16	13	-	18	15	12	-
70	kW	3.60	3.67	3.79	-	3.88	3.96	4.09	-	4.12	4.22	4.35	-	4.34	4.44	4.59	-	4.53	4.63	4.78	-	4.69	4.79	4.96	-
	Amps	7.4	7.8	8.2	-	8.6	8.9	9.4	-	9.8	10.2	10.8	-	11.0	11.4	12.0	-	12.1	12.5	13.1	-	13.2	13.6	14.3	-
	Hi PR	217	233	246	-	243	262	276	-	277	298	314	-	315	339	358	-	355	382	403	-	392	422	445	-
	Lo PR	102	108	118	-	108	115	125	-	112	119	130	-	118	125	137	-	123	131	143	-	128	136	148	-
	MBh	49.6	51.4	56.3	-	48.5	50.2	55.0	-	47.3	49.0	53.7	-	46.2	47.8	52.4	-	43.8	45.4	49.8	-	40.6	42.1	46.1	-
	S/T	0.68	0.57	0.40	-	0.71	0.59	0.41	-	0.73	0.61	0.42	-	0.75	0.63	0.43	-	0.78	0.65	0.45	-	0.78	0.65	0.45	-
	ΔT	19	17	13	-	19	17	13	-	19	17	13	-	20	17	13	-	19	17	13	-	18	16	12	-
	kW	3.51	3.58	3.70	-	3.78	3.86	3.99	-	4.02	4.11	4.24	-	4.23	4.33	4.47	-	4.41	4.51	4.66	-	4.57	4.67	4.83	-
	Amps	7.1	7.4	7.8	-	8.2	8.5	9.0	-	9.4	9.8	10.3	-	10.5	10.9	11.5	-	11.6	12.0	12.6	-	12.6	13.1	13.7	-
	Hi PR	210	226	239	-	236	254	268	-	268	289	305	-	306	329	347	-	344	370	391	-	380	409	432	-
Lo PR	99	105	115	-	105	111	121	-	109	116	126	-	114	121	133	-	120	127	139	-	124	132	144	-	

2081	MBh	56.3	58.0	62.7	67.3	55.0	56.6	61.3	65.8	53.7	55.3	59.8	64.2	52.4	53.9	58.4	62.6	49.8	51.2	55.5	59.5	46.1	47.5	51.4	55.1
	S/T	0.84	0.75	0.57	0.37	0.87	0.78	0.59	0.38	0.90	0.80	0.61	0.39	0.93	0.83	0.63	0.40	0.96	0.86	0.65	0.42	0.97	0.87	0.66	0.42
	ΔT	21	19	16	11	21	20	16	11	21	20	16	11	21	20	16	11	21	19	16	11	20	18	15	10
	kW	3.66	3.73	3.85	3.98	3.94	4.03	4.16	4.30	4.19	4.29	4.43	4.58	4.42	4.52	4.67	4.82	4.61	4.71	4.87	5.03	4.77	4.88	5.04	5.22
	Amps	7.7	8.0	8.5	9.1	8.8	9.2	9.7	10.3	10.1	10.5	11.1	11.8	11.3	11.7	12.3	13.0	12.4	12.9	13.5	14.3	13.5	14.0	14.7	15.5
	Hi PR	221	238	251	262	248	267	282	294	282	304	321	335	322	346	365	381	362	389	411	429	400	430	454	474
	Lo PR	104	111	121	129	110	117	128	136	114	122	133	141	120	128	139	148	126	134	146	156	130	138	151	161
	MBh	54.7	56.3	60.9	65.4	53.4	55.0	59.5	63.9	52.1	53.7	58.1	62.3	50.9	52.4	56.7	60.8	48.3	49.7	53.8	57.8	44.7	46.1	49.9	53.5
	S/T	0.80	0.72	0.54	0.35	0.83	0.75	0.56	0.36	0.86	0.77	0.58	0.37	0.88	0.79	0.60	0.38	0.92	0.82	0.62	0.40	0.92	0.83	0.63	0.40
	ΔT	22	20	16	11	22	20	17	12	22	20	17	12	22	21	17	12	22	20	17	11	21	19	16	11
75	kW	3.63	3.70	3.82	3.95	3.91	3.99	4.12	4.26	4.16	4.25	4.39	4.54	4.38	4.48	4.63	4.78	4.57	4.67	4.83	4.99	4.73	4.84	5.00	5.17
	Amps	7.6	7.9	8.4	8.9	8.7	9.1	9.6	10.2	10.0	10.4	10.9	11.6	11.1	11.5	12.1	12.8	12.2	12.7	13.3	14.1	13.3	13.8	14.5	15.3
	Hi PR	219	236	249	260	246	265	279	291	280	301	318	331	318	343	362	377	358	385	407	425	396	426	450	469
	Lo PR	103	110	120	127	109	116	126	135	113	120	131	140	119	126	138	147	125	132	145	154	129	137	150	159
	MBh	50.5	51.9	56.2	60.3	49.3	50.7	54.9	58.9	48.1	49.5	53.6	57.5	46.9	48.3	52.3	56.1	44.6	45.9	49.7	53.3	41.3	42.5	46.0	49.4
	S/T	0.78	0.69	0.53	0.34	0.80	0.72	0.54	0.35	0.82	0.74	0.56	0.36	0.85	0.76	0.58	0.37	0.88	0.79	0.60	0.38	0.89	0.80	0.60	0.39
	ΔT	22	20	17	12	23	21	17	12	23	21	17	12	23	21	17	12	22	21	17	12	21	19	16	11
	kW	3.54	3.61	3.73	3.85	3.81	3.90	4.02	4.15	4.06	4.14	4.28	4.42	4.27	4.36	4.51	4.66	4.45	4.55	4.70	4.86	4.61	4.71	4.87	5.04
	Amps	7.2	7.5	8.0	8.5	8.3	8.6	9.1	9.7	9.5	9.9	10.5	11.1	10.6	11.0	11.6	12.3	11.7	12.2	12.8	13.5	12.8	13.3	13.9	14.7
	Hi PR	212	229	241	252	238	257	271	283	271	292	308	321	309	332	351	366	347	374	395	412	384	413	436	455
Lo PR	100	106	116	124	106	112	123	131	110	117	127	136	115	123	134	143	121	129	140	149	125	133	145	155	

IDB: Entering Indoor Dry Bulb Temperature Shaded area reflects ACCA (TVA) conditions kW=Total system power Amps = outdoor unit amps (comp.+fan)

EXPANDED COOLING DATA — ASZ140601A* / CA*F4860*6A*+TXV / MBE2000** -1 (CONT.)

IDB	OUTDOOR AMBIENT TEMPERATURE												ENTERING INDOOR WET BULB TEMPERATURE												
	65°F				75°F				85°F				95°F				105°F				115°F				
	59	63	67	71	59	63	67	71	59	63	67	71	59	63	67	71	59	63	67	71	59	63	67	71	
2081	MBh	57.3	58.6	62.6	66.9	56.0	57.2	61.1	65.3	54.6	55.8	59.6	63.8	53.3	54.5	58.2	62.2	50.6	51.7	55.3	59.1	46.9	47.9	51.2	54.7
	S/T	0.93	0.87	0.71	0.53	0.96	0.90	0.73	0.55	1.00	0.92	0.75	0.56	1.00	0.95	0.78	0.58	1.00	1.00	0.80	0.60	1.00	1.00	0.81	0.61
	ΔT	23	22	20	16	24	23	20	16	24	23	20	16	24	23	20	16	22	21	20	16	21	21	18	15
	kW	3.69	3.76	3.89	4.01	3.97	4.06	4.19	4.33	4.23	4.32	4.47	4.62	4.45	4.55	4.71	4.87	4.64	4.75	4.91	5.08	4.81	4.92	5.09	5.26
	Amps	7.8	8.2	8.6	9.2	9.0	9.3	9.9	10.5	10.3	10.7	11.3	11.9	11.4	11.9	12.5	13.2	12.6	13.0	13.7	14.5	13.7	14.2	14.9	15.7
	Hi PR	223	240	254	265	251	270	285	297	285	307	324	338	325	350	369	385	365	393	415	433	404	434	459	479
	Lo PR	105	112	122	130	111	118	129	137	115	123	134	143	121	129	141	150	127	135	148	157	131	140	153	163
	MBh	55.6	56.9	60.7	64.9	54.3	55.5	59.3	63.4	53.0	54.2	57.9	61.9	51.8	52.9	56.5	60.4	49.2	50.2	53.7	57.4	45.5	46.5	49.7	53.2
	S/T	0.88	0.83	0.67	0.50	0.91	0.86	0.70	0.52	0.94	0.88	0.72	0.54	0.97	0.91	0.74	0.55	1.00	0.94	0.77	0.57	1.00	0.95	0.77	0.58
	ΔT	24	23	20	16	25	24	21	16	25	24	21	16	25	24	21	17	24	24	20	16	23	22	19	15
80	kW	3.66	3.73	3.85	3.98	3.94	4.03	4.16	4.30	4.19	4.29	4.43	4.58	4.42	4.52	4.67	4.82	4.61	4.71	4.87	5.03	4.77	4.88	5.04	5.22
	Amps	7.7	8.0	8.5	9.1	8.8	9.2	9.7	10.3	10.1	10.5	11.1	11.8	11.3	11.7	12.3	13.0	12.4	12.9	13.5	14.3	13.5	14.0	14.7	15.5
	Hi PR	221	238	251	262	248	267	282	294	282	304	321	335	322	346	365	381	362	389	411	429	400	430	454	474
	Lo PR	104	111	121	129	110	117	128	136	114	122	133	141	120	128	139	148	126	134	146	156	130	138	151	161
	MBh	51.4	52.5	56.1	59.9	50.2	51.3	54.8	58.5	49.0	50.0	53.5	57.1	47.8	48.8	52.1	55.7	45.4	46.4	49.5	53.0	42.0	43.0	45.9	49.1
	S/T	0.85	0.80	0.65	0.49	0.88	0.83	0.67	0.50	0.90	0.85	0.69	0.52	0.93	0.88	0.71	0.53	0.97	0.91	0.74	0.55	0.98	0.92	0.75	0.56
	ΔT	25	24	21	17	25	24	21	17	25	24	21	17	25	24	21	17	25	24	21	17	23	22	19	16
	kW	3.57	3.64	3.76	3.88	3.84	3.93	4.06	4.19	4.09	4.18	4.32	4.46	4.31	4.40	4.55	4.70	4.49	4.59	4.74	4.90	4.65	4.75	4.91	5.08
	Amps	7.3	7.6	8.1	8.6	8.4	8.8	9.3	9.9	9.7	10.1	10.6	11.3	10.8	11.2	11.8	12.5	11.9	12.3	13.0	13.7	13.0	13.4	14.1	14.9
	Hi PR	215	231	244	254	241	259	274	285	274	295	311	325	312	336	354	370	351	378	399	416	388	417	441	460
Lo PR	101	107	117	125	107	113	124	132	111	118	129	137	116	124	135	144	122	130	142	151	126	134	147	156	

2081	MBh	58.3	59.4	62.2	66.4	56.9	58.1	60.8	64.9	55.6	56.7	59.4	63.3	54.2	55.3	57.9	61.8	51.5	52.5	55.0	58.7	47.7	48.7	51.0	54.4
	S/T	0.97	0.94	0.85	0.69	1.00	0.97	0.88	0.71	1.00	1.00	0.90	0.73	1.00	1.00	0.93	0.75	1.00	1.00	0.96	0.78	1.00	1.00	0.97	0.79
	ΔT	25	25	23	20	25	25	24	20	25	25	24	20	24	24	24	21	23	23	23	20	21	21	22	19
	kW	3.72	3.80	3.92	4.05	4.01	4.09	4.23	4.37	4.26	4.36	4.50	4.66	4.49	4.59	4.75	4.91	4.68	4.79	4.95	5.12	4.85	4.96	5.13	5.31
	Amps	8.0	8.3	8.8	9.3	9.1	9.5	10.0	10.6	10.4	10.9	11.4	12.1	11.6	12.0	12.7	13.4	12.8	13.2	13.9	14.7	13.9	14.4	15.1	15.9
	Hi PR	226	243	256	268	253	273	288	300	288	310	327	341	328	353	373	389	369	397	419	437	408	439	463	483
	Lo PR	106	113	123	131	112	119	130	139	117	124	135	144	122	130	142	151	128	137	149	159	133	141	154	164
	MBh	56.6	57.7	60.4	64.5	55.3	56.4	59.0	63.0	54.0	55.0	57.6	61.5	52.7	53.7	56.2	60.0	50.0	51.0	53.4	57.0	46.3	47.2	49.5	52.8
	S/T	0.93	0.89	0.81	0.65	0.96	0.93	0.84	0.68	0.98	0.95	0.86	0.69	1.00	0.98	0.88	0.72	1.00	1.00	0.92	0.74	1.00	1.00	0.93	0.75
	ΔT	26	26	24	21	26	26	25	21	26	26	25	21	26	26	25	21	25	25	24	21	23	23	23	20
85	kW	3.69	3.76	3.89	4.01	3.97	4.06	4.19	4.33	4.23	4.32	4.47	4.62	4.45	4.55	4.71	4.87	4.64	4.75	4.91	5.08	4.81	4.92	5.09	5.26
	Amps	7.8	8.2	8.6	9.2	9.0	9.3	9.9	10.5	10.3	10.7	11.3	11.9	11.4	11.9	12.5	13.2	12.6	13.0	13.7	14.5	13.7	14.2	14.9	15.7
	Hi PR	223	240	254	265	251	270	285	297	285	307	324	338	325	350	369	385	365	393	415	433	404	434	459	479
	Lo PR	105	112	122	130	111	118	129	137	115	123	134	143	121	129	141	150	127	135	148	157	131	140	153	163
	MBh	52.2	53.3	55.8	59.5	51.0	52.0	54.5	58.1	49.8	50.8	53.2	56.7	48.6	49.5	51.9	55.4	46.2	47.1	49.3	52.6	42.8	43.6	45.7	48.7
	S/T	0.89	0.86	0.78	0.63	0.92	0.89	0.81	0.65	0.95	0.92	0.83	0.67	0.98	0.94	0.85	0.69	1.00	0.98	0.88	0.72	1.00	0.99	0.89	0.72
	ΔT	26	26	25	21	27	26	25	22	27	26	25	22	27	27	25	22	26	26	25	21	24	24	23	20
	kW	3.60	3.67	3.79	3.91	3.88	3.96	4.09	4.22	4.12	4.21	4.35	4.50	4.34	4.44	4.59	4.74	4.53	4.63	4.78	4.95	4.69	4.79	4.95	5.12
	Amps	7.4	7.8	8.2	8.8	8.6	8.9	9.4	10.0	9.8	10.2	10.8	11.4	10.9	11.4	12.0	12.6	12.1	12.5	13.1	13.9	13.1	13.6	14.3	15.1
	Hi PR	217	233	246	257	243	262	276	288	277	298	314	328	315	339	358	373	354	381	403	420	392	421	445	464
Lo PR	102	108	118	126	108	115	125	133	112	119	130	138	118	125	137	145	123	131	143	152	127	136	148	158	

IDB: Entering Indoor Dry Bulb Temperature kW=Total system power Shaded area reflects AHRI conditions Amps = outdoor unit amps (comp.+fan)

EXPANDED HEATING DATA

ASZ140181A* / CA*F3131*6A* +TXV / MBR800**-1

	OUTDOOR AMBIENT TEMPERATURE																	
	65	60	55	50	47	45	40	35	30	25	20	17	15	10	5	0	-5	-10
MBh	22.6	21.4	20.2	18.8	18.0	17.4	16.2	14.9	12.8	11.8	10.9	10.3	9.9	8.9	7.9	6.9	5.9	4.8
DT	34.9	33.1	31.1	29.1	27.8	26.9	25.0	23.1	19.7	18.2	16.8	15.8	15.3	13.7	12.1	10.6	9.0	7.4
kW	1.56	1.53	1.50	1.47	1.45	1.44	1.41	1.38	1.39	1.36	1.32	1.31	1.29	1.26	1.23	1.20	1.17	1.14
Amps	7.0	6.5	6.1	5.7	5.5	5.4	5.1	4.9	4.7	4.5	4.2	4.1	4.1	3.9	3.6	3.4	3.2	2.9
COP	4.23	4.09	3.93	3.75	3.62	3.54	3.36	3.16	2.70	2.55	2.40	2.30	2.24	2.06	1.87	1.67	1.47	1.23
EER	14.5	14.0	13.4	12.8	12.4	12.1	11.5	10.8	9.2	8.7	8.2	7.9	7.6	7.0	6.4	5.7	5.0	4.2
Hi PR	385	369	355	339	331	325	312	300	287	274	263	257	252	243	234	224	216	208
Lo PR	149	138	129	118	112	108	99	88	80	71	62	58	56	47	41	34	30	24

ASZ140241A* / CA*F3636*6A* +TXV / MBR800**-1

	OUTDOOR AMBIENT TEMPERATURE																	
	65	60	55	50	47	45	40	35	30	25	20	17	15	10	5	0	-5	-10
MBh	30.2	28.6	26.9	25.1	24.0	23.3	21.6	19.9	17.9	16.6	15.2	14.4	13.9	12.4	11.0	9.6	8.2	6.7
DT	32.9	31.1	29.3	27.4	26.1	25.3	23.5	21.7	19.5	18.0	16.6	15.7	15.1	13.5	12.0	10.5	8.9	7.3
kW	2.08	2.04	2.00	1.96	1.94	1.92	1.89	1.85	1.87	1.82	1.78	1.76	1.74	1.70	1.66	1.62	1.58	1.54
Amps	8.1	7.9	7.7	7.5	7.4	7.3	7.2	7.1	7.0	6.9	6.8	6.7	6.7	6.6	6.5	6.3	6.2	6.1
COP	4.24	4.09	3.93	3.74	3.62	3.54	3.35	3.16	2.81	2.65	2.50	2.39	2.33	2.14	1.94	1.73	1.52	1.28
EER	14.5	14.0	13.4	12.8	12.4	12.1	11.4	10.8	9.6	9.1	8.5	8.2	7.9	7.3	6.6	5.9	5.2	4.4
Hi PR	373	358	344	329	321	315	303	290	278	266	255	249	245	235	226	217	209	202
Lo PR	143	133	124	114	108	104	95	85	77	68	60	56	54	46	39	33	29	23

ASZ140301A* / CA*F3642*6A* +TXV / MBR1600**-1

	OUTDOOR AMBIENT TEMPERATURE																	
	65	60	55	50	47	45	40	35	30	25	20	17	15	10	5	0	-5	-10
MBh	36.5	34.5	32.5	30.4	29.0	28.1	26.1	24.1	22.6	20.9	19.2	18.2	17.5	15.7	13.9	12.1	10.3	8.5
DT	32.1	30.4	28.6	26.8	25.6	24.8	23.0	21.2	19.9	18.4	17.0	16.0	15.4	13.8	12.3	10.7	9.1	7.5
kW	2.40	2.36	2.32	2.27	2.25	2.23	2.19	2.14	2.20	2.15	2.11	2.08	2.06	2.01	1.97	1.92	1.87	1.83
Amps	11.8	10.6	9.6	8.7	8.2	8.0	7.2	6.6	6.1	5.6	5.1	4.9	4.8	4.3	3.6	3.1	2.5	1.8
COP	4.44	4.28	4.10	3.91	3.78	3.69	3.50	3.29	3.01	2.84	2.67	2.55	2.48	2.28	2.07	1.85	1.62	1.36
EER	15.2	14.6	14.0	13.4	12.9	12.6	11.9	11.2	10.3	9.7	9.1	8.7	8.5	7.8	7.1	6.3	5.5	4.6
Hi PR	360	346	332	318	310	304	292	281	269	257	247	241	236	227	219	210	202	195
Lo PR	137	127	119	110	104	100	92	82	74	66	58	54	52	44	38	32	28	22

ASZ140361A* / CA*F4860*6A* +TXV / MBR1600**-1

	OUTDOOR AMBIENT TEMPERATURE																	
	65	60	55	50	47	45	40	35	30	25	20	17	15	10	5	0	-5	-10
MBh	43.5	41.2	38.8	36.2	34.6	33.5	31.1	28.7	28.8	26.6	24.5	23.1	22.3	20.0	17.7	15.5	13.2	10.8
DT	38.4	36.3	34.2	31.9	30.5	29.6	27.5	25.3	25.4	23.5	21.6	20.4	19.6	17.6	15.6	13.6	11.6	9.5
kW	3.05	2.99	2.94	2.88	2.84	2.82	2.76	2.71	2.78	2.72	2.66	2.62	2.60	2.53	2.47	2.41	2.35	2.29
Amps	13.8	12.8	12.0	11.3	10.9	10.7	10.1	9.6	9.2	8.9	8.4	8.3	8.2	7.8	7.3	6.9	6.4	5.8
COP	4.17	4.02	3.86	3.68	3.56	3.48	3.30	3.11	3.03	2.86	2.70	2.58	2.51	2.31	2.10	1.87	1.64	1.38
EER	14.3	13.8	13.2	12.6	12.2	11.9	11.3	10.6	10.4	9.8	9.2	8.8	8.6	7.9	7.2	6.4	5.6	4.7
Hi PR	384	368	353	338	330	324	311	299	286	273	262	256	251	242	233	223	215	208
Lo PR	144	134	125	115	109	105	96	86	77	69	61	56	54	46	40	33	29	23

High pressure is measured at the suction service valve (the larger valve).
 Low pressure is measured at the gauge port connection.
 Calculations are based on nominal CFM and 70°F indoor dry bulb.

Amps = Outdoor unit amps (comp.+fan)
 kW = Total system power

EXPANDED HEATING DATA (CONT.)

ASZ140361B*/AR*F374316B*

	OUTDOOR AMBIENT TEMPERATURE																	
	65	60	55	50	47	45	40	35	30	25	20	17	15	10	5	0	-5	-10
MBh	41.5	39.3	37.0	34.6	33.0	32.0	29.7	27.4	24.9	23.0	21.2	20.0	19.3	17.3	15.3	13.4	11.4	9.3
DT	30.7	29.1	27.4	25.6	24.4	23.7	22.0	20.3	18.5	17.0	15.7	14.8	14.3	12.8	11.3	9.9	8.4	6.9
kW	2.95	2.90	2.85	2.79	2.76	2.74	2.69	2.64	2.93	2.86	2.80	2.76	2.74	2.68	2.61	2.55	2.49	2.43
Amps	11.8	11.0	10.3	9.8	9.4	9.3	8.8	8.4	8.0	7.7	7.4	7.2	7.1	6.8	6.4	6.1	5.7	5.2
COP	4.11	3.96	3.80	3.62	3.49	3.41	3.23	3.04	2.49	2.35	2.21	2.12	2.06	1.89	1.71	1.53	1.34	1.13
EER	14.0	13.5	13.0	12.4	11.9	11.7	11.0	10.4	8.5	8.0	7.6	7.2	7.0	6.5	5.9	5.2	4.6	3.8
Hi PR	346	332	319	305	298	292	281	270	258	247	237	231	227	218	210	201	194	187
Lo PR	140	130	121	111	105	101	93	83	75	67	59	55	53	44	38	32	28	22

ASZ140421A* / CA*F4860*6A*+TXV / MBR2000**-1

	OUTDOOR AMBIENT TEMPERATURE																	
	65	60	55	50	47	45	40	35	30	25	20	17	15	10	5	0	-5	-10
MBh	51.5	48.8	45.9	42.9	41.0	39.7	36.9	34.0	34.3	31.6	29.1	27.5	26.5	23.8	21.1	18.4	15.7	12.8
DT	34.1	32.3	30.4	28.4	27.1	26.3	24.4	22.5	22.7	20.9	19.3	18.2	17.5	15.7	13.9	12.1	10.4	8.5
kW	3.40	3.33	3.27	3.21	3.17	3.14	3.08	3.02	3.07	3.00	2.94	2.90	2.87	2.81	2.74	2.68	2.61	2.54
Amps	15.2	14.1	13.2	12.4	12.0	11.8	11.1	10.6	10.1	9.7	9.2	9.0	8.9	8.5	7.9	7.5	6.9	6.3
COP	4.44	4.28	4.11	3.92	3.79	3.70	3.50	3.30	3.26	3.08	2.90	2.78	2.70	2.48	2.25	2.01	1.76	1.48
EER	15.2	14.6	14.0	13.4	12.9	12.6	12.0	11.3	11.2	10.5	9.9	9.5	9.2	8.5	7.7	6.9	6.0	5.1
Hi PR	370	354	341	326	318	312	300	288	276	263	253	247	242	233	224	215	207	200
Lo PR	142	132	123	113	107	103	95	84	76	68	60	56	53	45	39	33	29	23

ASZ140481A* / CA*F4860*6A*+TXV / MBR2000**-1

	OUTDOOR AMBIENT TEMPERATURE																	
	65	60	55	50	47	45	40	35	30	25	20	17	15	10	5	0	-5	-10
MBh	57.8	54.7	51.5	48.2	46.0	44.6	41.4	38.2	36.6	33.8	31.1	29.4	28.3	25.4	22.5	19.6	16.8	13.7
DT	34.5	32.7	30.8	28.8	27.5	26.6	24.7	22.8	21.9	20.2	18.6	17.6	16.9	15.2	13.4	11.7	10.0	8.2
kW	3.98	3.90	3.83	3.75	3.71	3.68	3.60	3.53	3.65	3.57	3.49	3.44	3.41	3.32	3.24	3.16	3.08	3.00
Amps	19.4	17.6	16.1	14.8	14.1	13.7	12.7	11.7	11.0	10.3	9.5	9.2	9.0	8.3	7.4	6.6	5.7	4.6
COP	4.25	4.10	3.94	3.76	3.63	3.55	3.36	3.17	2.94	2.77	2.61	2.50	2.43	2.24	2.03	1.82	1.59	1.34
EER	14.5	14.0	13.5	12.8	12.4	12.1	11.5	10.8	10.0	9.5	8.9	8.5	8.3	7.6	6.9	6.2	5.4	4.6
Hi PR	408	391	376	359	351	344	331	318	304	291	279	272	267	257	247	237	229	221
Lo PR	136	126	118	109	103	99	91	81	73	65	57	53	51	43	37	32	28	22

ASZ140601A* / CA*F4860*6A*+TXV / MBE2000**-1

	OUTDOOR AMBIENT TEMPERATURE																	
	65	60	55	50	47	45	40	35	30	25	20	17	15	10	5	0	-5	-10
MBh	71.6	67.8	63.8	59.7	57.0	55.2	51.3	47.3	47.9	44.2	40.7	38.4	37.0	33.2	29.4	25.7	21.9	17.9
DT	35.9	33.9	32.0	29.9	28.5	27.6	25.7	23.7	24.0	22.1	20.4	19.2	18.5	16.6	14.7	12.8	11.0	9.0
kW	4.83	4.74	4.64	4.54	4.48	4.44	4.35	4.25	4.42	4.32	4.21	4.15	4.11	4.00	3.90	3.80	3.69	3.59
Amps	24.7	22.3	20.4	18.8	17.9	17.4	16.0	14.8	13.9	12.9	12.0	11.5	11.3	10.4	9.2	8.2	7.1	5.7
COP	4.34	4.19	4.03	3.85	3.72	3.64	3.45	3.26	3.17	2.99	2.83	2.71	2.63	2.43	2.21	1.98	1.74	1.46
EER	14.8	14.3	13.8	13.1	12.7	12.4	11.8	11.1	10.8	10.2	9.7	9.3	9.0	8.3	7.5	6.8	5.9	5.0
Hi PR	404	387	372	356	347	341	327	314	301	288	276	269	265	255	245	235	226	218
Lo PR	136	126	119	109	103	99	91	81	73	65	57	53	51	43	37	32	28	22

High pressure is measured at the suction service valve (the larger valve).

Low pressure is measured at the gauge port connection.

Calculations are based on nominal CFM and 70°F indoor dry bulb.

Amps = Outdoor unit amps (comp.+fan)

kW = Total system power

AHRI RATINGS

OUTDOOR UNIT	INDOOR UNITS		COOLING CAPACITY				TVA RATINGS ³		HEATING CAPACITY			AHRI #
	COIL & BLOWER UNITS	FURNACE	TOTAL	SENS.	SEER ¹	EER ²	TOTAL	SENS.	HIGH	HSPF ⁴	LOW	
ASZ14 0181A*	AEPF183016C*+TXV		19,000	13,900	15.0	13.0	17,600	13,700	18,000	8.5	10,400	1492735
	AR*F193116B*+TXV		19,000	13,900	14.5	12.5	17,600	13,700	18,000	8.5	10,000	1492736
	AR*F193116C*+TXV		19,000	13,900	14.5	12.5	17,600	13,700	18,000	8.2	10,000	4261907
	ASPF183016B*+TXV		19,000	13,900	15.0	13.0	17,600	13,700	18,000	8.5	10,400	1492737
	ASPF183016C*+TXV		19,000	13,900	15.0	13.0	17,600	13,700	18,000	8.5	10,400	4248562
	ASPF183016D*+TXV		19,000	13,900	15.0	13.0	17,600	13,700	18,000	8.5	10,400	4149368
	ASPF183016E*+TXV		19,000	13,900	15.0	13.0	17,600	13,700	18,000	8.5	10,400	4248563
	AVPTC183014A*		19,000	13,900	15.0	13.0	17,600	13,700	18,000	8.5	10,400	4431360
	CA*F3131*6B*+EEP+TXV		19,000	13,900	14.0	12.0	17,600	13,700	18,000	8.3	10,600	1346967
	CA*F3131*6B*+TXV	G*VC950453BXA*	18,000	13,100	15.0	12.5	16,700	13,000	18,000	8.1	10,200	3597413
	CA*F3131*6B*+TXV	A*VC950453BXA*	18,000	13,100	15.0	12.5	16,700	13,000	18,000	8.1	10,200	3597173
	CA*F3131*6B*+TXV	G*V950453B**	18,000	13,100	15.0	12.5	16,700	13,000	18,000	8.1	10,200	3204585
	CA*F3131*6B*+TXV	MBR0800**-1	18,000	13,100	14.0	12.0	16,700	13,000	18,000	8.5	10,800	1347336
	CA*F3131*6B*+TXV	MBE1200**-1	18,000	13,100	15.0	12.5	16,700	13,000	18,000	8.1	10,200	1347335
	CA*F3131*6B*+TXV	A*V90453B**	18,000	13,100	15.0	12.5	16,700	13,000	18,000	8.1	10,200	1346969
	CA*F3131*6B*+TXV	A*V80704B**	18,000	13,100	15.0	12.5	16,700	13,000	18,000	8.1	10,200	1346968
	CA*F3131*6C*+EEP+TXV		19,000	13,900	14.0	12.0	17,600	13,700	18,000	8.3	10,600	1386257
	CA*F3131*6C*+TXV	MBVC1200**-1A*	18,000	13,100	15.0	12.5	16,700	13,000	18,000	8.1	10,200	3674520
	CA*F3131*6C*+TXV	G*VC950453BXA*	18,000	13,100	15.0	12.5	16,700	13,000	18,000	8.1	10,200	3597414
	CA*F3131*6C*+TXV	A*VC950453BXA*	18,000	13,100	15.0	12.5	16,700	13,000	18,000	8.1	10,200	3597174
	CA*F3131*6C*+TXV	G*V950453B**	18,000	13,100	15.0	12.5	16,700	13,000	18,000	8.1	10,200	3204586
	CA*F3131*6C*+TXV	MBR0800**-1A*	18,000	13,100	14.0	12.0	16,700	13,000	18,000	8.5	10,800	1401074
	CA*F3131*6C*+TXV	A*V90453B**	18,000	13,100	15.0	12.5	16,700	13,000	18,000	8.1	10,200	1386261
	CA*F3131*6C*+TXV	A*V80704B**	18,000	13,100	15.0	12.5	16,700	13,000	18,000	8.1	10,200	1386260
	CA*F3131*6C*+TXV	MBE1200**-1	18,000	13,100	15.0	12.5	16,700	13,000	18,000	8.1	10,200	1386259
	CA*F3131*6D*+EEP+TXV		18,400	13,400	14.0	12.0	17,000	13,300	18,000	8.0	10,400	4385615
	CA*F3131*6D*+TXV	MBVC1200**-1A*	18,000	13,100	15.0	12.5	16,700	13,000	17,900	8.1	10,000	4385618
	CA*F3131*6D*+TXV	G*VC950453BXA*	18,000	13,100	15.0	12.5	16,700	13,000	18,000	8.1	10,100	4385617
	CA*F3131*6D*+TXV	A*VC950453BXA*	18,000	13,100	15.0	12.5	16,700	13,000	18,000	8.1	10,100	4385616
	CHPF2430B6B*+EEP+TXV		19,000	13,900	14.0	12.0	17,600	13,700	18,000	8.5	10,400	1330179
	CHPF2430B6B*+TXV	A*VC950453BXA*	18,000	13,100	15.0	12.5	16,700	13,000	18,000	8.1	10,200	3597172
	CHPF2430B6B*+TXV	MBE1200**-1A*	18,400	13,400	14.0	12.0	17,000	13,300	18,000	8.5	10,800	1347527
	CHPF2430B6B*+TXV	MBR0800**-1A*	18,000	13,100	14.0	12.0	16,700	13,000	18,000	8.5	10,800	1330208
	CHPF2430B6B*+TXV	A*V90453B**	18,000	13,100	15.0	12.5	16,700	13,000	18,000	8.1	10,200	1330181
	CHPF2430B6B*+TXV	A*V80704B**	18,000	13,100	15.0	12.5	16,700	13,000	18,000	8.1	10,200	1330180
	CHPF2430B6C*+EEP+TXV		19,000	13,900	14.0	12.0	17,600	13,700	18,000	8.5	10,400	3299327
	CHPF2430B6C*+TXV	MBVC1200**-1A*	18,400	13,400	14.0	12.0	17,000	13,300	18,000	8.5	10,800	3674546
	CHPF2430B6C*+TXV	A*VC950453BXA*	18,000	13,100	15.0	12.5	16,700	13,000	18,000	8.1	10,200	3597175
	CHPF2430B6C*+TXV	A*V90453B**	18,000	13,100	15.0	12.5	16,700	13,000	18,000	8.1	10,200	3299331
	CHPF2430B6C*+TXV	A*V80704B**	18,000	13,100	15.0	12.5	16,700	13,000	18,000	8.1	10,200	3299330
	CHPF2430B6C*+TXV	MBR0800**-1A*	18,000	13,100	14.0	12.0	16,700	13,000	18,000	8.5	10,800	3299329
	CHPF2430B6C*+TXV	MBE1200**-1B*	18,400	13,400	14.0	12.0	17,000	13,300	18,000	8.5	10,800	3299328
	CHPF3636B6B*+TXV	MBE1200**-1A*	19,000	13,900	15.0	13.0	17,600	13,700	18,000	8.5	10,400	1347525
	CHPF3636B6C*+TXV	MBVC1200**-1A*	19,000	13,900	15.0	13.0	17,600	13,700	18,000	8.5	10,400	3674548
	CHPF3636B6C*+TXV	MBE1200**-1B*	19,000	13,900	15.0	13.0	17,600	13,700	18,000	8.5	10,400	3299332
	CSCF3036N6B*+TXV	A*VC950453BXA*	18,000	13,100	15.0	12.5	16,700	13,000	18,000	8.1	10,200	3597171
	CSCF3036N6B*+TXV	A*V90453B**	18,000	13,100	15.0	12.5	16,700	13,000	18,000	8.1	10,200	1296571
CSCF3036N6B*+TXV	A*V80704B**	18,000	13,100	15.0	12.5	16,700	13,000	18,000	8.1	10,200	1296570	

See Notes on Page 33.

AHRI RATINGS (CONT.)

OUTDOOR UNIT	INDOOR UNITS		COOLING CAPACITY				TVA RATINGS ³		HEATING CAPACITY			AHRI #
	COIL & BLOWER UNITS	FURNACE	TOTAL	SENS.	SEER ¹	EER ²	TOTAL	SENS.	HIGH	HSPF ⁴	LOW	
ASZ14 0241A*	AEPF303616C*+TXV		24,000	18,000	15.0	13.0	22,200	17,800	22,000	8.5	12,000	1444012
	AEPF313716A*+TXV		24,000	18,000	15.0	13.0	22,200	17,800	22,000	8.5	12,000	3323251
	AR*F193116B*+TXV		24,000	18,000	14.0	12.0	22,200	17,800	24,000	8.5	14,000	1492738
	ASPF183016B*+TXV		23,600	17,700	15.0	12.5	21,800	17,400	22,000	8.6	12,000	3606563
	ASPF183016C*+TXV		23,600	17,700	15.0	12.5	21,800	17,400	22,000	8.6	12,000	4248564
	ASPF183016D*+TXV		23,600	17,700	15.0	12.5	21,800	17,400	22,000	8.6	12,000	4149369
	ASPF183016E*+TXV		23,600	17,700	15.0	12.5	21,800	17,400	22,000	8.6	12,000	4248565
	ASPF303616B*+TXV		24,000	18,000	15.0	13.0	22,200	17,800	22,000	8.5	12,000	1444021
	ASPF313716A*+TXV		24,000	18,000	15.0	13.0	22,200	17,800	22,000	8.5	12,000	3323255
	ASPF313716C*+TXV		24,000	18,000	15.0	13.0	22,200	17,800	22,000	8.5	12,000	4355493
	ASPF313716D*+TXV		24,000	18,000	15.0	13.0	22,200	17,800	22,000	8.5	12,000	4149370
	ASPF313716E*+TXV		24,000	18,000	15.0	13.0	22,200	17,800	22,000	8.5	12,000	4355499
	AVPTC313714A*		24,000	18,000	15.0	13.0	22,200	17,800	22,000	8.5	12,000	4431361
	AWUF31XX16A*		24,000	18,000	14.5	12.5	22,200	17,800	23,000	8.5	13,400	4392998
	AWUF31XX16A*+TXV		24,000	18,000	15.0	12.7	22,200	17,800	23,000	8.5	13,400	4392999
	AWUF32XX16A*		24,000	18,000	14.5	12.5	22,200	17,800	23,000	8.5	13,400	4393000
	AWUF32XX16A*+TXV		24,000	18,000	15.0	12.7	22,200	17,800	23,000	8.5	13,400	4393001
	CA*F3636*6B*+EEP+TXV		24,000	18,000	14.0	12.5	22,200	17,800	24,000	8.5	14,000	1346970
	CA*F3636*6B*+TXV	G*VC950704CXA*	23,600	17,700	15.0	12.5	21,800	17,400	23,000	8.3	14,500	3597416
	CA*F3636*6B*+TXV	G*VC950453BXA*	23,600	17,700	14.5	12.2	21,800	17,400	23,600	8.3	14,500	3597415
	CA*F3636*6B*+TXV	A*VC950704CXA*	23,600	17,700	15.0	12.5	21,800	17,400	23,000	8.3	14,500	3597218
	CA*F3636*6B*+TXV	A*VC950453BXA*	23,600	17,700	14.5	12.2	21,800	17,400	23,600	8.3	14,500	3597187
	CA*F3636*6B*+TXV	A*VC90704CXA*	23,600	17,700	15.0	12.5	21,800	17,400	23,000	8.3	14,500	3597047
	CA*F3636*6B*+TXV	G*V950453B**	23,600	17,700	14.5	12.2	21,800	17,400	23,600	8.3	14,500	3204587
	CA*F3636*6B*+TXV	G*V950704C**	23,600	17,700	15.0	12.5	21,800	17,400	23,000	8.3	14,500	3043663
	CA*F3636*6B*+TXV	A*V90704C**	23,600	17,700	15.0	12.5	21,800	17,400	23,000	8.3	14,500	1451749
	CA*F3636*6B*+TXV	A*V90453B**	23,600	17,700	14.5	12.2	21,800	17,400	23,600	8.3	14,500	1346975
	CA*F3636*6B*+TXV	A*V80704B**	23,600	17,700	14.5	12.2	21,800	17,400	23,000	8.3	14,500	1346974
	CA*F3636*6B*+TXV	MBR0800**-1	24,000	18,000	14.0	12.0	22,200	17,800	24,000	8.3	14,500	1346973
	CA*F3636*6B*+TXV	MBE1600**-1	24,000	18,000	15.0	13.0	22,200	17,800	22,000	8.5	12,000	1346972
	CA*F3636*6B*+TXV	MBE1200**-1	24,000	18,000	15.0	12.5	22,200	17,800	24,000	8.5	14,500	1346971
	CA*F3636*6C*+EEP+TXV		24,000	18,000	14.0	12.5	22,200	17,800	24,000	8.5	14,000	3801253
	CA*F3636*6C*+TXV	G*VC950714CXA*	23,600	17,700	15.0	12.5	21,800	17,400	23,000	8.2	14,500	4185031
	CA*F3636*6C*+TXV	A*VC950714CXA*	23,600	17,700	15.0	12.5	21,800	17,400	23,000	8.2	14,500	4185030
	CA*F3636*6C*+TXV	MBVC1200**-1A*	24,000	18,000	15.0	12.5	22,200	17,800	24,000	8.5	14,500	3870262
	CA*F3636*6C*+TXV	MBVC1600**-1A*	24,000	18,000	15.0	13.0	22,200	17,800	22,000	8.5	12,000	3870261
	CA*F3636*6C*+TXV	G*VC950704CXA*	23,600	17,700	15.0	12.5	21,800	17,400	23,000	8.3	14,500	3801363
	CA*F3636*6C*+TXV	G*VC950453BXA*	23,600	17,700	14.5	12.2	21,800	17,400	23,600	8.3	14,500	3801362
	CA*F3636*6C*+TXV	A*VC950704CXA*	23,600	17,700	15.0	12.5	21,800	17,400	23,000	8.3	14,500	3801361
	CA*F3636*6C*+TXV	A*VC950453BXA*	23,600	17,700	14.5	12.2	21,800	17,400	23,600	8.3	14,500	3801360
	CA*F3636*6C*+TXV	A*VC90704CXA*	23,600	17,700	15.0	12.5	21,800	17,400	23,000	8.3	14,500	3801359
	CA*F3636*6C*+TXV	G*V950704C**	23,600	17,700	15.0	12.5	21,800	17,400	23,000	8.3	14,500	3801260
	CA*F3636*6C*+TXV	G*V950453B**	23,600	17,700	14.5	12.2	21,800	17,400	23,600	8.3	14,500	3801259
	CA*F3636*6C*+TXV	A*V90704C**	23,600	17,700	15.0	12.5	21,800	17,400	23,000	8.3	14,500	3801258
	CA*F3636*6C*+TXV	A*V90453B**	23,600	17,700	14.5	12.2	21,800	17,400	23,600	8.3	14,500	3801257
	CA*F3636*6C*+TXV	A*V80704B**	23,600	17,700	14.5	12.2	21,800	17,400	23,000	8.3	14,500	3801256
	CA*F3636*6C*+TXV	MBE1600**-1B*	24,000	18,000	15.0	13.0	22,200	17,800	22,000	8.5	12,000	3801255
	CA*F3636*6C*+TXV	MBE1200**-1B*	24,000	18,000	15.0	12.5	22,200	17,800	24,000	8.5	14,500	3801254
	CA*F3636*6C*+TXV	MBR0800**-1	24,000	18,000	14.0	12.0	22,200	17,800	24,000	8.3	14,500	3569091
	CA*F3636*6D*+EEP+TXV		24,000	18,000	14.0	12.5	22,200	17,800	24,000	8.3	14,000	4392733
CA*F3636*6D*+TXV	G*VC950714CXA*	23,600	17,700	15.0	12.5	21,800	17,400	23,000	8.2	14,500	4392743	
CA*F3636*6D*+TXV	G*VC950704CXA*	23,600	17,700	15.0	12.5	21,800	17,400	23,000	8.3	14,500	4392742	

See Notes on Page 33.

AHRI RATINGS (CONT.)

OUTDOOR UNIT	INDOOR UNITS		COOLING CAPACITY				TVA RATINGS ³		HEATING CAPACITY			AHRI #
	COIL & BLOWER UNITS	FURNACE	TOTAL	SENS.	SEER ¹	EER ²	TOTAL	SENS.	HIGH	HSPF ⁴	LOW	
ASZ14 0241A* (cont.)	CA*F3636*6D*+TXV	G*VC950453BXA*	23,600	17,700	14.5	12.2	21,800	17,400	23,600	8.3	14,500	4392741
	CA*F3636*6D*+TXV	A*VC950714CXA*	23,600	17,700	15.0	12.5	21,800	17,400	23,000	8.2	14,500	4392740
	CA*F3636*6D*+TXV	A*VC950704CXA*	23,600	17,700	15.0	12.5	21,800	17,400	23,000	8.3	14,500	4392739
	CA*F3636*6D*+TXV	A*VC950453BXA*	23,600	17,700	14.5	12.2	21,800	17,400	23,600	8.3	14,500	4392738
	CA*F3636*6D*+TXV	A*VC90704CXA*	23,600	17,700	15.0	12.5	21,800	17,400	23,000	8.3	14,500	4392737
	CA*F3636*6D*+TXV	MBVC1600**-1A*	24,000	18,000	15.0	13.0	22,200	17,800	22,000	8.5	12,000	4392736
	CA*F3636*6D*+TXV	MBVC1200**-1A*	24,000	18,000	15.0	12.5	22,200	17,800	24,000	8.5	14,500	4392735
	CA*F3636*6D*+TXV	MBR0800**-1	24,000	18,000	14.0	12.0	22,200	17,800	24,000	8.3	14,500	4392734
	CHPF3636B6B*+EEP+TXV		24,000	18,000	14.0	12.0	22,200	17,800	24,000	8.5	12,000	1330183
	CHPF3636B6B*+TXV	A*VC950453BXA*	24,000	18,000	14.5	12.2	22,200	17,800	24,000	8.3	14,500	3597189
	CHPF3636B6B*+TXV	MBR0800**-1A*	24,000	18,000	14.0	12.0	22,200	17,800	24,000	8.5	14,500	1330209
	CHPF3636B6B*+TXV	A*V90453B**	24,000	18,000	14.5	12.2	22,200	17,800	24,000	8.3	14,500	1330185
	CHPF3636B6B*+TXV	A*V80704B**	24,000	18,000	14.5	12.2	22,200	17,800	24,000	8.3	14,500	1330184
	CHPF3636B6B*+TXV	MBE1200**-1A*	24,000	18,000	15.0	12.0	22,200	17,800	24,000	8.5	14,500	1330182
	CHPF3636B6C*+EEP+TXV		24,000	18,000	14.0	12.0	22,200	17,800	24,000	8.5	12,000	3299340
	CHPF3636B6C*+TXV	MBVC1200**-1A*	24,000	18,000	15.0	12.0	22,200	17,800	24,000	8.5	14,500	3674549
	CHPF3636B6C*+TXV	A*VC950453BXA*	24,000	18,000	14.5	12.2	22,200	17,800	24,000	8.3	14,500	3597190
	CHPF3636B6C*+TXV	A*V90453B**	24,000	18,000	14.5	12.2	22,200	17,800	24,000	8.3	14,500	3299344
	CHPF3636B6C*+TXV	A*V80704B**	24,000	18,000	14.5	12.2	22,200	17,800	24,000	8.3	14,500	3299343
	CHPF3636B6C*+TXV	MBR0800**-1	24,000	18,000	14.0	12.0	22,200	17,800	24,000	8.5	14,500	3299342
	CHPF3636B6C*+TXV	MBE1200**-1B*	24,000	18,000	15.0	12.0	22,200	17,800	24,000	8.5	14,500	3299341
	CHPF3642C6C*+TXV	MBVC1600**-1A*	24,000	18,000	15.0	12.5	22,200	17,800	22,000	8.5	12,000	3674553
	CHPF3642C6C*+TXV	MBE1600**-1B*	24,000	18,000	15.0	12.5	22,200	17,800	22,000	8.5	12,000	3606071
	CSCF3036N6B*+TXV	A*VC950453BXA*	24,000	18,000	14.5	12.2	22,200	17,800	24,000	8.3	14,500	3597188
CSCF3036N6B*+TXV	A*V90453B**	24,000	18,000	14.5	12.2	22,200	17,800	24,000	8.3	14,500	1296573	
CSCF3036N6B*+TXV	A*V80704B**	24,000	18,000	14.5	12.2	22,200	17,800	24,000	8.3	14,500	1296572	
ASZ14 0301A*	AEPF303616C*+TXV		30,000	23,400	15.0	13.0	27,800	23,400	28,000	8.5	18,000	1444013
	AEPF313716A*+TXV		30,000	23,400	15.0	13.0	27,800	23,400	28,000	8.5	18,000	3323252
	AR*F193116B*+TXV		28,800	22,500	14.0	12.0	26,600	22,300	27,000	8.5	18,000	1492739
	AR*F193116C*+TXV		28,800	22,500	14.0	12.0	26,600	22,300	27,000	8.3	16,000	4261908
	ASPF303616B*+TXV		30,000	23,400	15.0	13.0	27,800	23,400	28,000	8.5	18,000	1444022
	ASPF313716A*+TXV		30,000	23,400	15.0	13.0	27,800	23,400	28,000	8.5	18,000	3323256
	ASPF313716C*+TXV		30,000	23,400	15.0	13.0	27,800	23,400	28,000	8.5	18,000	4355494
	ASPF313716D*+TXV		30,000	23,400	15.0	13.0	27,800	23,400	28,000	8.5	18,000	4149371
	ASPF313716E*+TXV		30,000	23,400	15.0	13.0	27,800	23,400	28,000	8.5	18,000	4355500
	AVPTC313714A*		30,000	23,400	15.0	13.0	27,800	23,400	28,000	8.5	18,000	4431362
	AWUF31XX16A*		28,800	22,500	14.0	12.0	26,600	22,300	28,000	8.5	18,000	4393002
	AWUF31XX16A*+TXV		28,800	22,500	14.5	12.3	26,600	22,300	28,000	8.5	18,000	4393003
	AWUF32XX16A*		28,800	22,500	14.0	12.0	26,600	22,300	28,000	8.5	18,000	4393004
	AWUF32XX16A*+TXV		28,800	22,500	14.5	12.3	26,600	22,300	28,000	8.5	18,000	4393005
	CA*F3636*6B*+TXV	MBVC1200**-1A*	28,800	22,500	15.0	13.0	26,600	22,300	28,800	9.0	18,000	3928978
	CA*F3636*6B*+TXV	A*V80703B**	28,800	22,500	15.0	12.5	26,600	22,300	28,800	9.0	18,000	3606072
	CA*F3636*6B*+TXV	G*VC950704CXA*	28,800	22,500	15.0	12.5	26,600	22,300	28,800	8.5	18,000	3597418
	CA*F3636*6B*+TXV	A*VC950704CXA*	28,800	22,500	15.0	12.5	26,600	22,300	28,800	8.5	18,000	3597231
	CA*F3636*6B*+TXV	A*VC950453BXA*	28,800	22,500	15.0	12.5	26,600	22,300	28,800	9.0	18,000	3597202
	CA*F3636*6B*+TXV	A*VC90704CXA*	28,800	22,500	15.0	12.5	26,600	22,300	28,800	8.5	18,000	3597060
	CA*F3636*6B*+TXV	G*V950704C**	28,800	22,500	15.0	12.5	26,600	22,300	28,800	8.5	18,000	3043664
	CA*F3636*6B*+TXV	A*V90704C**	28,800	22,500	15.0	12.5	26,600	22,300	28,800	8.5	18,000	1347338
	CA*F3636*6B*+TXV	A*V90453B**	28,800	22,500	15.0	12.5	26,600	22,300	28,800	9.0	18,000	1347337
	CA*F3636*6B*+TXV	A*V80704B**	28,800	22,500	15.0	12.5	26,600	22,300	28,800	9.0	18,000	1346977
CA*F3636*6B*+TXV	MBE1200**-1	28,800	22,500	15.0	13.0	26,600	22,300	28,800	9.0	18,000	1346976	
CA*F3636*6C*+TXV	A*VC80703BXA*	28,800	22,500	15.0	12.5	26,600	22,300	28,800	8.7	18,000	4402148	

See Notes on Page 33.

AHRI RATINGS (CONT.)

OUTDOOR UNIT	INDOOR UNITS		COOLING CAPACITY				TVA RATINGS ³		HEATING CAPACITY			AHRI #
	COIL & BLOWER UNITS	FURNACE	TOTAL	SENS.	SEER ¹	EER ²	TOTAL	SENS.	HIGH	HSPF ⁴	LOW	
ASZ14 0301A* (cont.)	CA*F3636*6C*+TXV	A*VC950714CXA*	28,800	22,500	15.0	12.5	26,600	22,300	28,800	8.5	18,000	4185032
	CA*F3636*6C*+TXV	A*VC950704CXA*	28,800	22,500	15.0	12.5	26,600	22,300	28,800	8.5	18,000	3801366
	CA*F3636*6C*+TXV	A*VC950453BXA*	28,800	22,500	15.0	12.5	26,600	22,300	28,800	9.0	18,000	3801365
	CA*F3636*6C*+TXV	A*VC90704CXA*	28,800	22,500	15.0	12.5	26,600	22,300	28,800	8.5	18,000	3801364
	CA*F3636*6C*+TXV	G*V950704C**	28,800	22,500	15.0	12.5	26,600	22,300	28,800	8.5	18,000	3801264
	CA*F3636*6C*+TXV	A*V90453B**	28,800	22,500	15.0	12.5	26,600	22,300	28,800	9.0	18,000	3801263
	CA*F3636*6C*+TXV	A*V80704B**	28,800	22,500	15.0	12.5	26,600	22,300	28,800	9.0	18,000	3801262
	CA*F3636*6C*+TXV	MBE1200**-1B*	28,800	22,500	15.0	13.0	26,600	22,300	28,800	9.0	18,000	3801261
	CA*F3636*6C*+TXV	A*VC80704BXA*	28,800	22,500	15.0	12.5	26,600	22,300	28,800	9.0	18,000	3642808
	CA*F3636*6C*+TXV	A*V90704C**	28,800	22,500	15.0	12.5	26,600	22,300	28,800	8.5	18,000	3606074
	CA*F3636*6C*+TXV	A*V80703B**	28,800	22,500	15.0	12.5	26,600	22,300	28,800	9.0	18,000	3606073
	CA*F3636*6D*+TXV	A*VC80703BXA*	28,800	22,500	15.0	12.5	26,600	22,300	28,800	8.7	18,000	4402149
	CA*F3636*6D*+TXV	A*VC950714CXA*	28,800	22,500	15.0	12.5	26,600	22,300	28,800	8.5	18,000	4392749
	CA*F3636*6D*+TXV	A*VC950704CXA*	28,800	22,500	15.0	12.5	26,600	22,300	28,800	8.5	18,000	4392748
	CA*F3636*6D*+TXV	A*VC950453BXA*	28,800	22,500	15.0	12.5	26,600	22,300	28,800	9.0	18,000	4392747
	CA*F3636*6D*+TXV	A*VC90704CXA*	28,800	22,500	15.0	12.5	26,600	22,300	28,800	8.5	18,000	4392746
	CA*F3636*6D*+TXV	A*VC80704BXA*	28,800	22,500	15.0	12.5	26,600	22,300	28,800	9.0	18,000	4392745
	CA*F3642*6C*+TXV	MBR1600**-1	28,800	22,500	14.0	12.0	26,600	22,300	29,000	8.5	18,000	3555144
	CA*F3743*6A*+EEP+TXV		28,400	22,200	14.0	12.0	26,300	22,100	28,800	8.5	18,000	1347341
	CA*F3743*6A*+TXV	G*VC950453BXA*	28,800	22,500	15.0	12.5	26,600	22,300	28,000	9.0	18,000	4393009
	CA*F3743*6A*+TXV	A*VC950453BXA*	28,800	22,500	15.0	12.5	26,600	22,300	28,000	9.0	18,000	4393008
	CA*F3743*6A*+TXV	G*VC950704CXA*	28,800	22,500	15.0	12.5	26,600	22,300	28,000	8.5	18,000	4393007
	CA*F3743*6A*+TXV	A*VC950704CXA*	28,800	22,500	15.0	12.5	26,600	22,300	28,000	8.5	18,000	4393006
	CA*F3743*6A*+TXV	MBVC1600**-1A*	28,800	22,500	15.0	12.5	26,600	22,300	29,000	8.5	18,000	3674524
	CA*F3743*6A*+TXV	A*VC80905CXA*	28,800	22,500	14.5	12.2	26,600	22,300	29,000	8.5	18,000	3642809
	CA*F3743*6A*+TXV	A*V81155C**	28,800	22,500	14.5	12.2	26,600	22,300	29,000	8.5	18,000	1346981
	CA*F3743*6A*+TXV	A*V80905C**	28,800	22,500	14.5	12.2	26,600	22,300	29,000	8.5	18,000	1346980
	CA*F3743*6A*+TXV	MBR1600**-1	28,800	22,500	14.0	12.0	26,600	22,300	29,000	8.5	18,000	1346979
	CA*F3743*6A*+TXV	MBE1600**-1	28,800	22,500	15.0	12.5	26,600	22,300	29,000	8.5	18,000	1346978
	CA*F3743*6D*+EEP+TXV		28,400	22,200	14.0	12.0	26,300	22,100	28,200	8.5	18,000	4415358
	CA*F3743*6D*+TXV	A*VC80905CXA*	28,800	22,500	14.5	12.2	26,600	22,300	27,400	8.5	18,000	4415360
	CA*F3743*6D*+TXV	MBVC1600**-1A*	28,800	22,500	15.0	12.5	26,600	22,300	27,400	8.5	18,000	4415359
	CHPF3636B6B*+TXV	MBE1200**-1A*	30,000	23,400	15.0	13.0	27,800	23,400	28,000	8.5	18,000	1347526
	CHPF3636B6C*+TXV	MBVC1200**-1A*	30,000	23,400	15.0	13.0	27,800	23,400	28,000	8.5	18,000	3674550
	CHPF3636B6C*+TXV	MBE1200**-1B*	30,000	23,400	15.0	13.0	27,800	23,400	28,000	8.5	18,000	3299367
	CHPF3642C6B*+EEP+TXV		28,800	22,500	14.0	12.0	26,600	22,300	29,000	9.0	18,000	1330186
	CHPF3642C6B*+TXV	A*VC950704CXA*	28,800	22,500	14.5	12.2	26,600	22,300	29,000	8.5	18,000	3597230
	CHPF3642C6B*+TXV	A*VC90704CXA*	28,800	22,500	14.5	12.2	26,600	22,300	29,000	8.5	18,000	3597059
	CHPF3642C6B*+TXV	A*V90704C**	28,800	22,500	14.5	12.2	26,600	22,300	29,000	8.5	18,000	1330191
	CHPF3642C6B*+TXV	A*V81155C**	28,800	22,500	14.5	12.2	26,600	22,300	29,000	8.5	18,000	1330190
	CHPF3642C6B*+TXV	A*V80905C**	28,800	22,500	14.5	12.2	26,600	22,300	29,000	8.5	18,000	1330189
	CHPF3642C6B*+TXV	MBR1600**-1A*	28,800	22,500	14.0	12.0	26,600	22,300	29,000	9.0	18,000	1330188
	CHPF3642C6B*+TXV	MBE1600**-1A*	28,800	22,500	15.0	12.5	26,600	22,300	29,000	9.0	18,000	1330187
	CHPF3642C6C*+EEP+TXV		28,800	22,500	14.0	12.0	26,600	22,300	29,000	9.0	18,000	3299368
	CHPF3642C6C*+TXV	A*VC950714CXA*	28,800	22,500	14.5	12.2	26,600	22,300	29,000	8.2	18,000	4185033
	CHPF3642C6C*+TXV	MBVC1600**-1A*	30,000	23,400	15.0	13.0	27,800	23,400	28,000	8.5	18,000	3928979
	CHPF3642C6C*+TXV	MBVC1600**-1A*	28,800	22,500	15.0	12.5	26,600	22,300	29,000	9.0	18,000	3674554
	CHPF3642C6C*+TXV	A*VC80905CXA*	28,800	22,500	14.5	12.2	26,600	22,300	29,000	8.5	18,000	3642810
CHPF3642C6C*+TXV	A*VC950704CXA*	28,800	22,500	14.5	12.2	26,600	22,300	29,000	8.5	18,000	3597232	
CHPF3642C6C*+TXV	A*VC90704CXA*	28,800	22,500	14.5	12.2	26,600	22,300	29,000	8.5	18,000	3597061	
CHPF3642C6C*+TXV	MBE1200**-1B*	30,000	23,400	15.0	13.0	27,800	23,400	28,000	8.5	18,000	3299374	
CHPF3642C6C*+TXV	A*V90704C**	28,800	22,500	14.5	12.2	26,600	22,300	29,000	8.5	18,000	3299373	

See Notes on Page 33.

AHRI RATINGS (CONT.)

OUTDOOR UNIT	INDOOR UNITS		COOLING CAPACITY				TVA RATINGS ³		HEATING CAPACITY			AHRI #
	COIL & BLOWER UNITS	FURNACE	TOTAL	SENS.	SEER ¹	EER ²	TOTAL	SENS.	HIGH	HSPF ⁴	LOW	
ASZ14 0301A* (cont.)	CHPF3642C6C*+TXV	A*V81155C**	28,800	22,500	14.5	12.2	26,600	22,300	29,000	8.5	18,000	3299372
	CHPF3642C6C*+TXV	A*V80905C**	28,800	22,500	14.5	12.2	26,600	22,300	29,000	8.5	18,000	3299371
	CHPF3642C6C*+TXV	MBR1600**.-1	28,800	22,500	14.0	12.0	26,600	22,300	29,000	9.0	18,000	3299370
	CHPF3642C6C*+TXV	MBE1600**.-1B*	28,800	22,500	15.0	12.5	26,600	22,300	29,000	9.0	18,000	3299369
	CSCF3642N6C*+TXV	A*VC950714CXA*	28,800	22,500	14.5	12.2	26,600	22,300	29,000	8.2	18,000	4185034
	CSCF3642N6C*+TXV	A*VC80905CXA*	28,800	22,500	14.5	12.2	26,600	22,300	29,000	8.5	18,000	3642811
	CSCF3642N6C*+TXV	A*VC950704CXA*	28,800	22,500	14.5	12.2	26,600	22,300	29,000	8.5	18,000	3597229
	CSCF3642N6C*+TXV	A*VC90704CXA*	28,800	22,500	14.5	12.2	26,600	22,300	29,000	8.5	18,000	3597058
	CSCF3642N6C*+TXV	A*V90704C**	28,800	22,500	14.5	12.2	26,600	22,300	29,000	8.5	18,000	1296576
	CSCF3642N6C*+TXV	A*V81155C**	28,800	22,500	14.5	12.2	26,600	22,300	29,000	8.5	18,000	1296575
	CSCF3642N6C*+TXV	A*V80905C**	28,800	22,500	14.5	12.2	26,600	22,300	29,000	8.5	18,000	1296574
	ASZ14 0361A*	AEPF313716A*+TXV		36,000	25,900	15.0	12.5	33,300	25,600	34,600	9.0	23,600
AEPF426016C*+TXV			36,000	25,900	15.0	12.5	33,300	25,600	34,600	9.0	23,600	1492740
AR*F374316B*+TXV			35,000	25,200	14.0	12.0	32,400	24,900	35,000	9.0	24,000	1492742
AR*F374316C*+TXV			35,000	25,200	14.0	12.0	32,400	24,900	35,000	9.0	24,000	4358456
ASPF313716A*+TXV			36,000	25,900	15.0	12.5	33,300	25,600	34,600	9.0	23,600	3323257
ASPF313716C*+TXV			36,000	25,900	15.0	12.5	33,300	25,600	34,600	9.0	23,600	4355495
ASPF313716D*+TXV			36,000	25,900	15.0	12.5	33,300	25,600	34,600	9.0	23,600	4149373
ASPF313716E*+TXV			36,000	25,900	15.0	12.5	33,300	25,600	34,600	9.0	23,600	4355501
ASPF426016B*+TXV			36,000	25,900	15.0	13.0	33,300	25,600	34,600	9.0	23,600	1492743
ASPF426016C*+TXV			36,000	25,900	15.0	13.0	33,300	25,600	34,600	9.0	23,600	4358457
ASPF426016D*+TXV			36,000	25,900	15.0	13.0	33,300	25,600	34,600	9.0	23,600	4149372
ASPF426016E*+TXV			36,000	25,900	15.0	13.0	33,300	25,600	34,600	9.0	23,600	4358458
AVPTC313714A*			36,000	25,900	15.0	12.5	33,300	25,600	34,600	9.0	23,600	4431363
AVPTC426014A*			36,000	25,900	15.0	12.5	33,300	25,600	34,600	9.0	23,600	4431364
CA*F3743*6A*+EEP+TXV			36,000	25,900	14.0	12.0	33,300	25,600	34,600	9.0	24,000	3012172
CA*F3743*6A*+TXV		A*VC80905CXA*	35,000	25,200	15.0	12.5	32,400	24,900	35,000	8.5	21,000	4393010
CA*F3743*6D*+EEP+TXV			36,000	25,900	14.0	12.0	33,300	25,600	34,600	9.0	23,000	4415361
CA*F4860*6B*+TXV		MBR1600**.-1	34,600	24,900	14.0	12.0	32,000	24,600	34,600	8.8	21,600	3555143
CA*F4961*6A*+EEP+TXV			36,000	25,900	14.0	12.0	33,300	25,600	35,000	9.0	24,000	1347342
CA*F4961*6A*+TXV		MBE1600**.-1	35,000	25,200	14.5	12.2	32,400	24,900	35,000	9.0	24,000	1346982
CA*F4961*6A*+TXV		MBE2000**.-1	35,000	25,200	15.0	13.0	32,400	24,900	35,000	9.0	24,000	1346983
CA*F4961*6A*+TXV		MBR1600**.-1	34,600	24,900	14.0	12.0	32,000	24,600	34,600	8.8	21,600	1346984
CA*F4961*6A*+TXV		MBVC1600**.-1A*	35,000	25,200	14.5	12.2	32,400	24,900	35,000	9.0	24,000	3674532
CA*F4961*6A*+TXV		MBVC2000**.-1A*	35,000	25,200	15.0	13.0	32,400	24,900	35,000	9.0	24,000	3674535
CA*F4961*6A*+TXV		A*VC80905CXA*	35,000	25,200	15.0	12.5	32,400	24,900	35,000	8.5	24,000	4393011
CA*F4961*6A*+TXV		G*VC950905CXA*	34,600	24,900	15.0	12.5	32,000	24,600	35,000	8.7	24,000	4185107
CA*F4961*6A*+TXV		A*VC950905CXA*	34,600	24,900	15.0	12.5	32,000	24,600	35,000	8.7	24,000	4185106
CA*F4961*6A*+TXV		G*VC950915DXA*	34,600	24,900	15.0	12.5	32,000	24,600	35,000	8.7	24,000	4185038
CA*F4961*6A*+TXV		G*VC950714CXA*	34,600	24,900	14.5	12.2	32,000	24,600	35,000	8.5	24,000	4185037
CA*F4961*6A*+TXV		A*VC950915DXA*	34,600	24,900	15.0	12.5	32,000	24,600	35,000	8.7	24,000	4185036
CA*F4961*6A*+TXV		A*VC950714CXA*	34,600	24,900	14.5	12.2	32,000	24,600	35,000	8.5	24,000	4185035
CA*F4961*6A*+TXV		A*VC81155CXA*	34,600	24,900	14.5	12.2	32,000	24,600	34,600	9.0	24,000	3642813
CA*F4961*6A*+TXV		G*VC951155DXA*	34,600	24,900	15.0	12.5	32,000	24,600	35,000	9.0	24,000	3597433
CA*F4961*6A*+TXV		G*VC950905DXA*	34,600	24,900	15.0	12.5	32,000	24,600	35,000	9.0	24,000	3597422
CA*F4961*6A*+TXV		G*VC950704CXA*	34,600	24,900	14.5	12.2	32,000	24,600	35,000	9.0	24,000	3597419
CA*F4961*6A*+TXV		A*VC951155DXA*	34,600	24,900	15.0	13.0	32,000	24,600	35,000	9.0	24,000	3597335
CA*F4961*6A*+TXV		A*VC950905DXA*	34,600	24,900	15.0	12.5	32,000	24,600	35,000	9.0	24,000	3597258
CA*F4961*6A*+TXV		A*VC950704CXA*	34,600	24,900	14.5	12.2	32,000	24,600	35,000	9.0	24,000	3597233
CA*F4961*6A*+TXV		A*VC90905DXA*	34,600	24,900	15.0	12.5	32,000	24,600	35,000	9.0	24,000	3597087
CA*F4961*6A*+TXV		A*VC90704CXA*	34,600	24,900	14.5	12.2	32,000	24,600	35,000	9.0	24,000	3597062
CA*F4961*6A*+TXV		G*V951155D**	34,600	24,900	15.0	12.5	32,000	24,600	35,000	9.0	24,000	3560693
CA*F4961*6A*+TXV		G*V950905D**	34,600	24,900	15.0	12.5	32,000	24,600	35,000	9.0	24,000	3560692
CA*F4961*6A*+TXV	G*V950704C**	34,600	24,900	14.5	12.2	32,000	24,600	35,000	9.0	24,000	3043665	

See Notes on Page 33.

AHRI RATINGS (CONT.)

OUTDOOR UNIT	INDOOR UNITS		COOLING CAPACITY				TVA RATINGS ³		HEATING CAPACITY			AHRI #
	COIL & BLOWER UNITS	FURNACE	TOTAL	SENS.	SEER ¹	EER ²	TOTAL	SENS.	HIGH	HSPF ⁴	LOW	
ASZ14 0361A* (cont.)	CA*F4961*6A*+TXV	A*V91155D**	34,600	24,900	15.0	13.0	32,000	24,600	35,000	9.0	24,000	1346989
	CA*F4961*6A*+TXV	A*V90905D**	34,600	24,900	15.0	12.5	32,000	24,600	35,000	9.0	24,000	1346988
	CA*F4961*6A*+TXV	A*V90704C**	34,600	24,900	14.5	12.2	32,000	24,600	35,000	9.0	24,000	1346987
	CA*F4961*6A*+TXV	A*V81155C**	34,600	24,900	14.5	12.2	32,000	24,600	34,600	9.0	24,000	1346986
	CA*F4961*6A*+TXV	A*V80905C**	34,600	24,900	14.5	12.2	32,000	24,600	34,600	9.0	24,000	1346985
	CA*F4961*6D*+EEP+TXV		36,000	25,900	14.0	12.0	33,300	25,600	35,000	9.0	24,000	4431493
	CA*F4961*6D*+TXV	MBR1600**-.1	34,600	24,900	14.0	12.0	32,000	24,600	34,600	8.8	21,600	4431499
	CA*F4961*6D*+TXV	MBVC1600**-.1A*	35,000	25,200	14.5	12.2	32,400	24,900	35,000	9.0	24,000	4431500
	CA*F4961*6D*+TXV	MBVC2000**-.1A*	35,000	25,200	15.0	13.0	32,400	24,900	35,000	9.0	24,000	4431501
	CA*F4961*6D*+TXV	G*VC951155DXA*	34,600	24,900	15.0	12.5	32,000	24,600	35,000	9.0	24,000	4431517
	CA*F4961*6D*+TXV	G*VC950915DXA*	34,600	24,900	15.0	12.5	32,000	24,600	35,000	8.7	24,000	4431516
	CA*F4961*6D*+TXV	G*VC950905DXA*	34,600	24,900	15.0	12.5	32,000	24,600	35,000	9.0	24,000	4431515
	CA*F4961*6D*+TXV	G*VC950905CXA*	34,600	24,900	15.0	12.5	32,000	24,600	35,000	8.7	24,000	4431514
	CA*F4961*6D*+TXV	G*VC950714CXA*	34,600	24,900	14.5	12.2	32,000	24,600	35,000	8.5	24,000	4431513
	CA*F4961*6D*+TXV	G*VC950704CXA*	34,600	24,900	14.5	12.2	32,000	24,600	35,000	9.0	24,000	4431512
	CA*F4961*6D*+TXV	A*VC951155DXA*	34,600	24,900	15.0	13.0	32,000	24,600	35,000	9.0	24,000	4431511
	CA*F4961*6D*+TXV	A*VC950915DXA*	34,600	24,900	15.0	12.5	32,000	24,600	35,000	8.7	24,000	4431510
	CA*F4961*6D*+TXV	A*VC950905DXA*	34,600	24,900	15.0	12.5	32,000	24,600	35,000	9.0	24,000	4431509
	CA*F4961*6D*+TXV	A*VC950905CXA*	34,600	24,900	15.0	12.5	32,000	24,600	35,000	8.7	24,000	4431508
	CA*F4961*6D*+TXV	A*VC950714CXA*	34,600	24,900	14.5	12.2	32,000	24,600	35,000	8.5	24,000	4431507
	CA*F4961*6D*+TXV	A*VC950704CXA*	34,600	24,900	14.5	12.2	32,000	24,600	35,000	9.0	24,000	4431506
	CA*F4961*6D*+TXV	A*VC90905DXA*	34,600	24,900	15.0	12.5	32,000	24,600	35,000	9.0	24,000	4431505
	CA*F4961*6D*+TXV	A*VC90704CXA*	34,600	24,900	14.5	12.2	32,000	24,600	35,000	9.0	24,000	4431504
	CA*F4961*6D*+TXV	A*VC81155CXA*	34,600	24,900	14.5	12.2	32,000	24,600	34,600	9.0	24,000	4431503
	CA*F4961*6D*+TXV	A*VC80905CXA*	35,000	25,200	15.0	12.5	32,400	24,900	35,000	8.5	24,000	4431502
	CHPF3743C6A*+EEP+TXV		36,000	25,900	14.0	12.0	33,300	25,600	34,600	9.0	24,000	1347528
	CHPF3743C6B*+EEP+TXV		36,000	25,900	14.0	12.0	33,300	25,600	34,600	9.0	24,000	3299392
	CHPF4860D6C*+EEP+TXV		35,000	25,200	14.0	12.0	32,400	24,900	35,000	9.0	24,000	1330210
	CHPF4860D6C*+TXV	MBE2000**-.1A*	35,000	25,200	15.0	13.0	32,400	24,900	35,000	9.0	24,000	1330192
	CHPF4860D6C*+TXV	A*VC951155DXA*	34,600	24,900	15.0	12.5	32,000	24,600	35,000	9.0	24,000	3597333
	CHPF4860D6C*+TXV	A*VC950905DXA*	34,600	24,900	15.0	13.0	32,000	24,600	35,000	9.0	24,000	3597259
	CHPF4860D6C*+TXV	A*VC90905DXA*	34,600	24,900	15.0	13.0	32,000	24,600	35,000	9.0	24,000	3597088
	CHPF4860D6C*+TXV	A*V91155D**	34,600	24,900	15.0	12.5	32,000	24,600	35,000	9.0	24,000	1330194
	CHPF4860D6C*+TXV	A*V90905D**	34,600	24,900	15.0	13.0	32,000	24,600	35,000	9.0	24,000	1330193
	CHPF4860D6D*+EEP+TXV		35,000	25,200	14.0	12.0	32,400	24,900	35,000	9.0	24,000	3299393
	CHPF4860D6D*+TXV	MBE2000**-.1B*	35,000	25,200	15.0	13.0	32,400	24,900	35,000	9.0	24,000	3299394
	CHPF4860D6D*+TXV	MBVC2000**-.1A*	35,000	25,200	15.0	13.0	32,400	24,900	35,000	9.0	24,000	3674564
	CHPF4860D6D*+TXV	G*VC950915DXA*	34,600	24,900	15.0	13.0	32,000	24,600	35,000	8.7	24,000	4594908
	CHPF4860D6D*+TXV	A*VC950905CXA*	34,600	24,900	15.0	13.0	32,000	24,600	35,000	8.7	24,000	4185108
	CHPF4860D6D*+TXV	A*VC950915DXA*	34,600	24,900	15.0	13.0	32,000	24,600	35,000	8.7	24,000	4185039
	CHPF4860D6D*+TXV	A*VC951155DXA*	34,600	24,900	15.0	12.5	32,000	24,600	35,000	9.0	24,000	3597334
	CHPF4860D6D*+TXV	A*VC950905DXA*	34,600	24,900	15.0	13.0	32,000	24,600	35,000	9.0	24,000	3597260
	CHPF4860D6D*+TXV	A*VC90905DXA*	34,600	24,900	15.0	13.0	32,000	24,600	35,000	9.0	24,000	3597089
	CHPF4860D6D*+TXV	A*V91155D**	34,600	24,900	15.0	12.5	32,000	24,600	35,000	9.0	24,000	3299396
	CHPF4860D6D*+TXV	A*V90905D**	34,600	24,900	15.0	13.0	32,000	24,600	35,000	9.0	24,000	3299395
	CSCF4860N6C*+TXV	G*VC950915DXA*	34,600	24,900	15.0	12.5	32,000	24,600	35,000	8.7	24,000	4594909
	CSCF4860N6C*+TXV	A*VC950905CXA*	34,600	24,900	15.0	12.5	32,000	24,600	35,000	8.7	24,000	4185109
	CSCF4860N6C*+TXV	A*VC950915DXA*	34,600	24,900	15.0	12.5	32,000	24,600	35,000	8.7	24,000	4185040
	CSCF4860N6C*+TXV	A*VC951155DXA*	34,600	24,900	15.0	12.5	32,000	24,600	35,000	9.0	24,000	3597332
	CSCF4860N6C*+TXV	A*VC950905DXA*	34,600	24,900	15.0	12.5	32,000	24,600	35,000	9.0	24,000	3597257
CSCF4860N6C*+TXV	A*VC90905DXA*	34,600	24,900	15.0	12.5	32,000	24,600	35,000	9.0	24,000	3597086	
CSCF4860N6C*+TXV	A*V91155D**	34,600	24,900	15.0	12.5	32,000	24,600	35,000	9.0	24,000	1296578	
CSCF4860N6C*+TXV	A*V90905D**	34,600	24,900	15.0	12.5	32,000	24,600	35,000	9.0	24,000	1296577	

See Notes on Page 33.

AHRI RATINGS (CONT.)

OUTDOOR UNIT	INDOOR UNITS		COOLING CAPACITY				TVA RATINGS ³		HEATING CAPACITY			AHRI #
	COIL & BLOWER UNITS	FURNACE	TOTAL	SENS.	SEER ¹	EER ²	TOTAL	SENS.	HIGH	HSPF ⁴	LOW	
ASZ14 0361B*	AEPF313716A*		34,800	25,100	15.0	13.0	32,200	24,800	33,000	8.9	20,000	4308870
	AEPF313716A*+TXV		35,400	25,500	15.0	12.7	32,700	25,200	33,000	8.9	20,000	4308871
	AEPF426016C*		35,400	25,500	15.0	13.0	32,700	25,200	33,400	9.0	20,000	4308872
	AEPF426016C*+TXV		35,400	25,500	15.0	13.0	32,700	25,200	33,400	9.0	20,000	4308873
	AR*F374316B*		35,000	25,200	14.0	12.0	32,400	24,900	33,400	8.7	20,000	4308874
	AR*F374316B*+TXV		35,000	25,200	14.0	12.0	32,400	24,900	33,000	8.7	20,000	4308875
	ASPF313716A*		35,000	25,200	15.0	12.5	32,400	24,900	33,000	9.0	20,000	4308876
	ASPF313716A*+TXV		35,000	25,200	15.0	12.5	32,400	24,900	33,000	9.0	20,000	4308877
	ASPF313716C*		35,000	25,200	15.0	12.5	32,400	24,900	33,000	9.0	20,000	4355496
	ASPF313716C*+TXV		35,000	25,200	15.0	12.5	32,400	24,900	33,000	9.0	20,000	4355497
	ASPF313716D*		35,000	25,200	15.0	12.5	32,400	24,900	33,000	9.0	20,000	4308878
	ASPF313716D*+TXV		35,000	25,200	15.0	12.5	32,400	24,900	33,000	9.0	20,000	4308879
	ASPF313716E*		35,000	25,200	15.0	12.5	32,400	24,900	33,000	9.0	20,000	4355502
	ASPF313716E*+TXV		35,000	25,200	15.0	12.5	32,400	24,900	33,000	9.0	20,000	4355503
	ASPF426016B*		35,400	25,500	15.0	13.0	32,700	25,200	33,000	9.0	20,000	4308880
	ASPF426016B*+TXV		35,400	25,500	15.0	13.0	32,700	25,200	33,000	9.0	20,000	4308881
	ASPF426016D*		35,400	25,500	15.0	13.0	32,700	25,200	33,000	9.0	20,000	4308882
	ASPF426016D*+TXV		35,400	25,500	15.0	13.0	32,700	25,200	33,000	9.0	20,000	4308883
	AVPTC313714A*		34,800	25,100	15.0	13.0	32,200	24,800	33,000	8.9	20,000	4431373
	AVPTC426014A*		35,400	25,500	15.0	13.0	32,700	25,200	33,400	9.0	20,000	4431374
	CA*F4961*6A*	A*VC950915DXA*	35,000	25,200	15.0	12.5	32,400	24,900	33,400	8.7	20,000	4594891
	CA*F4961*6A*	MBVC2000**-1A*	35,000	25,200	15.0	13.0	32,400	24,900	33,000	9.0	20,000	4308892
	CA*F4961*6A*	MBVC1600**-1A*	35,000	25,200	14.5	12.2	32,400	24,900	33,000	9.0	20,000	4308890
	CA*F4961*6A*	MBR1600**-1	34,600	24,900	14.0	12.0	32,000	24,600	33,400	8.5	20,000	4308888
	CA*F4961*6A*	MBE2000**-1	35,000	25,200	15.0	13.0	32,400	24,900	33,000	9.0	20,000	4308886
	CA*F4961*6A*	MBE1600**-1	35,000	25,200	14.5	12.2	32,400	24,900	33,400	8.8	20,000	4308884
	CA*F4961*6A*	G*E80905C**	34,600	24,900	14.5	12.2	32,000	24,600	33,400	8.5	20,000	4308802
	CA*F4961*6A*	G*VC951155DXA*	35,000	25,200	15.0	12.5	32,400	24,900	33,400	8.8	20,000	4308801
	CA*F4961*6A*	G*E81155C**	34,600	24,900	14.5	12.2	32,000	24,600	33,400	8.5	20,000	4308800
	CA*F4961*6A*	G*VC950905CXA*	35,000	25,200	15.0	12.5	32,400	24,900	33,400	8.7	20,000	4308799
	CA*F4961*6A*	G*VC950704CXA*	34,600	24,900	14.5	12.2	32,000	24,600	33,400	8.5	20,000	4308798
	CA*F4961*6A*	A*VC90704CXA*	34,600	24,900	14.5	12.2	32,000	24,600	33,400	8.5	20,000	4308797
	CA*F4961*6A*	G*VC950714CXA*	34,600	24,900	14.5	12.2	32,000	24,600	33,400	8.5	20,000	4308796
	CA*F4961*6A*	G*VC90905DXA*	35,000	25,200	15.0	12.5	32,400	24,900	33,400	8.8	20,000	4308795
	CA*F4961*6A*	A*VC950704CXA*	34,600	24,900	14.5	12.2	32,000	24,600	33,400	8.5	20,000	4308794
	CA*F4961*6A*	G*VC950915DXA*	35,000	25,200	15.0	12.5	32,400	24,900	33,400	8.7	20,000	4308793
	CA*F4961*6A*	A*VC950714CXA*	34,600	24,900	14.5	12.2	32,000	24,600	33,400	8.5	20,000	4308792
	CA*F4961*6A*	G*VC950905DXA*	35,000	25,200	15.0	12.5	32,400	24,900	33,400	8.9	20,000	4308791
	CA*F4961*6A*+EEP		34,800	25,100	14.0	12.0	32,200	24,800	33,400	8.5	20,000	4308803
	CA*F4961*6A*+EEP+TXV		35,000	25,200	14.0	12.0	32,400	24,900	33,400	8.5	20,000	4308804
	CA*F4961*6A*+TXV	A*VC950915DXA*	35,000	25,200	15.0	12.5	32,400	24,900	33,400	8.8	20,000	4594892
	CA*F4961*6A*+TXV	MBVC2000**-1A*	35,000	25,200	15.0	13.0	32,400	24,900	33,000	9.0	20,000	4308893
	CA*F4961*6A*+TXV	MBVC1600**-1A*	35,000	25,200	14.5	12.2	32,400	24,900	33,000	9.0	20,000	4308891
	CA*F4961*6A*+TXV	MBR1600**-1	34,600	24,900	14.0	12.0	32,000	24,600	33,400	8.5	20,000	4308889
	CA*F4961*6A*+TXV	MBE2000**-1	35,000	25,200	15.0	13.0	32,400	24,900	33,000	9.0	20,000	4308887
	CA*F4961*6A*+TXV	MBE1600**-1	35,000	25,200	14.5	12.2	32,400	24,900	33,400	8.8	20,000	4308885
CA*F4961*6A*+TXV	G*VC951155DXA*	35,000	25,200	15.0	12.5	32,400	24,900	33,400	8.8	20,000	4308817	
CA*F4961*6A*+TXV	G*VC90905DXA*	35,000	25,200	15.0	12.5	32,400	24,900	33,400	8.8	20,000	4308816	
CA*F4961*6A*+TXV	G*E81155C**	34,600	24,900	14.5	12.2	32,000	24,600	33,400	8.5	20,000	4308815	
CA*F4961*6A*+TXV	G*VC950915DXA*	35,000	25,200	15.0	12.5	32,400	24,900	33,400	8.8	20,000	4308814	
CA*F4961*6A*+TXV	A*VC950714CXA*	34,600	24,900	14.5	12.2	32,000	24,600	33,400	8.5	20,000	4308813	
CA*F4961*6A*+TXV	G*E80704B**	34,000	24,500	14.5	12.0	31,500	24,300	33,000	8.8	20,000	4308812	
CA*F4961*6A*+TXV	G*VC950905CXA*	35,000	25,200	15.0	12.5	32,400	24,900	33,400	8.7	20,000	4308811	

See Notes on Page 33.

AHRI RATINGS (CONT.)

OUTDOOR UNIT	INDOOR UNITS		COOLING CAPACITY				TVA RATINGS ³		HEATING CAPACITY			AHRI #
	COIL & BLOWER UNITS	FURNACE	TOTAL	SENS.	SEER ¹	EER ²	TOTAL	SENS.	HIGH	HSPF ⁴	LOW	
ASZ14 0361B* (cont.)	CA*F4961*6A*+TXV	A*VC950704CXA*	34,600	24,900	14.5	12.2	32,000	24,600	33,400	8.5	20,000	4308810
	CA*F4961*6A*+TXV	G*E80905C**	34,600	24,900	14.5	12.2	32,000	24,600	33,400	8.5	20,000	4308809
	CA*F4961*6A*+TXV	G*VC950905DXA*	35,000	25,200	15.0	12.5	32,400	24,900	33,400	8.9	20,000	4308808
	CA*F4961*6A*+TXV	A*VC90704CXA*	34,600	24,900	14.5	12.2	32,000	24,600	33,400	8.5	20,000	4308807
	CA*F4961*6A*+TXV	G*VC950714CXA*	34,600	24,900	14.5	12.2	32,000	24,600	33,400	8.5	20,000	4308806
	CA*F4961*6A*+TXV	G*VC950704CXA*	34,600	24,900	14.5	12.2	32,000	24,600	33,400	8.5	20,000	4308805
	CA*F4961*6D*	A*VC950915DXA*	35,000	25,200	15.0	12.5	32,400	24,900	33,400	8.7	20,000	4594893
	CA*F4961*6D*	MBVC2000**-1A*	35,000	25,200	15.0	13.0	32,400	24,900	33,000	9.0	20,000	4431534
	CA*F4961*6D*	MBVC1600**-1A*	35,000	25,200	14.5	12.2	32,400	24,900	33,000	9.0	20,000	4431532
	CA*F4961*6D*	MBR1600**-1	34,600	24,900	14.0	12.0	32,000	24,600	33,400	8.5	20,000	4431530
	CA*F4961*6D*	G*VC951155DXA*	35,000	25,200	15.0	12.5	32,400	24,900	33,400	8.8	20,000	4431529
	CA*F4961*6D*	G*VC950915DXA*	35,000	25,200	15.0	12.5	32,400	24,900	33,400	8.7	20,000	4431528
	CA*F4961*6D*	G*VC950905DXA*	35,000	25,200	15.0	12.5	32,400	24,900	33,400	8.9	20,000	4431527
	CA*F4961*6D*	G*VC950905CXA*	35,000	25,200	15.0	12.5	32,400	24,900	33,400	8.7	20,000	4431526
	CA*F4961*6D*	G*VC950714CXA*	34,600	24,900	14.5	12.2	32,000	24,600	33,400	8.5	20,000	4431525
	CA*F4961*6D*	G*VC950704CXA*	34,600	24,900	14.5	12.2	32,000	24,600	33,400	8.5	20,000	4431524
	CA*F4961*6D*	G*VC90905DXA*	35,000	25,200	15.0	12.5	32,400	24,900	33,400	8.8	20,000	4431523
	CA*F4961*6D*	G*E81155C**	34,600	24,900	14.5	12.2	32,000	24,600	33,400	8.5	20,000	4431522
	CA*F4961*6D*	G*E80905C**	34,600	24,900	14.5	12.2	32,000	24,600	33,400	8.5	20,000	4431521
	CA*F4961*6D*	A*VC950714CXA*	34,600	24,900	14.5	12.2	32,000	24,600	33,400	8.5	20,000	4431520
	CA*F4961*6D*	A*VC950704CXA*	34,600	24,900	14.5	12.2	32,000	24,600	33,400	8.5	20,000	4431519
	CA*F4961*6D*	A*VC90704CXA*	34,600	24,900	14.5	12.2	32,000	24,600	33,400	8.5	20,000	4431518
	CA*F4961*6D*+EEP		34,800	25,100	14.0	12.0	32,200	24,800	33,400	8.5	20,000	4431494
	CA*F4961*6D*+EEP+TXV		35,000	25,200	14.0	12.0	32,400	24,900	33,400	8.5	20,000	4431495
	CA*F4961*6D*+TXV	A*VC950915DXA*	35,000	25,200	15.0	12.5	32,400	24,900	33,400	8.8	20,000	4594894
	CA*F4961*6D*+TXV	G*VC951155DXA*	35,000	25,200	15.0	12.5	32,400	24,900	33,400	8.8	20,000	4431548
	CA*F4961*6D*+TXV	G*VC950915DXA*	35,000	25,200	15.0	12.5	32,400	24,900	33,400	8.8	20,000	4431547
	CA*F4961*6D*+TXV	G*VC950905DXA*	35,000	25,200	15.0	12.5	32,400	24,900	33,400	8.9	20,000	4431546
	CA*F4961*6D*+TXV	G*VC950905CXA*	35,000	25,200	15.0	12.5	32,400	24,900	33,400	8.7	20,000	4431545
	CA*F4961*6D*+TXV	G*VC950714CXA*	34,600	24,900	14.5	12.2	32,000	24,600	33,400	8.5	20,000	4431544
	CA*F4961*6D*+TXV	G*VC950704CXA*	34,600	24,900	14.5	12.2	32,000	24,600	33,400	8.5	20,000	4431543
	CA*F4961*6D*+TXV	G*VC90905DXA*	35,000	25,200	15.0	12.5	32,400	24,900	33,400	8.8	20,000	4431542
	CA*F4961*6D*+TXV	G*E81155C**	34,600	24,900	14.5	12.2	32,000	24,600	33,400	8.5	20,000	4431541
	CA*F4961*6D*+TXV	G*E80905C**	34,600	24,900	14.5	12.2	32,000	24,600	33,400	8.5	20,000	4431540
	CA*F4961*6D*+TXV	G*E80704B**	34,000	24,500	14.5	12.0	31,500	24,300	33,000	8.8	20,000	4431539
	CA*F4961*6D*+TXV	A*VC950714CXA*	34,600	24,900	14.5	12.2	32,000	24,600	33,400	8.5	20,000	4431538
	CA*F4961*6D*+TXV	A*VC950704CXA*	34,600	24,900	14.5	12.2	32,000	24,600	33,400	8.5	20,000	4431537
	CA*F4961*6D*+TXV	A*VC90704CXA*	34,600	24,900	14.5	12.2	32,000	24,600	33,400	8.5	20,000	4431536
	CA*F4961*6D*+TXV	MBVC2000**-1A*	35,000	25,200	15.0	13.0	32,400	24,900	33,000	9.0	20,000	4431535
	CA*F4961*6D*+TXV	MBVC1600**-1A*	35,000	25,200	14.5	12.2	32,400	24,900	33,000	9.0	20,000	4431533
	CA*F4961*6D*+TXV	MBR1600**-1	34,600	24,900	14.0	12.0	32,000	24,600	33,400	8.5	20,000	4431531
	CHPF4860D6C*	MBE2000**-1A*	34,600	24,900	15.0	13.0	32,000	24,600	33,000	9.0	20,000	4308894
	CHPF4860D6C*	G*VC90905DXA*	34,600	24,900	15.0	12.5	32,000	24,600	33,400	8.8	20,000	4308821
	CHPF4860D6C*	A*VC951155DXA*	34,600	24,900	15.0	12.5	32,000	24,600	33,400	8.8	20,000	4308820
	CHPF4860D6C*	A*VC90905DXA*	34,600	24,900	15.0	12.5	32,000	24,600	33,400	8.8	20,000	4308819
	CHPF4860D6C*	G*VC951155DXA*	34,600	24,900	15.0	12.5	32,000	24,600	33,400	8.8	20,000	4308818
	CHPF4860D6C*+EEP		34,800	25,100	14.0	12.0	32,200	24,800	33,000	8.5	20,000	4308822
	CHPF4860D6C*+EEP+TXV		35,000	25,200	14.0	12.0	32,400	24,900	33,000	8.5	20,000	4308823
CHPF4860D6C*+TXV	MBE2000**-1A*	34,600	24,900	15.0	13.0	32,000	24,600	33,000	9.0	20,000	4308895	
CHPF4860D6C*+TXV	A*VC951155DXA*	34,600	24,900	15.0	12.5	32,000	24,600	33,400	8.8	20,000	4308827	
CHPF4860D6C*+TXV	G*VC951155DXA*	34,600	24,900	15.0	12.5	32,000	24,600	33,400	8.8	20,000	4308826	
CHPF4860D6C*+TXV	A*VC90905DXA*	34,600	24,900	15.0	12.5	32,000	24,600	33,400	8.8	20,000	4308825	

See Notes on Page 33.

AHRI RATINGS (CONT.)

OUTDOOR UNIT	INDOOR UNITS		COOLING CAPACITY				TVA RATINGS ³		HEATING CAPACITY			AHRI #	
	COIL & BLOWER UNITS	FURNACE	TOTAL	SENS.	SEER ¹	EER ²	TOTAL	SENS.	HIGH	HSPF ⁴	LOW		
ASZ14 0361B* (cont.)	CHPF4860D6C*+TXV	G*VC90905DXA*	34,600	24,900	15.0	12.5	32,000	24,600	33,400	8.8	20,000	4308824	
	CHPF4860D6D*	MBVC2000**-1A*	34,600	24,900	15.0	13.0	32,000	24,600	33,000	9.0	20,000	4308898	
	CHPF4860D6D*	MBE2000**-1B*	34,600	24,900	15.0	13.0	32,000	24,600	33,000	9.0	20,000	4308896	
	CHPF4860D6D*	G*VC950704CXA*	34,600	24,900	15.0	12.5	32,000	24,600	33,400	8.8	20,000	4308835	
	CHPF4860D6D*	G*VC90905DXA*	34,600	24,900	15.0	12.5	32,000	24,600	33,400	8.8	20,000	4308834	
	CHPF4860D6D*	A*VC950704CXA*	34,600	24,900	15.0	12.5	32,000	24,600	33,400	8.8	20,000	4308833	
	CHPF4860D6D*	A*VC90905DXA*	34,600	24,900	15.0	12.5	32,000	24,600	33,400	8.8	20,000	4308832	
	CHPF4860D6D*	G*VC951155DXA*	34,600	24,900	15.0	12.5	32,000	24,600	33,400	8.8	20,000	4308831	
	CHPF4860D6D*	G*VC950714CXA*	34,600	24,900	15.0	12.5	32,000	24,600	33,400	8.5	20,000	4308830	
	CHPF4860D6D*	A*VC950714CXA*	34,600	24,900	15.0	12.5	32,000	24,600	33,400	8.5	20,000	4308829	
	CHPF4860D6D*	A*VC951155DXA*	34,600	24,900	15.0	12.5	32,000	24,600	33,400	8.8	20,000	4308828	
	CHPF4860D6D*+EEP			34,800	25,100	14.0	12.0	32,200	24,800	33,000	8.6	20,000	4308836
	CHPF4860D6D*+EEP+TXV			35,000	25,200	14.0	12.0	32,400	24,900	33,000	8.6	20,000	4308837
	CHPF4860D6D*+TXV	MBVC2000**-1A*		34,600	24,900	15.0	13.0	32,000	24,600	33,000	9.0	20,000	4308899
	CHPF4860D6D*+TXV	MBE2000**-1B*		34,600	24,900	15.0	13.0	32,000	24,600	33,000	9.0	20,000	4308897
	CHPF4860D6D*+TXV	A*VC90905DXA*		34,600	24,900	15.0	12.5	32,000	24,600	33,400	8.8	20,000	4308843
	CHPF4860D6D*+TXV	G*VC90905DXA*		34,600	24,900	15.0	12.5	32,000	24,600	33,400	8.8	20,000	4308842
	CHPF4860D6D*+TXV	A*VC950905DXA*		34,600	24,900	15.0	12.5	32,000	24,600	33,400	8.8	20,000	4308841
	CHPF4860D6D*+TXV	G*VC951155DXA*		34,600	24,900	15.0	12.5	32,000	24,600	33,400	8.8	20,000	4308840
	CHPF4860D6D*+TXV	A*VC951155DXA*		34,600	24,900	15.0	12.5	32,000	24,600	33,400	8.8	20,000	4308839
	CHPF4860D6D*+TXV	G*VC950905DXA*		34,600	24,900	15.0	12.5	32,000	24,600	33,400	8.8	20,000	4308838
	CSCF4860N6C*	G*VC951155DXA*		34,600	24,900	15.0	12.5	32,000	24,600	33,400	8.8	20,000	4308847
	CSCF4860N6C*	A*VC951155DXA*		34,600	24,900	15.0	12.5	32,000	24,600	33,400	8.8	20,000	4308846
	CSCF4860N6C*	A*VC90905DXA*		34,600	24,900	15.0	12.5	32,000	24,600	33,400	8.8	20,000	4308845
	CSCF4860N6C*	G*VC90905DXA*		34,600	24,900	15.0	12.5	32,000	24,600	33,400	8.8	20,000	4308844
	CSCF4860N6C*+TXV	A*VC951155DXA*		34,600	24,900	15.0	12.5	32,000	24,600	33,400	8.8	20,000	4308851
	CSCF4860N6C*+TXV	A*VC90905DXA*		34,600	24,900	15.0	12.5	32,000	24,600	33,400	8.8	20,000	4308850
	CSCF4860N6C*+TXV	G*VC90905DXA*		34,600	24,900	15.0	12.5	32,000	24,600	33,400	8.8	20,000	4308849
	CSCF4860N6C*+TXV	G*VC951155DXA*		34,600	24,900	15.0	12.5	32,000	24,600	33,400	8.8	20,000	4308848
	ASZ14 0421A*	AEPF426016C*+TXV		41,000	31,600	15.0	13.0	37,900	31,100	40,000	9.0	27,400	1492744
AR*F374316B*+TXV			40,000	30,800	14.0	12.0	37,000	30,300	41,000	9.0	25,000	1492745	
AR*F374316C*+TXV			40,000	30,800	14.0	12.0	37,000	30,300	41,000	9.0	25,000	4358459	
ASPF426016B*+TXV			41,000	31,600	15.0	13.0	37,900	31,100	40,000	9.0	27,400	1492746	
ASPF426016C*+TXV			41,000	31,600	15.0	13.0	37,900	31,100	40,000	9.0	27,400	4358460	
ASPF426016D*+TXV			41,000	31,600	15.0	13.0	37,900	31,100	40,000	9.0	27,400	4149374	
ASPF426016E*+TXV			41,000	31,600	15.0	13.0	37,900	31,100	40,000	9.0	27,400	4358461	
AVPTC426014A*			41,000	31,600	15.0	13.0	37,900	31,100	40,000	9.0	27,400	4431365	
CA*F4961*6A*+EEP+TXV			41,000	31,600	14.0	12.0	37,900	31,100	42,000	9.0	27,400	1347343	
CA*F4961*6A*+TXV		MBVC2000**-1A*		40,000	30,800	15.0	13.0	37,000	30,300	41,000	9.0	25,000	3674536
CA*F4961*6A*+TXV		A*VC80905CXA*		40,000	30,800	15.0	12.5	37,000	30,300	41,000	9.0	25,000	3642854
CA*F4961*6A*+TXV		A*VC951155DXA*		40,000	30,800	15.0	13.0	37,000	30,300	41,000	9.0	25,000	3597363
CA*F4961*6A*+TXV		A*VC950905DXA*		40,000	30,800	15.0	12.5	37,000	30,300	41,000	9.0	25,000	3597289
CA*F4961*6A*+TXV		A*VC90905DXA*		40,000	30,800	15.0	12.5	37,000	30,300	41,000	9.0	25,000	3597118
CA*F4961*6A*+TXV		A*V81155C**		40,000	30,800	15.0	12.5	37,000	30,300	41,000	9.0	25,000	3298367
CA*F4961*6A*+TXV		A*V80905C**		40,000	30,800	15.0	12.5	37,000	30,300	41,000	9.0	25,000	3298366
CA*F4961*6A*+TXV		A*V91155D**		40,000	30,800	15.0	13.0	37,000	30,300	41,000	9.0	25,000	1346993
CA*F4961*6A*+TXV		A*V90905D**		40,000	30,800	15.0	12.5	37,000	30,300	41,000	9.0	25,000	1346992
CA*F4961*6A*+TXV		MBR2000**-1		40,000	30,800	14.0	12.0	37,000	30,300	41,000	9.0	25,000	1346991
CA*F4961*6A*+TXV		MBE2000**-1		40,000	30,800	15.0	13.0	37,000	30,300	41,000	9.0	25,000	1346990
CA*F4961*6D*+EEP+TXV			41,000	31,600	14.0	12.0	37,900	31,100	42,000	9.0	27,400	4431496	
CA*F4961*6D*+TXV	A*VC951155DXA*		40,000	30,800	15.0	13.0	37,000	30,300	41,000	9.0	25,000	4431554	
CA*F4961*6D*+TXV	A*VC950905DXA*		40,000	30,800	15.0	12.5	37,000	30,300	41,000	9.0	25,000	4431553	

See Notes on Page 33.

AHRI RATINGS (CONT.)

OUTDOOR UNIT	INDOOR UNITS		COOLING CAPACITY				TVA RATINGS ³		HEATING CAPACITY			AHRI #
	COIL & BLOWER UNITS	FURNACE	TOTAL	SENS.	SEER ¹	EER ²	TOTAL	SENS.	HIGH	HSPF ⁴	LOW	
ASZ14 0421A* (cont.)	CA*F4961*6D*+TXV	A*VC90905DXA*	40,000	30,800	15.0	12.5	37,000	30,300	41,000	9.0	25,000	4431552
	CA*F4961*6D*+TXV	A*VC80905CXA*	40,000	30,800	15.0	12.5	37,000	30,300	41,000	9.0	25,000	4431551
	CA*F4961*6D*+TXV	MBVC2000**-1A*	40,000	30,800	15.0	13.0	37,000	30,300	41,000	9.0	25,000	4431550
	CA*F4961*6D*+TXV	MBR2000**-1	40,000	30,800	14.0	12.0	37,000	30,300	41,000	9.0	25,000	4431549
	CHPF4860D6C*+EEP+TXV		40,000	30,800	14.0	12.0	37,000	30,300	41,000	9.0	27,400	1330198
	CHPF4860D6C*+TXV	MBE2000**-1B*	40,000	30,800	15.0	12.5	37,000	30,300	41,000	8.5	25,000	3606075
	CHPF4860D6C*+TXV	A*VC951155DXA*	40,000	30,800	15.0	13.0	37,000	30,300	41,000	9.0	25,000	3597364
	CHPF4860D6C*+TXV	A*VC950905DXA*	40,000	30,800	15.0	12.5	37,000	30,300	41,000	9.0	25,000	3597288
	CHPF4860D6C*+TXV	A*VC90905DXA*	40,000	30,800	15.0	12.5	37,000	30,300	41,000	9.0	25,000	3597117
	CHPF4860D6C*+TXV	MBR2000**-1A*	40,000	30,800	14.0	12.0	37,000	30,300	41,000	9.0	27,400	1330199
	CHPF4860D6C*+TXV	A*V91155D**	40,000	30,800	15.0	13.0	37,000	30,300	41,000	9.0	25,000	1330197
	CHPF4860D6C*+TXV	A*V90905D**	40,000	30,800	15.0	12.5	37,000	30,300	41,000	9.0	25,000	1330196
	CHPF4860D6C*+TXV	MBE2000**-1A*	40,000	30,800	15.0	13.0	37,000	30,300	41,000	9.0	25,000	1330195
	CHPF4860D6D*+EEP+TXV		40,000	30,800	14.0	12.0	37,000	30,300	41,000	9.0	27,400	3299452
	CHPF4860D6D*+TXV	MBVC2000**-1A*	40,000	30,800	15.0	13.0	37,000	30,300	41,000	9.0	25,000	3674565
	CHPF4860D6D*+TXV	A*VC951155DXA*	40,000	30,800	15.0	13.0	37,000	30,300	41,000	9.0	25,000	3597365
	CHPF4860D6D*+TXV	A*VC950905DXA*	40,000	30,800	15.0	12.5	37,000	30,300	41,000	9.0	25,000	3597290
	CHPF4860D6D*+TXV	A*VC90905DXA*	40,000	30,800	15.0	12.5	37,000	30,300	41,000	9.0	25,000	3597119
	CHPF4860D6D*+TXV	A*V91155D**	40,000	30,800	15.0	13.0	37,000	30,300	41,000	9.0	25,000	3299456
	CHPF4860D6D*+TXV	A*V90905D**	40,000	30,800	15.0	12.5	37,000	30,300	41,000	9.0	25,000	3299455
	CHPF4860D6D*+TXV	MBR2000**-1	40,000	30,800	14.0	12.0	37,000	30,300	41,000	9.0	27,400	3299454
	CHPF4860D6D*+TXV	MBE2000**-1B*	40,000	30,800	15.0	13.0	37,000	30,300	41,000	9.0	25,000	3299453
	CSCF4860N6C*+TXV	A*VC951155DXA*	40,000	30,800	15.0	12.5	37,000	30,300	41,000	9.0	25,000	3597362
	CSCF4860N6C*+TXV	A*VC950905DXA*	40,000	30,800	15.0	12.5	37,000	30,300	41,000	9.0	25,000	3597287
CSCF4860N6C*+TXV	A*VC90905DXA*	40,000	30,800	15.0	12.5	37,000	30,300	41,000	9.0	25,000	3597116	
CSCF4860N6C*+TXV	A*V91155D**	40,000	30,800	15.0	12.5	37,000	30,300	41,000	9.0	25,000	1296580	
CSCF4860N6C*+TXV	A*V90905D**	40,000	30,800	15.0	12.5	37,000	30,300	41,000	9.0	25,000	1296579	
ASZ14 0481A*	AEPF426016C*+TXV		47,000	35,700	15.0	13.0	43,500	35,200	47,000	8.8	30,000	1492747
	AR*F374316B*+TXV		47,000	35,700	14.0	12.0	43,500	35,200	47,000	8.5	30,000	1492748
	AR*F374316C*+TXV		47,000	35,700	14.0	12.0	43,500	35,200	47,000	8.5	30,000	4358462
	AR*F486016B*+TXV		45,000	34,200	13.5	11.5	41,600	33,700	46,000	8.5	30,000	3060424
	AR*F486016C*+TXV		45,000	34,200	13.5	11.5	41,600	33,700	46,000	8.5	30,000	3896020
	ASPF426016B*+TXV		47,000	35,700	15.0	13.0	43,500	35,200	47,000	8.8	30,000	1492749
	ASPF426016C*+TXV		47,000	35,700	15.0	13.0	43,500	35,200	47,000	8.8	30,000	4358463
	ASPF426016D*+TXV		47,000	35,700	15.0	13.0	43,500	35,200	47,000	8.8	30,000	4149375
	ASPF426016E*+TXV		47,000	35,700	15.0	13.0	43,500	35,200	47,000	8.8	30,000	4358464
	AVPTC426014A*		47,000	35,700	15.0	13.0	43,500	35,200	47,000	8.8	30,000	4431366
	CA*F4961*6A*+EEP+TXV		46,000	35,000	14.0	12.0	42,600	34,500	47,500	8.8	30,000	1347344
	CA*F4961*6A*+TXV	G*VC950915DXA*	46,000	35,000	14.5	12.0	42,600	34,500	47,000	8.5	30,000	4594910
	CA*F4961*6A*+TXV	A*VC950905CXA*	46,000	35,000	14.5	12.0	42,600	34,500	47,000	8.5	30,000	4185110
	CA*F4961*6A*+TXV	A*VC950915DXA*	46,000	35,000	14.5	12.0	42,600	34,500	47,000	8.5	30,000	4185041
	CA*F4961*6A*+TXV	A*VC81155CXA*	46,000	35,000	14.5	12.0	42,600	34,500	47,000	8.5	30,000	3707095
	CA*F4961*6A*+TXV	MBVC2000**-1A*	46,000	35,000	15.0	13.0	42,600	34,500	46,000	9.0	30,000	3674537
	CA*F4961*6A*+TXV	A*VC80905CXA*	46,000	35,000	14.5	12.0	42,600	34,500	47,000	8.5	30,000	3642873
	CA*F4961*6A*+TXV	A*VC951155DXA*	46,000	35,000	14.5	12.0	42,600	34,500	47,000	8.5	30,000	3597385
	CA*F4961*6A*+TXV	A*VC950905DXA*	46,000	35,000	14.5	12.0	42,600	34,500	47,000	8.5	30,000	3597310
	CA*F4961*6A*+TXV	A*VC90905DXA*	46,000	35,000	14.5	12.0	42,600	34,500	47,000	8.5	30,000	3597139
CA*F4961*6A*+TXV	A*V81155C**	46,000	35,000	14.5	12.0	42,600	34,500	47,000	8.5	30,000	3407744	
CA*F4961*6A*+TXV	A*V80905C**	46,000	35,000	14.5	12.0	42,600	34,500	47,000	8.5	30,000	3407743	
CA*F4961*6A*+TXV	A*V91155D**	46,000	35,000	14.5	12.0	42,600	34,500	47,000	8.5	30,000	1346997	
CA*F4961*6A*+TXV	A*V90905D**	46,000	35,000	14.5	12.0	42,600	34,500	47,000	8.5	30,000	1346996	
CA*F4961*6A*+TXV	MBR2000**-1	46,000	35,000	14.0	12.0	42,600	34,500	47,000	8.5	30,000	1346995	

See Notes on Page 33.

AHRI RATINGS (CONT.)

OUTDOOR UNIT	INDOOR UNITS		COOLING CAPACITY				TVA RATINGS ³		HEATING CAPACITY			AHRI #
	COIL & BLOWER UNITS	FURNACE	TOTAL	SENS.	SEER ¹	EER ²	TOTAL	SENS.	HIGH	HSPF ⁴	LOW	
ASZ14 0481A* (cont.)	CA*F4961*6A*+TXV	MBE2000**-1	46,000	35,000	15.0	13.0	42,600	34,500	46,000	9.0	30,000	1346994
	CA*F4961*6D*+EEP+TXV		46,000	35,000	14.0	12.0	42,600	34,500	47,500	8.8	30,000	4431497
	CA*F4961*6D*+TXV	G*VC950915DXA*	46,000	35,000	14.5	12.0	42,600	34,500	47,000	8.5	30,000	4594911
	CA*F4961*6D*+TXV	A*VC951155DXA*	46,000	35,000	14.5	12.0	42,600	34,500	47,000	8.5	30,000	4431562
	CA*F4961*6D*+TXV	A*VC950915DXA*	46,000	35,000	14.5	12.0	42,600	34,500	47,000	8.5	30,000	4431561
	CA*F4961*6D*+TXV	A*VC950905DXA*	46,000	35,000	14.5	12.0	42,600	34,500	47,000	8.5	30,000	4431560
	CA*F4961*6D*+TXV	A*VC950905CXA*	46,000	35,000	14.5	12.0	42,600	34,500	47,000	8.5	30,000	4431559
	CA*F4961*6D*+TXV	A*VC90905DXA*	46,000	35,000	14.5	12.0	42,600	34,500	47,000	8.5	30,000	4431558
	CA*F4961*6D*+TXV	A*VC81155CXA*	46,000	35,000	14.5	12.0	42,600	34,500	47,000	8.5	30,000	4431557
	CA*F4961*6D*+TXV	A*VC80905CXA*	46,000	35,000	14.5	12.0	42,600	34,500	47,000	8.5	30,000	4431556
	CA*F4961*6D*+TXV	MBVC2000**-1A*	46,000	35,000	15.0	13.0	42,600	34,500	46,000	9.0	30,000	4431555
	CHPF4860D6C*+EEP+TXV		47,000	35,700	14.0	12.0	43,500	35,200	46,000	9.0	30,000	1330200
	CHPF4860D6C*+TXV	MBVC2000**-1A*	46,000	35,000	15.0	12.5	42,600	34,500	47,000	8.5	30,000	3928980
	CHPF4860D6C*+TXV	A*VC951155DXA*	46,000	35,000	14.5	12.0	42,600	34,500	47,000	8.5	30,000	3597384
	CHPF4860D6C*+TXV	MBE2000**-1B*	46,000	35,000	15.0	12.5	42,600	34,500	47,000	8.5	30,000	1405768
	CHPF4860D6C*+TXV	A*V91155D**	46,000	35,000	14.5	12.0	42,600	34,500	47,000	8.5	30,000	1330202
	CHPF4860D6C*+TXV	MBR2000**-1A*	46,000	35,000	14.5	12.0	42,600	34,500	47,000	8.5	30,000	1330201
	CHPF4860D6D*+EEP+TXV		47,000	35,700	14.0	12.0	43,500	35,200	46,000	9.0	30,000	3299468
	CHPF4860D6D*+TXV	MBVC2000**-1A*	46,000	35,000	14.5	12.0	42,600	34,500	47,000	9.0	30,000	3674566
	CHPF4860D6D*+TXV	A*VC951155DXA*	46,000	35,000	14.5	12.0	42,600	34,500	47,000	8.5	30,000	3597386
	CHPF4860D6D*+TXV	A*V91155D**	46,000	35,000	14.5	12.0	42,600	34,500	47,000	8.5	30,000	3299471
	CHPF4860D6D*+TXV	MBR2000**-1	46,000	35,000	14.5	12.0	42,600	34,500	47,000	8.5	30,000	3299470
	CHPF4860D6D*+TXV	MBE2000**-1B*	46,000	35,000	14.5	12.0	42,600	34,500	47,000	9.0	30,000	3299469
	CSCF4860N6C*+TXV	G*VC950915DXA*	46,000	35,000	14.5	12.0	42,600	34,500	47,000	8.5	30,000	4594912
	CSCF4860N6C*+TXV	A*VC950905CXA*	46,000	35,000	14.5	12.0	42,600	34,500	47,000	8.5	30,000	4185111
	CSCF4860N6C*+TXV	A*VC950915DXA*	46,000	35,000	14.5	12.0	42,600	34,500	47,000	8.5	30,000	4185042
	CSCF4860N6C*+TXV	A*VC951155DXA*	46,000	35,000	14.5	12.0	42,600	34,500	47,000	8.5	30,000	3597383
	CSCF4860N6C*+TXV	A*VC950905DXA*	46,000	35,000	14.5	12.0	42,600	34,500	47,000	8.5	30,000	3597309
	CSCF4860N6C*+TXV	A*VC90905DXA*	46,000	35,000	14.5	12.0	42,600	34,500	47,000	8.5	30,000	3597138
	CSCF4860N6C*+TXV	A*V91155D**	46,000	35,000	14.5	12.0	42,600	34,500	47,000	8.5	30,000	1296582
	CSCF4860N6C*+TXV	A*V90905D**	46,000	35,000	14.5	12.0	42,600	34,500	47,000	8.5	30,000	1296581
	ASZ14 0601A*	AEPF426016C*+TXV		57,000	42,200	14.5	12.0	52,700	41,600	59,000	8.8	39,000
AR*F374316B*+TXV			57,000	42,200	13.5	11.5	52,700	41,600	57,000	8.5	36,000	3019325
AR*F374316C*+TXV			57,000	42,200	13.5	11.5	52,700	41,600	57,000	8.5	36,000	4358465
AR*F496116A*+TXV			57,000	42,200	14.0	12.2	52,700	41,600	57,000	8.5	33,000	1492751
AR*F496116C*+TXV			57,000	42,200	14.0	12.2	52,700	41,600	57,000	8.5	33,000	4358466
ASPF426016B*+TXV			57,000	42,200	14.5	12.0	52,700	41,600	59,000	8.8	39,000	1492752
ASPF426016C*+TXV			57,000	42,200	14.5	12.0	52,700	41,600	59,000	8.8	39,000	4358467
ASPF426016D*+TXV			57,000	42,200	14.5	12.0	52,700	41,600	59,000	8.8	39,000	4149376
ASPF426016E*+TXV			57,000	42,200	14.5	12.0	52,700	41,600	59,000	8.8	39,000	4358468
AVPTC426014A*			57,000	42,200	14.5	12.0	52,700	41,600	59,000	8.8	39,000	4431367
CA*F4961*6A*+EEP+TXV			57,000	42,200	14.0	12.0	52,700	41,600	58,000	9.0	39,000	1347345
CA*F4961*6A*+TXV		G*VC950915DXA*	56,500	41,800	14.0	11.5	52,300	41,300	57,000	8.5	33,000	4594913
CA*F4961*6A*+TXV		A*VC950905CXA*	56,500	41,800	14.0	11.5	52,300	41,300	57,000	8.5	33,000	4185112
CA*F4961*6A*+TXV		A*VC950915DXA*	56,500	41,800	14.0	11.5	52,300	41,300	57,000	8.5	33,000	4185043
CA*F4961*6A*+TXV		MBVC2000**-1A*	56,500	41,800	15.0	12.5	52,300	41,300	57,000	9.0	33,000	3674538
CA*F4961*6A*+TXV		A*VC951155DXA*	56,500	41,800	14.0	11.5	52,300	41,300	57,000	8.5	33,000	3597401
CA*F4961*6A*+TXV		A*VC950905DXA*	56,500	41,800	14.0	11.5	52,300	41,300	57,000	8.5	33,000	3597321
CA*F4961*6A*+TXV		A*VC90905DXA*	56,500	41,800	14.0	11.5	52,300	41,300	57,000	8.5	33,000	3597150
CA*F4961*6A*+TXV		A*V91155D**	56,500	41,800	14.0	11.5	52,300	41,300	57,000	8.5	33,000	1347339
CA*F4961*6A*+TXV		A*V90905D**	56,500	41,800	14.0	11.5	52,300	41,300	57,000	8.5	33,000	1347000
CA*F4961*6A*+TXV	MBR2000**-1	56,500	41,800	14.0	12.0	52,300	41,300	57,000	8.5	33,000	1346999	

See Notes on Page 33.

AHRI RATINGS (CONT.)

OUTDOOR UNIT	INDOOR UNITS		COOLING CAPACITY				TVA RATINGS ³		HEATING CAPACITY			AHRI #
	COIL & BLOWER UNITS	FURNACE	TOTAL	SENS.	SEER ¹	EER ²	TOTAL	SENS.	HIGH	HSPF ⁴	LOW	
ASZ14 0601A* (cont.)	CA*F4961*6A*+TXV	MBE2000**-1	56,500	41,800	15.0	12.5	52,300	41,300	57,000	9.0	33,000	1346998
	CA*F4961*6D*+EEP+TXV		57,000	42,200	14.0	12.0	52,700	41,600	58,000	9.0	39,000	4431498
	CA*F4961*6D*+TXV	G*VC950915DXA*	56,500	41,800	14.0	11.5	52,300	41,300	57,000	8.5	33,000	4594914
	CA*F4961*6D*+TXV	A*VC951155DXA*	56,500	41,800	14.0	11.5	52,300	41,300	57,000	8.5	33,000	4431568
	CA*F4961*6D*+TXV	A*VC950915DXA*	56,500	41,800	14.0	11.5	52,300	41,300	57,000	8.5	33,000	4431567
	CA*F4961*6D*+TXV	A*VC950905DXA*	56,500	41,800	14.0	11.5	52,300	41,300	57,000	8.5	33,000	4431566
	CA*F4961*6D*+TXV	A*VC950905CXA*	56,500	41,800	14.0	11.5	52,300	41,300	57,000	8.5	33,000	4431565
	CA*F4961*6D*+TXV	A*VC90905DXA*	56,500	41,800	14.0	11.5	52,300	41,300	57,000	8.5	33,000	4431564
	CA*F4961*6D*+TXV	MBVC2000**-1A*	56,500	41,800	15.0	12.5	52,300	41,300	57,000	9.0	33,000	4431563
	CHPF4860D6C*+EEP+TXV		57,000	42,200	14.0	12.0	52,700	41,600	58,000	8.8	39,500	1330204
	CHPF4860D6C*+TXV	MBVC2000**-1A*	56,500	41,800	15.0	12.5	52,300	41,300	57,000	9.0	33,000	4587593
	CHPF4860D6C*+TXV	A*VC951155DXA*	56,500	41,800	14.0	11.5	52,300	41,300	57,000	8.5	33,000	3597400
	CHPF4860D6C*+TXV	A*VC950905DXA*	56,500	41,800	14.0	11.5	52,300	41,300	57,000	8.5	33,000	3597320
	CHPF4860D6C*+TXV	A*VC90905DXA*	56,500	41,800	14.0	11.5	52,300	41,300	57,000	8.5	33,000	3597149
	CHPF4860D6C*+TXV	A*V91155D**	56,500	41,800	14.0	11.5	52,300	41,300	57,000	8.5	33,000	1330207
	CHPF4860D6C*+TXV	A*V90905D**	56,500	41,800	14.0	11.5	52,300	41,300	57,000	8.5	33,000	1330206
	CHPF4860D6C*+TXV	MBR2000**-1A*	57,000	42,200	14.0	12.0	52,700	41,600	57,000	8.8	38,000	1330205
	CHPF4860D6C*+TXV	MBE2000**-1A*	56,500	41,800	15.0	12.5	52,300	41,300	57,000	9.0	33,000	1330203
	CHPF4860D6D*+EEP+TXV		57,000	42,200	14.0	12.0	52,700	41,600	58,000	8.8	39,500	3299492
	CHPF4860D6D*+TXV	G*VC950915DXA*	56,500	41,800	14.0	11.5	52,300	41,300	57,000	8.5	33,000	4594915
	CHPF4860D6D*+TXV	A*VC950905CXA*	56,500	41,800	14.0	11.5	52,300	41,300	57,000	8.5	33,000	4185113
	CHPF4860D6D*+TXV	A*VC950915DXA*	56,500	41,800	14.0	11.5	52,300	41,300	57,000	8.5	33,000	4185044
	CHPF4860D6D*+TXV	MBVC2000**-1A*	56,500	41,800	15.0	12.0	52,300	41,300	57,000	8.5	33,000	3674567
	CHPF4860D6D*+TXV	A*VC951155DXA*	56,500	41,800	14.0	11.5	52,300	41,300	57,000	8.5	33,000	3597402
	CHPF4860D6D*+TXV	A*VC950905DXA*	56,500	41,800	14.0	11.5	52,300	41,300	57,000	8.5	33,000	3597322
	CHPF4860D6D*+TXV	A*VC90905DXA*	56,500	41,800	14.0	11.5	52,300	41,300	57,000	8.5	33,000	3597151
	CHPF4860D6D*+TXV	A*V91155D**	56,500	41,800	14.0	11.5	52,300	41,300	57,000	8.5	33,000	3299496
	CHPF4860D6D*+TXV	A*V90905D**	56,500	41,800	14.0	11.5	52,300	41,300	57,000	8.5	33,000	3299495
	CHPF4860D6D*+TXV	MBR2000**-1	57,000	42,200	14.0	12.0	52,700	41,600	57,000	8.8	38,000	3299494
	CHPF4860D6D*+TXV	MBE2000**-1B*	56,500	41,800	15.0	12.5	52,300	41,300	57,000	9.0	33,000	3299493
	CSCF4860N6C*+TXV	G*VC950915DXA*	56,500	41,800	13.5	11.5	52,300	41,300	57,000	8.5	33,000	4594916
	CSCF4860N6C*+TXV	A*VC950905CXA*	56,500	41,800	13.5	11.5	52,300	41,300	57,000	8.5	33,000	4185114
	CSCF4860N6C*+TXV	A*VC950915DXA*	56,500	41,800	13.5	11.5	52,300	41,300	57,000	8.5	33,000	4185045
	CSCF4860N6C*+TXV	A*VC951155DXA*	56,500	41,800	13.5	11.5	52,300	41,300	57,000	8.5	33,000	3597399
	CSCF4860N6C*+TXV	A*VC950905DXA*	56,500	41,800	13.5	11.5	52,300	41,300	57,000	8.5	33,000	3597319
	CSCF4860N6C*+TXV	A*VC90905DXA*	56,500	41,800	13.5	11.5	52,300	41,300	57,000	8.5	33,000	3597148
	CSCF4860N6C*+TXV	A*V91155D**	56,500	41,800	13.5	11.5	52,300	41,300	57,000	8.5	33,000	1296584
	CSCF4860N6C*+TXV	A*V90905D**	56,500	41,800	13.5	11.5	52,300	41,300	57,000	8.5	33,000	1296583

¹ Seasonal Energy Efficiency Ratio; Certified per AHRI 210/240 @ 80°F/ 67°F/ 95°F

² Energy Efficiency Ratio @ 80°F/ 67°F/ 95°F

³ TVA Rating: BTU/h @ 75°F/ 63°F - 95°F

⁴ HSPF = Heating Seasonal Performance Factor

NOTES:

- Always check the S&R plate for electrical data on the unit being installed.
- When matching the outdoor unit to the indoor unit, use the piston supplied with the outdoor unit or that specified on the piston kit chart supplied with the indoor unit.
- EEP - Order from Service Dept. Part No. B13707-38 or new Solid State Board B13707-35S. Part No. B13707-38 is not interchangeable with B13707-35S. The Goodman Gas Furnace contains the EEP cooling time delay

DIMENSIONS

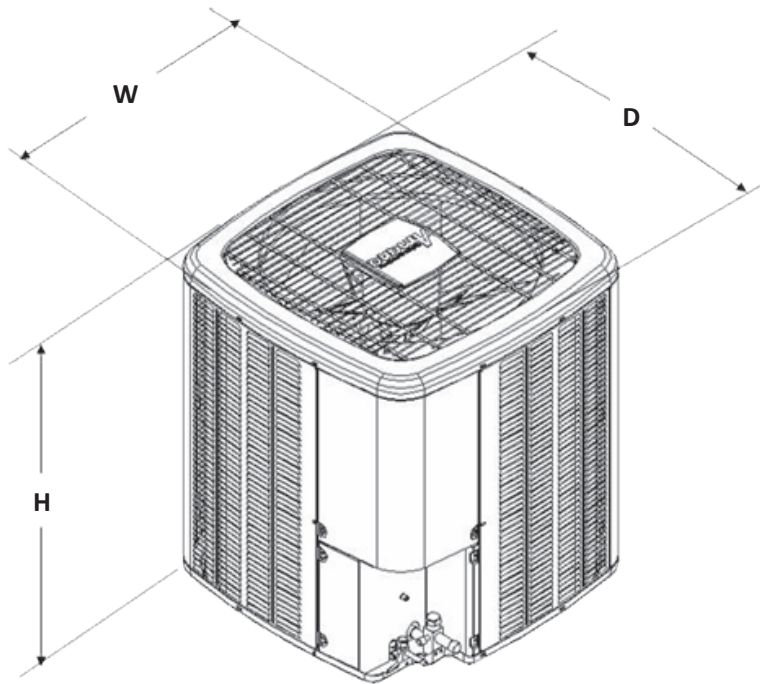

MODEL	DIMENSIONS		
	W"	D"	H"
ASZ140181A	29	29	34 $\frac{1}{4}$
ASZ140241A	29	29	38 $\frac{1}{4}$
ASZ140301A	29	29	38 $\frac{1}{4}$
ASZ140361A	35 $\frac{1}{2}$	35 $\frac{1}{2}$	38 $\frac{1}{4}$
ASZ140361B	29	29	38 $\frac{1}{4}$
ASZ140421A	35 $\frac{1}{2}$	35 $\frac{1}{2}$	38 $\frac{1}{4}$
ASZ140481A	35 $\frac{1}{2}$	35 $\frac{1}{2}$	38 $\frac{1}{4}$
ASZ140601A	35 $\frac{1}{2}$	35 $\frac{1}{2}$	38 $\frac{1}{4}$

WIRING DIAGRAM

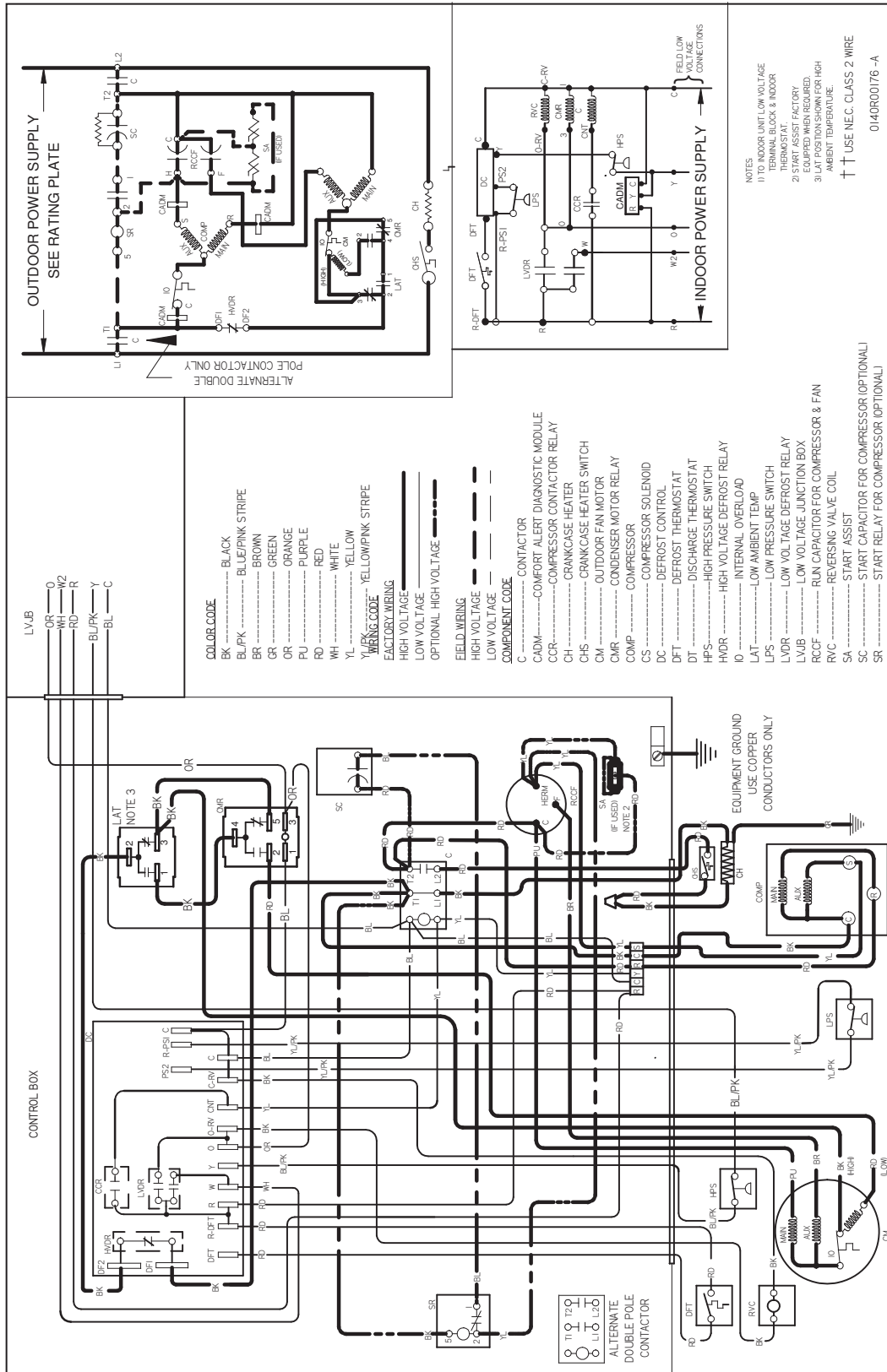

Wiring is subject to change. Always refer to the wiring diagram or the unit for the most up-to-date wiring.

WARNING

High Voltage: Disconnect all power before servicing or installing this unit. Multiple power sources may be present. Failure to do so may cause property damage, personal injury, or death.

ACCESSORIES

MODEL	DESCRIPTION	ASZ14 018	ASZ14 024	ASZ14 030	ASZ14 036	ASZ14 042	ASZ14 048	ASZ14 060
ABK-20	Anchor Bracket Kit [*]	X	X	X	X	X	X	X
ASC01	Anti-Short Cycle Kit	X	X	X	X	X	X	X
CSR-U-1	Hard-start Kit	X	X	X	X			
CSR-U-2	Hard-start Kit				X	X	X	X
CSR-U-3	Hard-start Kit						X	X
FSK01A1	Freeze Protection Kit	X	X	X	X	X	X	X
OT18-60A2	Outdoor Thermostat	X	X	X	X	X	X	X
OT/EHR18-60	Emergency Heat Relay Kit	X	X	X	X	X	X	X
TX2N4 ³	TXV Kit	X						
TX2N4A ³	TXV Kit	X	X					
TX3N4 ³	TXV Kit			X	X			
TX5N4 ³	TXV Kit					X	X	X

^{*} Contains 20 brackets; four brackets needed to anchor unit to pad

¹ Installed on indoor coil

² Required for heat pump applications where ambient temperatures fall below 0 °F with 50% or higher relative humidity.

³ Condensing units and heat pumps with reciprocating compressors require the use of start-assist components when used in conjunction with an indoor coil using a non-bleed thermal expansion valve refrigerant metering device. The TXV should always be sized based on the tonnage of the outdoor unit.

