

Heating & Air Conditioning
Amana[®]
LASTS AND LASTS AND LASTS.[®]

ASXC18
SPLIT SYSTEM AIR CONDITIONER
UP TO 18 SEER



COOLING CAPACITY: 34,000 - 56,000 BTU/H

Standard Features

- R-410A chlorine-free refrigerant
- Two-Stage Copeland[®] UltraTech scroll compressor
- High-density foam compressor sound blanket
- ComfortNet[™] Communications System compatible
- Expanded ComfortAlert diagnostics built in
- Set-up capable with two low-voltage wires to outdoor unit
- Diagnostic indicator lights and storage of six fault codes
- Color-coded terminal strip for non-communicating set-up
- High- and low-pressure switches
- Fully charged for 15' of tubing length
- Factory-installed filter dryer
- Coil and ambient temperature sensors
- Two-speed quiet condenser fan motor
- Sweat connection service valves with easy access to gauge ports
- AHRI Certified; ETL Listed

Cabinet Features

- Amana brand sound control top design
- Wire fan discharge grille
- Steel louver coil guard
- Baked-on powder-paint finish
- Rust-resistant coated screws
- Compact footprint
- Top and side maintenance access
- Single-panel access to controls with space provided for field-installed accessories
- When properly anchored, meets the 2001 Florida Building Code unit integrity requirements for hurricane-type winds (Anchor bracket kits available.)



Contents

Nomenclature	2
Product Specifications	3
Expanded Cooling Data	4
AHRI Ratings.....	16
Dimensions	25
Wiring Diagram.....	26
Accessories	27



* Complete warranty details available from your local dealer or at www.amana-hac.com. To receive the Lifetime Unit Replacement Limited Warranty (good for as long as you own your home) and 10-Year Parts Limited Warranty, online registration must be completed within 60 days of installation. Online registration is not required in California or Quebec.

NOMENCLATURE

	A	S	X	C	18	036	1	A	A
	1	2	3	4	5,6	7,8,9	10	11	12
Brand	A Amana® Brand							Engineering * Minor Revision	
Product Category	S Split System							Engineering * Major Revision	
Unit Type	C Condenser R-22 X Condenser R-410A H Heat Pump R-22 Z Heat Pump R-410A							Electrical 1 208/230 V, 1 Phase, 60 Hz 2 220/240 V, 1 Phase, 50 Hz 3 208/230 V, 3 Phase, 60 Hz 4 460 V, 3 Phase, 60 Hz 5 380/415 V, 3 Phase, 50 Hz	
Communication Feature	C ComfortNet 4-wire communications ready							Nominal Capacity 018 1½ Tons 048 4 Tons 024 2 Tons 060 5 Tons 030 2½ Tons 090 7½ tons 036 3 Tons 120 10 Tons 042 3½ Tons	
Efficiency	13 13 SEER 16 16 SEER 14 14 SEER 18 18 SEER								

* Neither used for order entry or inventory management.



Important EnergyStar Notice: EnergyStar ratings are dependent upon conditions beyond equipment installation. Proper sizing and installation of equipment is critical to achieve optimal performance. Split system air conditioners and heat pumps must be matched with appropriate coil components to meet EnergyStar criteria. Ask your contractor for details or visit www.energystar.gov.

SPECIFICATIONS

	ASXC18 0361A	ASXC18 0481A	ASXC18 0601A
Cooling Capacity			
Nominal Cooling (BTU/h)	35,000	47,000	57,000
Decibels	71	72	74
Compressor			
RLA	16.7	21.2	25.6
LRA	82	96	118
Condenser Fan Motor			
Horsepower (RPM)	1/3	1/3	1/3
FLA	2.80	2.80	2.80
Refrigeration System			
Refrigerant Line Size ¹			
Liquid Line Size ("O.D.)	3/8"	3/8"	3/8"
Suction Line Size ("O.D.)	7/8"	1 1/8"	1 1/8"
Refrigerant Connection Size			
Liquid Valve Size ("O.D.)	3/8"	3/8"	3/8"
Suction Valve Size ("O.D.)	7/8"	7/8"	7/8"
Valve Connection Type	Sweat	Sweat	Sweat
Refrigerant Charge	187	262	262
Expansion Device	TXV	TXV	TXV
Superheat at Service Valve	7-9°F	7-9°F	7-9°F
Subcooling at Service Valve	5-7°F	5-7°F	5-7°F
Electrical Data			
Voltage-Phase-Hz	208/230-1-60	208/230-1-60	208/230-1-60
Minimum Circuit Ampacity ¹	23.7	29.3	34.8
Max. Overcurrent Protection ²	40	50	60
Min / Max Volts	197 / 253	197 / 253	197 / 253
Electrical Conduit Size	1/2" or 3/4"	1/2" or 3/4"	1/2" or 3/4"
Ship Weight (lbs)	270	320	330

¹ Wire size should be determined in accordance with National Electrical Codes; extensive wire runs will require larger wire sizes

² Must use time-delay fuses or HACR-type circuit breakers of the same size as noted.

NOTES

- Always check the S&R plate for electrical data on the unit being installed.
- Installer will need to supply 7/8" to 1 1/8" adapters for suction line connections.
- Unit is charged with refrigerant for 15' of 3/8" liquid line. System charge must be adjusted per Installation Instructions Final Charge Procedure.
- Installation of these units that require a TXV Kit to be installed on the indoor coil.
- PLEASE NOTE: the specified TXV is determined by the outdoor unit, not the indoor coil.

EXPANDED COOLING DATA — ASXC180361A* / CA*F4961*6**+TXV / MBVC2000*-1 Low Stage

IDB	AIRFLOW	OUTDOOR AMBIENT TEMPERATURE																									
		65°F				75°F				85°F				95°F				105°F				115°F					
		59	63	67	71	59	63	67	71	59	63	67	71	59	63	67	71	59	63	67	71	59	63	67	71		
70	930	MBh	25.3	26.2	28.8	-	24.7	25.6	28.1	-	24.1	25.0	27.4	-	23.6	24.4	26.8	-	22.4	23.2	25.4	-	20.7	21.5	23.5	-	
		S/T	0.76	0.63	0.44	-	0.79	0.66	0.45	-	0.81	0.67	0.47	-	0.83	0.70	0.48	-	0.86	0.72	0.50	-	0.87	0.73	0.50	-	
	825	ΔT	19	16	12	-	19	17	13	-	19	17	13	-	19	17	13	-	19	17	13	-	18	15	12	-	
		kW	1.30	1.33	1.38	-	1.41	1.45	1.50	-	1.51	1.55	1.60	-	1.60	1.63	1.69	-	1.67	1.71	1.77	-	1.73	1.77	1.84	-	
	720	Amps	5.3	5.5	5.7	-	5.8	5.9	6.1	-	6.3	6.5	6.7	-	6.7	6.9	7.1	-	7.2	7.4	7.6	-	7.6	7.8	8.1	-	
		Hi PR	210	226	229	-	237	255	259	-	270	290	295	-	308	331	335	-	332	357	362	-	394	423	429	-	
	75	930	Lo PR	124	128	140	-	128	132	144	-	132	136	149	-	135	140	153	-	138	143	156	-	142	146	159	-
			MBh	24.6	25.5	27.9	-	24.0	24.9	27.3	-	23.4	24.3	26.6	-	22.9	23.7	26.0	-	21.7	22.5	24.7	-	20.1	20.9	22.9	-
		825	S/T	0.72	0.60	0.42	-	0.75	0.63	0.43	-	0.77	0.64	0.44	-	0.79	0.66	0.46	-	0.82	0.69	0.48	-	0.83	0.69	0.48	-
			ΔT	20	17	13	-	20	17	13	-	20	17	13	-	20	18	13	-	20	17	13	-	20	16	12	-
		720	kW	1.29	1.32	1.37	-	1.40	1.43	1.48	-	1.50	1.53	1.59	-	1.58	1.62	1.68	-	1.65	1.69	1.75	-	1.72	1.76	1.82	-
			Amps	5.3	5.4	5.6	-	5.7	5.9	6.1	-	6.2	6.4	6.6	-	6.7	6.8	7.1	-	7.1	7.3	7.5	-	7.6	7.7	8.0	-
70		930	Hi PR	208	224	227	-	235	253	256	-	267	288	292	-	305	327	332	-	329	354	359	-	390	419	425	-
			Lo PR	123	127	138	-	126	130	142	-	131	135	147	-	134	138	151	-	137	141	154	-	140	145	158	-
		825	MBh	22.7	23.5	25.8	-	22.2	23.0	25.2	-	21.6	22.4	24.6	-	21.1	21.9	24.0	-	20.1	20.8	22.8	-	18.6	19.3	21.1	-
			S/T	0.70	0.58	0.40	-	0.72	0.60	0.42	-	0.74	0.62	0.43	-	0.77	0.64	0.44	-	0.79	0.66	0.46	-	0.80	0.67	0.46	-
		720	ΔT	20	18	13	-	20	18	13	-	20	18	13	-	21	18	14	-	20	18	13	-	19	16	12	-
			kW	1.28	1.31	1.36	-	1.39	1.42	1.47	-	1.48	1.52	1.57	-	1.57	1.60	1.66	-	1.64	1.68	1.74	-	1.70	1.74	1.80	-
	75	930	Amps	5.2	5.4	5.5	-	5.7	5.8	6.0	-	6.2	6.3	6.5	-	6.6	6.8	7.0	-	7.1	7.2	7.5	-	7.5	7.7	7.9	-
			Hi PR	206	221	225	-	233	250	254	-	265	285	289	-	302	324	329	-	326	350	355	-	386	415	421	-
		825	Lo PR	122	125	137	-	125	129	141	-	129	133	146	-	133	137	150	-	135	140	153	-	139	143	156	-
			MBh	25.8	26.5	28.7	30.8	25.2	25.9	28.0	30.1	24.6	25.3	27.4	29.4	24.0	24.7	26.7	28.7	22.8	23.4	25.4	27.2	21.1	21.7	23.5	25.2
		720	S/T	0.86	0.77	0.58	0.38	0.89	0.80	0.60	0.39	0.92	0.82	0.62	0.40	0.95	0.85	0.64	0.41	0.98	0.88	0.66	0.43	0.99	0.89	0.67	0.43
			ΔT	22	20	17	11	22	20	17	12	22	20	17	12	22	21	17	12	22	20	17	12	21	19	16	11
75		930	kW	1.30	1.33	1.38	1.43	1.41	1.45	1.50	1.55	1.51	1.55	1.60	1.66	1.60	1.63	1.69	1.75	1.67	1.71	1.77	1.83	1.73	1.77	1.84	1.90
			Amps	5.3	5.5	5.7	5.9	5.8	5.9	6.1	6.4	6.3	6.5	6.7	6.9	6.7	6.9	7.1	7.4	7.2	7.4	7.6	7.9	7.6	7.8	8.1	8.4
		825	Hi PR	210	226	229	234	237	255	259	265	270	290	295	301	308	331	335	343	332	357	362	370	394	423	429	439
			Lo PR	124	128	140	149	128	132	144	153	132	136	149	158	135	140	153	162	138	143	156	166	142	146	159	170
		720	MBh	25.0	25.7	27.9	29.9	24.4	25.1	27.2	29.2	23.8	24.5	26.6	28.5	23.3	23.9	25.9	27.8	22.1	22.8	24.6	26.4	20.5	21.1	22.8	24.5
			S/T	0.82	0.74	0.56	0.36	0.85	0.76	0.58	0.37	0.87	0.78	0.59	0.38	0.90	0.81	0.61	0.39	0.94	0.84	0.63	0.41	0.94	0.84	0.64	0.41
	75	930	ΔT	23	21	17	12	23	21	17	12	23	21	18	12	23	22	18	12	23	21	17	12	22	20	16	11
			kW	1.29	1.32	1.37	1.42	1.40	1.43	1.48	1.54	1.50	1.53	1.59	1.64	1.58	1.62	1.68	1.74	1.65	1.69	1.75	1.82	1.72	1.76	1.82	1.88
		825	Amps	5.3	5.4	5.6	5.8	5.7	5.9	6.1	6.3	6.2	6.4	6.6	6.9	6.7	6.8	7.1	7.4	7.1	7.3	7.5	7.8	7.6	7.7	8.0	8.3
			Hi PR	208	224	227	232	235	253	256	262	267	288	292	298	305	327	332	339	329	354	359	367	390	419	425	435
		720	Lo PR	123	127	138	147	126	130	142	152	131	135	147	157	134	138	151	161	137	141	154	164	140	145	158	168
			MBh	23.1	23.8	25.7	27.6	22.5	23.2	25.1	27.0	22.0	22.7	24.5	26.3	21.5	22.1	23.9	25.7	20.4	21.0	22.7	24.4	18.9	19.5	21.1	22.6
75		930	S/T	0.79	0.71	0.54	0.35	0.82	0.74	0.56	0.36	0.84	0.75	0.57	0.37	0.87	0.78	0.59	0.38	0.90	0.81	0.61	0.39	0.91	0.81	0.62	0.40
			ΔT	23	22	18	12	24	22	18	12	24	22	18	12	24	22	18	12	24	22	18	12	22	20	17	11
		825	kW	1.28	1.31	1.36	1.40	1.39	1.42	1.47	1.52	1.48	1.52	1.57	1.63	1.57	1.60	1.66	1.72	1.64	1.68	1.74	1.80	1.70	1.74	1.80	1.87
			Amps	5.2	5.4	5.5	5.8	5.7	5.8	6.0	6.2	6.2	6.3	6.5	6.8	6.6	6.8	7.0	7.3	7.1	7.2	7.5	7.8	7.5	7.7	7.9	8.2
		720	Hi PR	206	221	225	230	233	250	254	259	265	285	289	295	302	324	329	336	326	350	355	363	386	415	421	430
			Lo PR	122	125	137	146	125	129	141	150	129	133	146	155	133	137	150	159	135	140	153	162	139	143	156	166

IDB = Entering Indoor Dry Bulb Temperature
 High and low pressures are measured at the liquid and suction service valves.
 Shaded area is ACCA (TVA) conditions
 kW = Total system power
 Amps = outdoor unit amps (comp. + fan)

EXPANDED COOLING DATA — ASXC180361A* / CA*F4961*6**+TXV / MBVC2000*-1 LOW STAGE (CONT.)

IDB	AIRFLOW	OUTDOOR AMBIENT TEMPERATURE												ENTERING INDOOR WET BULB TEMPERATURE											
		65°F				75°F				85°F				95°F				105°F				115°F			
		59	63	67	71	59	63	67	71	59	63	67	71	59	63	67	71	59	63	67	71	59	63	67	71
80	MBh	26.2	26.8	28.6	30.6	25.6	26.2	28.0	29.9	25.0	25.5	27.3	29.2	24.4	24.9	26.6	28.5	23.2	23.7	25.3	27.0	21.5	21.9	23.4	25.0
	S/T	0.95	0.89	0.72	0.54	1.00	0.92	0.75	0.56	1.00	0.94	0.77	0.57	1.00	1.00	0.79	0.59	1.00	1.00	0.82	0.61	1.00	1.00	0.83	0.62
	ΔT	25	23	20	16	25	24	21	17	25	24	21	17	24	25	21	17	23	23	21	16	21	22	19	15
	kW	1.30	1.33	1.38	1.43	1.41	1.45	1.50	1.55	1.51	1.55	1.60	1.66	1.60	1.63	1.69	1.75	1.67	1.71	1.77	1.83	1.73	1.77	1.84	1.90
	Amps	5.3	5.5	5.7	5.9	5.8	5.9	6.1	6.4	6.3	6.5	6.7	6.9	6.7	6.9	7.1	7.4	7.2	7.4	7.6	7.9	7.6	7.8	8.1	8.4
	HI PR	210	226	229	234	237	255	259	265	270	290	295	301	308	331	335	343	332	357	362	370	394	423	429	439
	Lo PR	124	128	140	149	128	132	144	153	132	136	149	158	135	140	153	162	138	143	156	166	142	146	159	170
	MBh	25.4	26.0	27.8	29.7	24.9	25.4	27.1	29.0	24.3	24.8	26.5	28.3	23.7	24.2	25.8	27.6	22.5	23.0	24.6	26.2	20.8	21.3	22.7	24.3
	S/T	0.90	0.85	0.69	0.51	0.93	0.88	0.71	0.53	0.96	0.90	0.73	0.55	0.99	0.93	0.76	0.56	1.00	0.96	0.78	0.59	1.00	0.97	0.79	0.59
	ΔT	26	25	21	17	26	25	22	17	26	25	22	17	26	25	22	17	25	25	21	17	23	23	20	16
kW	1.29	1.32	1.37	1.42	1.40	1.43	1.48	1.54	1.50	1.53	1.59	1.64	1.58	1.62	1.68	1.74	1.65	1.69	1.75	1.82	1.72	1.76	1.82	1.88	
Amps	5.3	5.4	5.6	5.8	5.7	5.9	6.1	6.3	6.2	6.4	6.6	6.9	6.7	6.8	7.1	7.4	7.1	7.3	7.5	7.8	7.6	7.7	8.0	8.3	
HI PR	208	224	227	232	235	253	256	262	267	288	292	298	305	327	332	339	329	354	359	367	390	419	425	435	
Lo PR	123	127	138	147	126	130	142	152	131	135	147	157	134	138	151	161	137	141	154	164	140	145	158	168	
MBh	23.5	24.0	25.6	27.4	22.9	23.4	25.0	26.8	22.4	22.9	24.5	26.1	21.9	22.3	23.9	25.5	20.8	21.2	22.7	24.2	19.2	19.6	21.0	22.4	
S/T	0.87	0.82	0.66	0.50	0.90	0.85	0.69	0.51	0.92	0.87	0.71	0.53	0.95	0.89	0.73	0.54	0.99	0.93	0.76	0.56	1.00	0.94	0.76	0.57	
ΔT	26	25	22	17	26	25	22	18	26	25	22	18	27	26	22	18	26	26	22	17	25	24	20	16	
kW	1.28	1.31	1.36	1.40	1.39	1.42	1.47	1.52	1.48	1.52	1.57	1.63	1.57	1.60	1.66	1.72	1.64	1.68	1.74	1.80	1.70	1.74	1.80	1.87	
Amps	5.2	5.4	5.5	5.8	5.7	5.8	6.0	6.2	6.2	6.3	6.5	6.8	6.6	6.8	7.0	7.3	7.1	7.2	7.5	7.8	7.5	7.7	7.9	8.2	
HI PR	206	221	225	230	233	250	254	259	265	285	289	295	302	324	329	336	326	350	355	363	386	415	421	430	
Lo PR	122	125	137	146	125	129	141	150	129	133	146	155	133	137	150	159	135	140	153	162	139	143	156	166	

85	MBh	26.7	27.2	28.5	30.4	26.0	26.6	27.8	29.7	25.4	25.9	27.1	29.0	24.8	25.3	26.5	28.3	23.6	24.0	25.2	26.8	21.8	22.3	23.3	24.9
	S/T	0.99	0.96	0.86	0.70	1.00	0.99	0.89	0.73	1.00	1.00	0.92	0.74	1.00	1.00	0.95	0.77	1.00	1.00	0.98	0.80	1.00	1.00	0.99	0.80
	ΔT	26	26	24	21	26	26	25	21	25	26	25	21	25	25	25	21	23	24	24	21	22	22	23	20
	kW	1.30	1.33	1.38	1.43	1.41	1.45	1.50	1.55	1.51	1.55	1.60	1.66	1.60	1.63	1.69	1.75	1.67	1.71	1.77	1.83	1.73	1.77	1.84	1.90
	Amps	5.3	5.5	5.7	5.9	5.8	5.9	6.1	6.4	6.3	6.5	6.7	6.9	6.7	6.9	7.1	7.4	7.2	7.4	7.6	7.9	7.6	7.8	8.1	8.4
	HI PR	210	226	229	234	237	255	259	265	270	290	295	301	308	331	335	343	332	357	362	370	394	423	429	439
	Lo PR	124	128	140	149	128	132	144	153	132	136	149	158	135	140	153	162	138	143	156	166	142	146	159	170
	MBh	25.9	26.4	27.6	29.5	25.3	25.8	27.0	28.8	24.7	25.2	26.4	28.1	24.1	24.6	25.7	27.4	22.9	23.3	24.4	26.1	21.2	21.6	22.6	24.1
	S/T	0.95	0.91	0.82	0.67	0.98	0.95	0.85	0.69	1.00	0.97	0.88	0.71	1.00	1.00	0.90	0.73	1.00	1.00	0.94	0.76	1.00	1.00	0.95	0.77
	ΔT	27	27	25	22	28	27	26	22	28	27	26	22	27	27	26	22	25	26	26	22	24	24	24	21
kW	1.29	1.32	1.37	1.42	1.40	1.43	1.48	1.54	1.50	1.53	1.59	1.64	1.58	1.62	1.68	1.74	1.65	1.69	1.75	1.82	1.72	1.76	1.82	1.88	
Amps	5.3	5.4	5.6	5.8	5.7	5.9	6.1	6.3	6.2	6.4	6.6	6.9	6.7	6.8	7.1	7.4	7.1	7.3	7.5	7.8	7.6	7.7	8.0	8.3	
HI PR	208	224	227	232	235	253	256	262	267	288	292	298	305	327	332	339	329	354	359	367	390	419	425	435	
Lo PR	123	127	138	147	126	130	142	152	131	135	147	157	134	138	151	161	137	141	154	164	140	145	158	168	
MBh	23.9	24.4	25.5	27.2	23.3	23.8	24.9	26.6	22.8	23.2	24.3	26.0	22.2	22.7	23.7	25.3	21.1	21.5	22.5	24.1	19.6	19.9	20.9	22.3	
S/T	0.91	0.88	0.79	0.64	0.94	0.91	0.82	0.67	0.97	0.93	0.84	0.68	1.00	0.97	0.87	0.71	1.00	1.00	0.90	0.73	1.00	1.00	0.91	0.74	
ΔT	27.8	27	26	22	28	28	26	23	28	28	26	23	28	28	26	23	27	27	26	23	25	25	24	21	
kW	1.28	1.31	1.36	1.40	1.39	1.42	1.47	1.52	1.48	1.52	1.57	1.63	1.57	1.60	1.66	1.72	1.64	1.68	1.74	1.80	1.70	1.74	1.80	1.87	
Amps	5.2	5.4	5.5	5.8	5.7	5.8	6.0	6.2	6.2	6.3	6.5	6.8	6.6	6.8	7.0	7.3	7.1	7.2	7.5	7.8	7.5	7.7	7.9	8.2	
HI PR	206	221	225	230	233	250	254	259	265	285	289	295	302	324	329	336	326	350	355	363	386	415	421	430	
Lo PR	122	125	137	146	125	129	141	150	129	133	146	155	133	137	150	159	135	140	153	162	139	143	156	166	

IDB = Entering Indoor Dry Bulb Temperature
 High and low pressures are measured at the liquid and suction service valves.
 Shaded area is AHRI (TVA) conditions
 kW = Total system power
 Amps = outdoor unit amps (comp. + fan)

EXPANDED COOLING DATA — ASXC180361A* / CA*F4961*6**+TXV / MBVC2000*-1 HIGH STAGE

IDB	AIRFLOW	OUTDOOR AMBIENT TEMPERATURE																								
		65°F				75°F				85°F				95°F				105°F				115°F				
		59	63	67	71	59	63	67	71	59	63	67	71	59	63	67	71	59	63	67	71	59	63	67	71	
70	1330	MBh	36.7	38.1	41.7	-	35.9	37.2	40.7	-	35.0	36.3	39.8	-	34.2	35.4	38.8	-	32.4	33.6	36.8	-	30.1	31.2	34.1	-
		S/T	0.74	0.62	0.43	-	0.76	0.64	0.44	-	0.78	0.65	0.45	-	0.81	0.68	0.47	-	0.84	0.70	0.49	-	0.85	0.71	0.49	-
	ΔT	19	16	12	-	19	16	12	-	19	16	12	-	19	17	13	-	19	16	12	-	18	15	12	-	
	kW	2.09	2.14	2.21	-	2.26	2.31	2.39	-	2.41	2.47	2.56	-	2.55	2.61	2.70	-	2.66	2.73	2.82	-	2.76	2.83	2.93	-	
	Amps	8.2	8.4	8.7	-	8.9	9.1	9.4	-	9.7	9.9	10.3	-	10.4	10.7	11.0	-	11.1	11.4	11.8	-	11.8	12.1	12.5	-	
	HI PR	220	237	240	-	249	268	271	-	283	304	309	-	322	347	352	-	348	374	380	-	413	444	450	-	
	Lo PR	118	122	133	-	122	126	137	-	126	130	142	-	129	134	146	-	132	136	149	-	135	140	152	-	
	MBh	35.6	36.9	40.5	-	34.8	36.1	39.5	-	34.0	35.2	38.6	-	33.2	34.4	37.7	-	31.5	32.7	35.8	-	29.2	30.2	33.1	-	
	S/T	0.70	0.59	0.41	-	0.73	0.61	0.42	-	0.75	0.62	0.43	-	0.77	0.64	0.45	-	0.80	0.67	0.46	-	0.81	0.67	0.47	-	
	ΔT	20	17	13	-	20	17	13	-	20	17	13	-	20	17	13	-	20	17	13	-	18	16	12	-	
	kW	2.07	2.12	2.19	-	2.24	2.29	2.37	-	2.39	2.45	2.53	-	2.53	2.59	2.68	-	2.64	2.70	2.80	-	2.74	2.80	2.90	-	
	Amps	8.1	8.3	8.6	-	8.8	9.0	9.3	-	9.6	9.9	10.2	-	10.3	10.6	10.9	-	11.0	11.3	11.7	-	11.7	12.0	12.4	-	
HI PR	218	234	238	-	246	265	269	-	280	301	306	-	319	343	348	-	345	371	376	-	409	439	446	-		
Lo PR	117	121	132	-	121	125	136	-	125	129	141	-	128	132	144	-	131	135	147	-	134	138	151	-		
MBh	32.9	34.1	37.4	-	32.1	33.3	36.5	-	31.4	32.5	35.6	-	30.6	31.7	34.8	-	29.1	30.1	33.0	-	26.9	27.9	30.6	-		
S/T	0.68	0.57	0.39	-	0.70	0.59	0.41	-	0.72	0.60	0.42	-	0.74	0.62	0.43	-	0.77	0.65	0.45	-	0.78	0.65	0.45	-		
ΔT	20	17	13	-	20	18	13	-	20	18	13	-	20	18	13	-	20	17	13	-	19	16	12	-		
kW	2.05	2.10	2.17	-	2.22	2.27	2.35	-	2.37	2.43	2.51	-	2.50	2.56	2.65	-	2.62	2.68	2.77	-	2.71	2.78	2.88	-		
Amps	8.1	8.3	8.5	-	8.7	9.0	9.3	-	9.5	9.8	10.1	-	10.2	10.5	10.8	-	10.9	11.2	11.5	-	11.6	11.8	12.3	-		
HI PR	216	232	235	-	244	262	266	-	278	298	303	-	316	340	345	-	341	367	372	-	405	435	441	-		
Lo PR	116	120	131	-	120	123	135	-	124	127	139	-	127	131	143	-	129	134	146	-	133	137	149	-		

75	1330	MBh	37.3	38.4	41.6	44.7	36.5	37.5	40.6	43.6	35.6	36.7	39.7	42.6	34.7	35.8	38.7	41.5	33.0	34.0	36.8	39.5	30.6	31.5	34.1	36.6
		S/T	0.84	0.75	0.57	0.37	0.87	0.78	0.59	0.38	0.89	0.80	0.60	0.39	0.92	0.82	0.62	0.40	0.95	0.85	0.65	0.42	0.96	0.86	0.65	0.42
	ΔT	22	20	16	11	22	20	17	11	22	20	17	11	22	20	17	12	22	20	16	11	22	20	19	15	
	kW	2.09	2.14	2.21	2.28	2.26	2.31	2.39	2.48	2.41	2.47	2.56	2.65	2.55	2.61	2.70	2.80	2.66	2.73	2.82	2.92	2.76	2.83	2.93	3.03	
	Amps	8.2	8.4	8.7	9.0	8.9	9.1	9.4	9.8	9.7	9.9	10.3	10.7	10.4	10.7	11.0	11.5	11.1	11.4	11.8	12.2	11.8	12.1	12.5	13.0	
	HI PR	220	237	240	245	249	268	271	277	283	304	309	316	322	347	352	359	348	374	380	388	413	444	450	460	
	Lo PR	118	122	133	142	122	126	137	146	126	130	142	151	129	134	146	155	132	136	149	158	135	140	152	162	
	MBh	36.3	37.3	40.4	43.4	35.4	36.5	39.5	42.4	34.6	35.6	38.5	41.3	33.7	34.7	37.6	40.3	32.0	33.0	35.7	38.3	29.7	30.6	33.1	35.5	
	S/T	0.80	0.72	0.54	0.35	0.83	0.74	0.56	0.36	0.85	0.76	0.58	0.37	0.88	0.78	0.59	0.38	0.91	0.81	0.62	0.40	0.92	0.82	0.62	0.40	
	ΔT	23	21	17	12	23	21	17	12	23	21	17	12	23	21	17	12	23	21	17	12	21	20	16	11	
	kW	2.07	2.12	2.19	2.26	2.24	2.29	2.37	2.45	2.39	2.45	2.53	2.62	2.53	2.59	2.68	2.77	2.64	2.70	2.80	2.90	2.74	2.80	2.90	3.01	
	Amps	8.1	8.3	8.6	9.0	8.8	9.0	9.3	9.7	9.6	9.9	10.2	10.6	10.3	10.6	10.9	11.4	11.0	11.3	11.7	12.1	11.7	12.0	12.4	12.9	
HI PR	218	234	238	243	246	265	269	275	280	301	306	312	319	343	348	356	345	371	376	384	409	439	446	455		
Lo PR	117	121	132	141	121	125	136	145	125	129	141	150	128	132	144	154	131	135	147	157	134	138	151	161		
MBh	33.5	34.5	37.3	40.0	32.7	33.6	36.4	39.1	31.9	32.8	35.6	38.2	31.1	32.0	34.7	37.2	29.6	30.4	33.0	35.4	27.4	28.2	30.5	32.8		
S/T	0.77	0.69	0.52	0.34	0.80	0.71	0.54	0.35	0.82	0.73	0.55	0.36	0.85	0.76	0.57	0.37	0.88	0.79	0.59	0.38	0.89	0.79	0.60	0.39		
ΔT	23	21	17	12	23	22	18	12	23	22	18	12	24	22	18	12	24	22	18	12	22	20	16	11		
kW	2.05	2.10	2.17	2.24	2.22	2.27	2.35	2.43	2.37	2.43	2.51	2.60	2.50	2.56	2.65	2.75	2.62	2.68	2.77	2.87	2.71	2.78	2.88	2.98		
Amps	8.1	8.3	8.5	8.9	8.7	9.0	9.3	9.6	9.5	9.8	10.1	10.5	10.2	10.5	10.8	11.2	10.9	11.2	11.5	12.0	11.6	11.8	12.3	12.7		
HI PR	216	232	235	241	244	262	266	272	278	298	303	309	316	340	345	352	341	367	372	380	405	435	441	451		
Lo PR	116	120	131	139	120	123	135	143	124	127	139	148	127	131	143	152	129	134	146	155	133	137	149	159		

IDB = Entering Indoor Dry Bulb Temperature
 High and low pressures are measured at the liquid and suction service valves.
 Shaded area is ACCA (TVA) conditions
 kW = Total system power
 Amps = outdoor unit amps (comp. + fan)

EXPANDED COOLING DATA — ASXC180361A* / CA*F4961*6**+TXV / MBVC2000*-1 HIGH STAGE (CONT.)

IDB	AIRFLOW	OUTDOOR AMBIENT TEMPERATURE												ENTERING INDOOR WET BULB TEMPERATURE											
		65°F				75°F				85°F				95°F				105°F				115°F			
		59	63	67	71	59	63	67	71	59	63	67	71	59	63	67	71	59	63	67	71	59	63	67	71
80	MBh	38.0	38.8	41.5	44.4	37.1	37.9	40.5	43.3	36.2	37.0	39.6	42.3	35.4	36.1	38.6	41.3	33.6	34.3	36.7	39.2	31.1	31.8	34.0	36.3
	S/T	0.92	0.86	0.70	0.52	0.95	0.89	0.73	0.54	1.00	0.92	0.75	0.56	1.00	0.95	0.77	0.58	1.00	1.00	0.80	0.60	1.00	1.00	0.81	0.60
	ΔT	24	23	20	16	24	23	20	16	24	24	21	16	24	24	21	16	23	24	20	16	22	22	19	15
	kW	2.09	2.14	2.21	2.28	2.26	2.31	2.39	2.48	2.41	2.47	2.56	2.65	2.55	2.61	2.70	2.80	2.66	2.73	2.82	2.92	2.76	2.83	2.93	3.03
	Amps	8.2	8.4	8.7	9.0	8.9	9.1	9.4	9.8	9.7	9.9	10.3	10.7	10.4	10.7	11.0	11.5	11.1	11.4	11.8	12.2	11.8	12.1	12.5	13.0
	Hi PR	220	237	240	245	249	268	271	277	283	304	309	316	322	347	352	359	348	374	380	388	413	444	450	460
	Lo PR	118	122	133	142	122	126	137	146	126	130	142	151	129	134	146	155	132	136	149	158	135	140	152	162
	MBh	36.9	37.7	40.3	43.1	36.0	36.8	39.3	42.1	35.2	35.9	38.4	41.1	34.3	35.1	37.5	40.1	32.6	33.3	35.6	38.1	30.2	30.9	33.0	35.2
	S/T	0.88	0.82	0.67	0.50	0.91	0.85	0.69	0.52	0.93	0.87	0.71	0.53	0.96	0.90	0.73	0.55	1.00	0.94	0.76	0.57	1.00	0.94	0.77	0.57
	ΔT	25	24	21	17	26	25	21	17	26	25	21	17	26	25	22	17	25	24	21	17	24	23	20	16
kW	2.07	2.12	2.19	2.26	2.24	2.29	2.37	2.45	2.39	2.45	2.53	2.62	2.53	2.59	2.68	2.77	2.64	2.70	2.80	2.90	2.74	2.80	2.90	3.01	
Amps	8.1	8.3	8.6	9.0	8.8	9.0	9.3	9.7	9.6	9.9	10.2	10.6	10.3	10.6	10.9	11.4	11.0	11.3	11.7	12.1	11.7	12.0	12.4	12.9	
Hi PR	218	234	238	243	246	265	269	275	280	301	306	312	319	343	348	356	345	371	376	384	409	439	446	455	
Lo PR	117	121	132	141	121	125	136	145	125	129	141	150	128	132	144	154	131	135	147	157	134	138	151	161	
MBh	34.1	34.8	37.2	39.7	33.3	34.0	36.3	38.8	32.5	33.2	35.4	37.9	31.7	32.4	34.6	37.0	30.1	30.8	32.9	35.1	27.9	28.5	30.4	32.5	
S/T	0.85	0.79	0.65	0.48	0.88	0.82	0.67	0.50	0.90	0.84	0.69	0.51	0.93	0.87	0.71	0.53	0.96	0.90	0.74	0.55	0.97	0.91	0.74	0.55	
ΔT	26	25	22	17	26	25	22	17	26	25	22	17	26	25	22	18	26	25	22	17	24	23	20	16	
kW	2.05	2.10	2.17	2.24	2.22	2.27	2.35	2.43	2.37	2.43	2.51	2.60	2.50	2.56	2.65	2.75	2.62	2.68	2.77	2.87	2.71	2.78	2.88	2.98	
Amps	8.1	8.3	8.5	8.9	8.7	9.0	9.3	9.6	9.5	9.8	10.1	10.5	10.2	10.5	10.8	11.2	10.9	11.2	11.5	12.0	11.6	11.8	12.3	12.7	
Hi PR	216	232	235	241	244	262	266	272	278	298	303	309	316	340	345	352	341	367	372	380	405	435	441	451	
Lo PR	116	120	131	139	120	123	135	143	124	127	139	148	127	131	143	152	129	134	146	155	133	137	149	159	

85	MBh	38.7	39.4	41.3	44.0	37.8	38.5	40.3	43.0	36.9	37.6	39.4	42.0	36.0	36.7	38.4	41.0	34.2	34.8	36.5	38.9	31.7	32.3	33.8	36.1
	S/T	0.96	0.93	0.84	0.68	1.00	0.96	0.87	0.71	1.00	0.99	0.89	0.72	1.00	1.00	0.92	0.75	1.00	1.00	0.96	0.78	1.00	1.00	0.96	0.78
	ΔT	26	25	24	21	26	26	24	21	25	26	24	21	25	25	24	21	24	24	24	21	22	22	23	19
	kW	2.09	2.14	2.21	2.28	2.26	2.31	2.39	2.48	2.41	2.47	2.56	2.65	2.55	2.61	2.70	2.80	2.66	2.73	2.82	2.92	2.76	2.83	2.93	3.03
	Amps	8.2	8.4	8.7	9.0	8.9	9.1	9.4	9.8	9.7	9.9	10.3	10.7	10.4	10.7	11.0	11.5	11.1	11.4	11.8	12.2	11.8	12.1	12.5	13.0
	Hi PR	220	237	240	245	249	268	271	277	283	304	309	316	322	347	352	359	348	374	380	388	413	444	450	460
	Lo PR	118	122	133	142	122	126	137	146	126	130	142	151	129	134	146	155	132	136	149	158	135	140	152	162
	MBh	37.5	38.3	40.1	42.8	36.7	37.4	39.1	41.8	35.8	36.5	38.2	40.8	34.9	35.6	37.3	39.8	33.2	33.8	35.4	37.8	30.7	31.3	32.8	35.0
	S/T	0.92	0.89	0.80	0.65	0.95	0.92	0.83	0.67	0.98	0.94	0.85	0.69	1.00	0.97	0.88	0.71	1.00	1.00	0.91	0.74	1.00	1.00	0.92	0.75
	ΔT	27	27	25	22	27	27	25	22	27	27	25	22	27	27	26	22	26	26	25	22	24	25	24	20
kW	2.07	2.12	2.19	2.26	2.24	2.29	2.37	2.45	2.39	2.45	2.53	2.62	2.53	2.59	2.68	2.77	2.64	2.70	2.80	2.90	2.74	2.80	2.90	3.01	
Amps	8.1	8.3	8.6	9.0	8.8	9.0	9.3	9.7	9.6	9.9	10.2	10.6	10.3	10.6	10.9	11.4	11.0	11.3	11.7	12.1	11.7	12.0	12.4	12.9	
Hi PR	218	234	238	243	246	265	269	275	280	301	306	312	319	343	348	356	345	371	376	384	409	439	446	455	
Lo PR	117	121	132	141	121	125	136	145	125	129	141	150	128	132	144	154	131	135	147	157	134	138	151	161	
MBh	34.6	35.3	37.0	39.5	33.8	34.5	36.1	38.5	33.0	33.7	35.3	37.6	32.2	32.9	34.4	36.7	30.6	31.2	32.7	34.9	28.4	28.9	30.3	32.3	
S/T	0.89	0.86	0.77	0.63	0.92	0.89	0.80	0.65	0.94	0.91	0.82	0.67	0.97	0.94	0.85	0.69	1.00	0.97	0.88	0.71	1.00	0.98	0.89	0.72	
ΔT	28	27	26	22	28	27	26	22	28	27	26	22	28	28	26	23	27	27	26	22	25	25	24	21	
kW	2.05	2.10	2.17	2.24	2.22	2.27	2.35	2.43	2.37	2.43	2.51	2.60	2.50	2.56	2.65	2.75	2.62	2.68	2.77	2.87	2.71	2.78	2.88	2.98	
Amps	8.1	8.3	8.5	8.9	8.7	9.0	9.3	9.6	9.5	9.8	10.1	10.5	10.2	10.5	10.8	11.2	10.9	11.2	11.5	12.0	11.6	11.8	12.3	12.7	
Hi PR	216	232	235	241	244	262	266	272	278	298	303	309	316	340	345	352	341	367	372	380	405	435	441	451	
Lo PR	116	120	131	139	120	123	135	143	124	127	139	148	127	131	143	152	129	134	146	155	133	137	149	159	

IDB = Entering Indoor Dry Bulb Temperature
 High and low pressures are measured at the liquid and suction service valves.
 Shaded area is AHRI (TVA) conditions
 kW = Total system power
 Amps = outdoor unit amps (comp. + fan)

EXPANDED COOLING DATA — ASXC180481A* / CA*F4961*6***+TXV / MBVC2000** -1 Low Stage

IDB	AIRFLOW	OUTDOOR AMBIENT TEMPERATURE																							
		65°F				75°F				85°F				95°F				105°F				115°F			
		59	63	67	71	59	63	67	71	59	63	67	71	59	63	67	71	59	63	67	71	59	63	67	71
70	MBh	34.6	35.8	39.3	-	33.8	35.0	38.3	-	33.0	34.2	37.4	-	32.2	33.3	36.5	-	30.5	31.7	34.7	-	28.3	29.3	32.1	-
	S/T	0.76	0.64	0.44	-	0.79	0.66	0.46	-	0.81	0.68	0.47	-	0.83	0.70	0.48	-	0.87	0.72	0.50	-	0.87	0.73	0.51	-
	ΔT	18	16	12	-	18	16	12	-	18	16	12	-	19	16	12	-	18	16	12	-	17	15	11	-
	kW	1.87	1.91	1.97	-	2.02	2.07	2.14	-	2.16	2.21	2.29	-	2.28	2.34	2.42	-	2.39	2.44	2.53	-	2.47	2.53	2.62	-
	Amps	7.2	7.4	7.6	-	7.8	8.0	8.3	-	8.5	8.7	9.0	-	9.1	9.4	9.7	-	9.7	10.0	10.3	-	10.4	10.6	11.0	-
	Hi PR	216	232	235	-	244	262	266	-	277	298	303	-	316	340	345	-	356	382	388	-	398	428	434	-
	Lo PR	121	125	137	-	125	129	141	-	129	133	146	-	133	137	149	-	135	140	152	-	139	143	156	-
	MBh	33.6	34.8	38.1	-	32.8	34.0	37.2	-	32.0	33.2	36.3	-	31.2	32.4	35.5	-	29.7	30.7	33.7	-	27.5	28.5	31.2	-
	S/T	0.73	0.61	0.42	-	0.75	0.63	0.44	-	0.77	0.64	0.45	-	0.80	0.66	0.46	-	0.83	0.69	0.48	-	0.83	0.70	0.48	-
	ΔT	19	16	13	-	19	17	13	-	19	17	13	-	19	17	13	-	19	17	13	-	18	16	12	-
	kW	1.85	1.89	1.96	-	2.00	2.05	2.12	-	2.14	2.19	2.27	-	2.26	2.32	2.40	-	2.36	2.42	2.51	-	2.45	2.51	2.60	-
	Amps	7.1	7.3	7.6	-	7.7	7.9	8.2	-	8.4	8.7	9.0	-	9.0	9.3	9.6	-	9.7	9.9	10.2	-	10.3	10.5	10.9	-
Hi PR	214	230	233	-	242	260	263	-	275	295	300	-	313	336	341	-	352	378	384	-	394	424	430	-	
Lo PR	120	124	135	-	124	128	139	-	128	132	144	-	131	136	148	-	134	138	151	-	137	142	155	-	
MBh	31.0	32.1	35.2	-	30.3	31.4	34.4	-	29.5	30.6	33.5	-	28.8	29.9	32.7	-	27.4	28.4	31.1	-	25.4	26.3	28.8	-	
S/T	0.70	0.58	0.40	-	0.73	0.61	0.42	-	0.74	0.62	0.43	-	0.77	0.64	0.44	-	0.80	0.67	0.46	-	0.80	0.67	0.46	-	
ΔT	19	17	13	-	20	17	13	-	20	17	13	-	20	17	13	-	20	17	13	-	18	16	12	-	
kW	1.83	1.88	1.94	-	1.99	2.03	2.10	-	2.12	2.17	2.25	-	2.24	2.29	2.38	-	2.34	2.40	2.48	-	2.43	2.49	2.58	-	
Amps	7.1	7.2	7.5	-	7.7	7.9	8.1	-	8.4	8.6	8.9	-	9.0	9.2	9.5	-	9.6	9.8	10.1	-	10.2	10.4	10.8	-	
Hi PR	212	227	231	-	239	257	261	-	272	292	297	-	310	333	338	-	348	375	380	-	390	420	426	-	
Lo PR	119	123	134	-	123	126	138	-	127	131	143	-	130	134	147	-	133	137	149	-	136	140	153	-	

75	MBh	35.2	36.2	39.2	42.0	34.3	35.4	38.3	41.1	33.5	34.5	37.4	40.1	32.7	33.7	36.4	39.1	31.1	32.0	34.6	37.2	28.8	29.6	32.1	34.4
	S/T	0.86	0.77	0.59	0.38	0.90	0.80	0.61	0.39	0.92	0.82	0.62	0.40	0.95	0.85	0.64	0.41	0.98	0.88	0.67	0.43	0.99	0.89	0.67	0.43
	ΔT	21	19	16	11	21	20	16	11	21	20	16	11	22	20	16	11	22	20	16	11	20	18	15	10
	kW	1.87	1.91	1.97	2.04	2.02	2.07	2.14	2.22	2.16	2.21	2.29	2.37	2.28	2.34	2.42	2.51	2.39	2.44	2.53	2.62	2.47	2.53	2.62	2.72
	Amps	7.2	7.4	7.6	7.9	7.8	8.0	8.3	8.6	8.5	8.7	9.0	9.4	9.1	9.4	9.7	10.1	9.7	10.0	10.3	10.8	10.4	10.6	11.0	11.4
	Hi PR	216	232	235	241	244	262	266	272	277	298	303	309	316	340	345	352	356	382	388	396	398	428	434	444
	Lo PR	121	125	137	146	125	129	141	150	129	133	146	155	133	137	149	159	135	140	152	162	139	143	156	166
	MBh	34.1	35.1	38.0	40.8	33.3	34.3	37.2	39.9	32.5	33.5	36.3	38.9	31.7	32.7	35.4	38.0	30.2	31.1	33.6	36.1	27.9	28.8	31.1	33.4
	S/T	0.82	0.74	0.56	0.36	0.85	0.76	0.58	0.37	0.88	0.78	0.59	0.38	0.90	0.81	0.61	0.39	0.94	0.84	0.64	0.41	0.95	0.85	0.64	0.41
	ΔT	22	20	17	11	22	21	17	12	22	21	17	12	22	21	17	12	22	20	17	12	21	19	16	11
	kW	1.85	1.89	1.96	2.03	2.00	2.05	2.12	2.20	2.14	2.19	2.27	2.35	2.26	2.32	2.40	2.48	2.36	2.42	2.51	2.60	2.45	2.51	2.60	2.69
	Amps	7.1	7.3	7.6	7.9	7.7	7.9	8.2	8.5	8.4	8.7	9.0	9.3	9.0	9.3	9.6	10.0	9.7	9.9	10.2	10.6	10.3	10.5	10.9	11.3
Hi PR	214	230	233	238	242	260	263	269	275	295	300	306	313	336	341	349	352	378	384	392	394	424	430	439	
Lo PR	120	124	135	144	124	128	139	148	128	132	144	154	131	136	148	158	134	138	151	161	137	142	155	165	
MBh	31.5	32.4	35.1	37.7	30.8	31.7	34.3	36.8	30.0	30.9	33.5	35.9	29.3	30.2	32.7	35.1	27.8	28.7	31.0	33.3	25.8	26.6	28.7	30.8	
S/T	0.80	0.71	0.54	0.35	0.82	0.74	0.56	0.36	0.85	0.76	0.57	0.37	0.87	0.78	0.59	0.38	0.91	0.81	0.61	0.39	0.91	0.82	0.62	0.40	
ΔT	22	21	17	12	23	21	17	12	23	21	17	12	23	21	17	12	23	21	17	12	21	19	16	11	
kW	1.83	1.88	1.94	2.01	1.99	2.03	2.10	2.18	2.12	2.17	2.25	2.33	2.24	2.29	2.38	2.46	2.34	2.40	2.48	2.57	2.43	2.49	2.58	2.67	
Amps	7.1	7.2	7.5	7.8	7.7	7.9	8.1	8.4	8.4	8.6	8.9	9.2	9.0	9.2	9.5	9.9	9.6	9.8	10.1	10.5	10.2	10.4	10.8	11.2	
Hi PR	212	227	231	236	239	257	261	267	272	292	297	303	310	333	338	345	348	375	380	388	390	420	426	435	
Lo PR	119	123	134	143	123	126	138	147	127	131	143	152	130	134	147	156	133	137	149	159	136	140	153	163	

IDB = Entering Indoor Dry Bulb Temperature
 High and low pressures are measured at the liquid and suction service valves.
 Shaded area is ACCA (TVA) conditions
 kW = Total system power
 Amps = outdoor unit amps (comp. + fan)

EXPANDED COOLING DATA — ASXC180481A* / CA*F4961*6** +TXV / MBVC2000** -1 Low Stage (CONT.)

IDB	AIRFLOW	OUTDOOR AMBIENT TEMPERATURE												ENTERING INDOOR WET BULB TEMPERATURE											
		65°F				75°F				85°F				95°F				105°F				115°F			
		59	63	67	71	59	63	67	71	59	63	67	71	59	63	67	71	59	63	67	71	59	63	67	71
80	MIBh	35.8	36.6	39.1	41.8	34.9	35.7	38.2	40.8	34.1	34.9	37.2	39.8	33.3	34.0	36.3	38.8	31.6	32.3	34.5	36.9	29.3	29.9	32.0	34.2
	S/T	0.95	0.89	0.72	0.54	1.00	0.92	0.75	0.56	1.00	0.95	0.77	0.58	1.00	1.00	0.79	0.59	1.00	1.00	0.82	0.62	1.00	1.00	0.83	0.62
	ΔT	24	23	20	16	24	23	20	16	24	23	20	16	23	24	20	16	22	21	18	15	20	21	18	15
	kW	1.87	1.91	1.97	2.04	2.02	2.07	2.14	2.22	2.16	2.21	2.29	2.37	2.28	2.34	2.42	2.51	2.39	2.44	2.53	2.62	2.47	2.53	2.62	2.72
	Amps	7.2	7.4	7.6	7.9	7.8	8.0	8.3	8.6	8.5	8.7	9.0	9.4	9.1	9.4	9.7	10.1	9.7	10.0	10.3	10.8	10.4	10.6	11.0	11.4
	HI PR	216	232	235	241	244	262	266	272	277	298	303	309	316	340	345	352	356	382	388	396	398	428	434	444
	Lo PR	121	125	137	146	125	129	141	150	129	133	146	155	133	137	149	159	135	140	152	162	139	143	156	166
	MIBh	34.7	35.5	37.9	40.5	33.9	34.7	37.0	39.6	33.1	33.8	36.2	38.7	32.3	33.0	35.3	37.7	30.7	31.4	33.5	35.8	28.4	29.1	31.0	33.2
	S/T	0.90	0.85	0.69	0.52	0.94	0.88	0.72	0.53	0.96	0.90	0.73	0.55	0.99	0.93	0.76	0.57	1.00	0.97	0.79	0.59	1.00	0.97	0.79	0.59
	ΔT	25	24	20	16	25	24	21	17	25	24	21	17	25	24	21	17	24	24	21	16	22	22	19	15
kW	1.85	1.89	1.96	2.03	2.00	2.05	2.12	2.20	2.14	2.19	2.27	2.35	2.26	2.32	2.40	2.48	2.36	2.42	2.51	2.60	2.45	2.51	2.60	2.69	
Amps	7.1	7.3	7.6	7.9	7.7	7.9	8.2	8.5	8.4	8.7	9.0	9.3	9.0	9.3	9.6	10.0	9.7	9.9	10.2	10.6	10.3	10.5	10.9	11.3	
HI PR	214	230	233	238	242	260	263	269	275	295	300	306	313	336	341	349	352	378	384	392	394	424	430	439	
Lo PR	120	124	135	144	124	128	139	148	128	132	144	154	131	136	148	158	134	138	151	161	137	142	155	165	
MIBh	32.1	32.8	35.0	37.4	31.3	32.0	34.2	36.5	30.6	31.2	33.4	35.7	29.8	30.5	32.6	34.8	28.3	29.0	30.9	33.1	26.2	26.8	28.7	30.6	
S/T	0.87	0.82	0.67	0.50	0.90	0.85	0.69	0.52	0.93	0.87	0.71	0.53	0.96	0.90	0.73	0.55	0.99	0.93	0.76	0.57	1.00	0.94	0.76	0.57	
ΔT	25	24	21	17	25	24	21	17	25	24	21	17	26	25	21	17	25	24	21	17	24	23	20	16	
kW	1.83	1.88	1.94	2.01	1.99	2.03	2.10	2.18	2.12	2.17	2.25	2.33	2.24	2.29	2.38	2.46	2.34	2.40	2.48	2.57	2.43	2.49	2.58	2.67	
Amps	7.1	7.2	7.5	7.8	7.7	7.9	8.1	8.4	8.4	8.6	8.9	9.2	9.0	9.2	9.5	9.9	9.6	9.8	10.1	10.5	10.2	10.4	10.8	11.2	
HI PR	212	227	231	236	239	257	261	267	272	292	297	303	310	333	338	345	348	375	380	388	390	420	426	435	
Lo PR	119	123	134	143	123	126	138	147	127	131	143	152	130	134	147	156	133	137	149	159	136	140	153	163	

85	MIBh	36.4	37.1	38.9	41.5	35.6	36.2	38.0	40.5	34.7	35.4	37.1	39.5	33.9	34.5	36.2	38.6	32.2	32.8	34.3	36.6	29.8	30.4	31.8	33.9
	S/T	0.99	0.96	0.87	0.70	1.00	0.99	0.90	0.73	1.00	1.00	0.92	0.75	1.00	1.00	0.95	0.77	1.00	1.00	0.99	0.80	1.00	1.00	0.99	0.81
	ΔT	25	25	23	20	25	25	24	20	24	25	24	20	23	24	24	21	22	23	23	20	21	21	22	19
	kW	1.87	1.91	1.97	2.04	2.02	2.07	2.14	2.22	2.16	2.21	2.29	2.37	2.28	2.34	2.42	2.51	2.39	2.44	2.53	2.62	2.47	2.53	2.62	2.72
	Amps	7.2	7.4	7.6	7.9	7.8	8.0	8.3	8.6	8.5	8.7	9.0	9.4	9.1	9.4	9.7	10.1	9.7	10.0	10.3	10.8	10.4	10.6	11.0	11.4
	HI PR	216	232	235	241	244	262	266	272	277	298	303	309	316	340	345	352	356	382	388	396	398	428	434	444
	Lo PR	121	125	137	146	125	129	141	150	129	133	146	155	133	137	149	159	135	140	152	162	139	143	156	166
	MIBh	35.3	36.0	37.7	40.3	34.5	35.2	36.9	39.3	33.7	34.4	36.0	38.4	32.9	33.5	35.1	37.4	31.2	31.8	33.3	35.6	28.9	29.5	30.9	33.0
	S/T	0.95	0.92	0.83	0.67	0.98	0.95	0.86	0.69	1.00	0.97	0.88	0.71	1.00	1.00	0.91	0.74	1.00	1.00	0.94	0.76	1.00	1.00	0.95	0.77
	ΔT	26	26	24	21	27	26	25	21	26	26	25	21	26	26	25	22	24	25	25	21	23	23	23	20
kW	1.85	1.89	1.96	2.03	2.00	2.05	2.12	2.20	2.14	2.19	2.27	2.35	2.26	2.32	2.40	2.48	2.36	2.42	2.51	2.60	2.45	2.51	2.60	2.69	
Amps	7.1	7.3	7.6	7.9	7.7	7.9	8.2	8.5	8.4	8.7	9.0	9.3	9.0	9.3	9.6	10.0	9.7	9.9	10.2	10.6	10.3	10.5	10.9	11.3	
HI PR	214	230	233	238	242	260	263	269	275	295	300	306	313	336	341	349	352	378	384	392	394	424	430	439	
Lo PR	120	124	135	144	124	128	139	148	128	132	144	154	131	136	148	158	134	138	151	161	137	142	155	165	
MIBh	32.6	33.3	34.8	37.2	31.9	32.5	34.0	36.3	31.1	31.7	33.2	35.4	30.3	30.9	32.4	34.6	28.8	29.4	30.8	32.8	26.7	27.2	28.5	30.4	
S/T	0.91	0.88	0.80	0.65	0.95	0.91	0.83	0.67	0.97	0.94	0.85	0.69	1.00	0.97	0.87	0.71	1.00	1.00	0.91	0.74	1.00	1.00	0.91	0.74	
ΔT	26.8	26	25	22	27	27	25	22	27	27	25	22	27	27	25	22	26	26	25	22	24	24	23	20	
kW	1.83	1.88	1.94	2.01	1.99	2.03	2.10	2.18	2.12	2.17	2.25	2.33	2.24	2.29	2.38	2.46	2.34	2.40	2.48	2.57	2.43	2.49	2.58	2.67	
Amps	7.1	7.2	7.5	7.8	7.7	7.9	8.1	8.4	8.4	8.6	8.9	9.2	9.0	9.2	9.5	9.9	9.6	9.8	10.1	10.5	10.2	10.4	10.8	11.2	
HI PR	212	227	231	236	239	257	261	267	272	292	297	303	310	333	338	345	348	375	380	388	390	420	426	435	
Lo PR	119	123	134	143	123	126	138	147	127	131	143	152	130	134	147	156	133	137	149	159	136	140	153	163	

IDB = Entering Indoor Dry Bulb Temperature
 High and low pressures are measured at the liquid and suction service valves.
 Shaded area is AHRI (TVA) conditions
 kW = Total system power
 Amps = outdoor unit amps (comp. + fan)

EXPANDED COOLING DATA — ASXC180481A* / CA*F4961*6***+TXV / MBVC2000** -1 HIGH STAGE

IDB	AIRFLOW	OUTDOOR AMBIENT TEMPERATURE												ENTERING INDOOR WET BULB TEMPERATURE											
		65°F				75°F				85°F				95°F				105°F				115°F			
		59	63	67	71	59	63	67	71	59	63	67	71	59	63	67	71	59	63	67	71	59	63	67	71
70	MBh	48.2	50.0	54.8	-	47.1	48.8	53.5	-	46.0	47.7	52.2	-	44.9	46.5	50.9	-	42.6	44.2	48.4	-	39.5	40.9	44.8	-
	S/T	0.77	0.64	0.44	-	0.79	0.66	0.46	-	0.81	0.68	0.47	-	0.84	0.70	0.49	-	0.87	0.73	0.50	-	0.88	0.73	0.51	-
	ΔT	17	15	11	-	17	15	11	-	17	15	11	-	18	15	12	-	17	15	11	-	16	14	11	-
	kW	2.87	2.94	3.03	-	3.10	3.17	3.27	-	3.30	3.37	3.48	-	3.47	3.55	3.67	-	3.62	3.70	3.83	-	3.75	3.84	3.97	-
	Amps	10.2	10.5	10.8	-	11.1	11.4	11.7	-	12.1	12.4	12.8	-	13.0	13.3	13.7	-	13.8	14.2	14.7	-	14.7	15.1	15.6	-
	Hi PR	228	245	248	-	257	277	280	-	292	315	319	-	333	358	363	-	375	403	409	-	420	451	458	-
	Lo PR	121	124	136	-	124	128	140	-	128	132	145	-	132	136	148	-	134	139	151	-	138	142	155	-
	MBh	46.8	48.5	53.2	-	45.7	47.4	51.9	-	44.6	46.3	50.7	-	43.5	45.1	49.5	-	41.4	42.9	47.0	-	38.3	39.7	43.5	-
	S/T	0.73	0.61	0.42	-	0.76	0.63	0.44	-	0.78	0.65	0.45	-	0.80	0.67	0.46	-	0.83	0.69	0.48	-	0.84	0.70	0.48	-
	ΔT	18	16	12	-	18	16	12	-	18	16	12	-	18	16	12	-	18	16	12	-	17	15	11	-
	kW	2.85	2.91	3.01	-	3.07	3.14	3.24	-	3.27	3.34	3.45	-	3.44	3.52	3.64	-	3.59	3.67	3.80	-	3.72	3.80	3.93	-
	Amps	10.1	10.4	10.7	-	11.0	11.2	11.6	-	12.0	12.3	12.7	-	12.8	13.2	13.6	-	13.7	14.0	14.5	-	14.5	14.9	15.4	-
Hi PR	225	242	246	-	255	274	278	-	290	311	316	-	330	355	360	-	371	399	405	-	416	447	453	-	
Lo PR	119	123	134	-	123	127	138	-	127	131	143	-	130	135	147	-	133	137	150	-	136	141	154	-	
MBh	43.2	44.8	49.1	-	42.2	43.7	47.9	-	41.2	42.7	46.8	-	40.2	41.7	45.6	-	38.2	39.6	43.4	-	35.4	36.7	40.2	-	
S/T	0.70	0.59	0.41	-	0.73	0.61	0.42	-	0.75	0.62	0.43	-	0.77	0.64	0.45	-	0.80	0.67	0.46	-	0.81	0.67	0.47	-	
ΔT	18	16	12	-	19	16	12	-	19	16	12	-	19	16	12	-	18	16	12	-	17	15	11	-	
kW	2.83	2.89	2.98	-	3.05	3.12	3.22	-	3.24	3.32	3.43	-	3.42	3.49	3.61	-	3.56	3.64	3.76	-	3.69	3.77	3.90	-	
Amps	10.0	10.3	10.6	-	10.9	11.1	11.5	-	11.9	12.2	12.6	-	12.7	13.0	13.5	-	13.6	13.9	14.4	-	14.4	14.8	15.3	-	
Hi PR	223	240	243	-	252	271	275	-	287	308	313	-	327	351	356	-	367	395	401	-	411	442	449	-	
Lo PR	118	122	133	-	122	125	137	-	126	130	142	-	129	133	145	-	132	136	148	-	135	139	152	-	

75	MBh	49.0	50.5	54.6	58.7	47.9	49.3	53.4	57.3	46.8	48.1	52.1	55.9	45.6	47.0	50.8	54.6	43.3	44.6	48.3	51.8	40.1	41.3	44.7	48.0
	S/T	0.87	0.78	0.59	0.38	0.90	0.81	0.61	0.39	0.92	0.83	0.63	0.40	0.95	0.85	0.65	0.42	0.99	0.89	0.67	0.43	1.00	0.89	0.68	0.44
	ΔT	20	18	15	10	20	19	15	10	20	19	15	11	20	19	15	11	20	18	15	10	19	17	14	10
	kW	2.87	2.94	3.03	3.13	3.10	3.17	3.27	3.38	3.30	3.37	3.48	3.60	3.47	3.55	3.67	3.80	3.62	3.70	3.83	3.96	3.75	3.84	3.97	4.10
	Amps	10.2	10.5	10.8	11.2	11.1	11.4	11.7	12.2	12.1	12.4	12.8	13.3	13.0	13.3	13.7	14.3	13.8	14.2	14.7	15.3	14.7	15.1	15.6	16.2
	Hi PR	228	245	248	254	257	277	280	287	292	315	319	326	333	358	363	371	375	403	409	418	420	451	458	468
	Lo PR	121	124	136	145	124	128	140	149	128	132	145	154	132	136	148	158	134	139	151	161	138	142	155	165
	MBh	47.6	49.0	53.1	56.9	46.5	47.9	51.8	55.6	45.4	46.7	50.6	54.3	44.3	45.6	49.4	53.0	42.1	43.3	46.9	50.3	39.0	40.1	43.4	46.6
	S/T	0.83	0.74	0.56	0.36	0.86	0.77	0.58	0.37	0.88	0.79	0.60	0.38	0.91	0.81	0.62	0.40	0.94	0.84	0.64	0.41	0.95	0.85	0.64	0.41
	ΔT	21	19	16	11	21	19	16	11	21	19	16	11	21	20	16	11	21	19	16	11	20	18	15	10
	kW	2.85	2.91	3.01	3.10	3.07	3.14	3.24	3.35	3.27	3.34	3.45	3.57	3.44	3.52	3.64	3.76	3.59	3.67	3.80	3.93	3.72	3.80	3.93	4.07
	Amps	10.1	10.4	10.7	11.1	11.0	11.2	11.6	12.1	12.0	12.3	12.7	13.2	12.8	13.2	13.6	14.2	13.7	14.0	14.5	15.1	14.5	14.9	15.4	16.0
Hi PR	225	242	246	251	255	274	278	284	290	311	316	323	330	355	360	368	371	399	405	414	416	447	453	463	
Lo PR	119	123	134	143	123	127	138	147	127	131	143	152	130	135	147	156	133	137	150	160	136	141	154	163	
MBh	43.9	45.2	49.0	52.6	42.9	44.2	47.8	51.3	41.9	43.1	46.7	50.1	40.9	42.1	45.6	48.9	38.8	40.0	43.3	46.4	36.0	37.0	40.1	43.0	
S/T	0.80	0.72	0.54	0.35	0.83	0.74	0.56	0.36	0.85	0.76	0.58	0.37	0.88	0.79	0.59	0.38	0.91	0.81	0.62	0.40	0.92	0.82	0.62	0.40	
ΔT	21	19	16	11	21	20	16	11	21	20	16	11	22	20	16	11	21	20	16	11	20	18	15	10	
kW	2.83	2.89	2.98	3.08	3.05	3.12	3.22	3.32	3.24	3.32	3.43	3.54	3.42	3.49	3.61	3.73	3.56	3.64	3.76	3.89	3.69	3.77	3.90	4.03	
Amps	10.0	10.3	10.6	11.0	10.9	11.1	11.5	12.0	11.9	12.2	12.6	13.1	12.7	13.0	13.5	14.0	13.6	13.9	14.4	15.0	14.4	14.8	15.3	15.9	
Hi PR	223	240	243	249	252	271	275	281	287	308	313	320	327	351	356	364	367	395	401	409	411	442	449	459	
Lo PR	118	122	133	142	122	125	137	146	126	130	142	151	129	133	145	155	132	136	148	158	135	139	152	162	

IDB = Entering Indoor Dry Bulb Temperature
 High and low pressures are measured at the liquid and suction service valves.
 Shaded area is ACCA (TVA) conditions
 kW = Total system power
 Amps = outdoor unit amps (comp. + fan)

EXPANDED COOLING DATA — ASXC180481A* / CA*F4961*6**+TXV / MBVC2000** -1 HIGH STAGE (CONT.)

IDB	AIRFLOW	OUTDOOR AMBIENT TEMPERATURE																									
		65°F				75°F				85°F				95°F				105°F				115°F					
		59	63	67	71	59	63	67	71	59	63	67	71	59	63	67	71	59	63	67	71	59	63	67	71		
80	1970	MBh	49.9	51.0	54.5	58.2	48.7	49.8	53.2	56.9	47.6	48.6	52.0	55.5	46.4	47.4	50.7	54.2	44.1	45.1	48.1	51.5	40.9	41.7	44.6	47.7	
		S/T	0.95	0.89	0.73	0.54	1.00	0.93	0.75	0.56	1.00	0.95	0.77	0.58	1.00	1.00	0.80	0.60	1.00	1.00	0.83	0.62	1.00	1.00	0.84	0.63	
	1750	ΔT	2.2	2.1	1.9	1.5	2.3	2.2	1.9	1.5	2.2	2.2	1.9	1.5	2.2	2.2	1.9	1.5	2.1	2.1	1.9	1.5	1.9	1.9	1.7	1.4	
		kW	2.87	2.94	3.03	3.13	3.10	3.17	3.27	3.38	3.30	3.37	3.48	3.60	3.47	3.55	3.67	3.80	3.62	3.70	3.83	3.96	3.75	3.84	3.97	4.10	
	1530	Amps	10.2	10.5	10.8	11.2	11.1	11.4	11.7	12.2	12.1	12.4	12.8	13.3	13.0	13.3	13.7	14.3	13.8	14.2	14.7	15.3	14.7	15.1	15.6	16.2	
		Hi PR	228	245	248	254	257	277	280	287	292	315	319	326	333	358	363	371	375	403	409	418	420	451	458	468	
	85	1970	Lo PR	121	124	136	145	124	128	140	149	128	132	145	154	132	136	148	158	134	139	151	161	138	142	155	165
			MBh	48.5	49.5	52.9	56.5	47.3	48.4	51.7	55.2	46.2	47.2	50.4	53.9	45.1	46.1	49.2	52.6	42.8	43.8	46.7	50.0	39.7	40.5	43.3	46.3
		1750	S/T	0.91	0.85	0.69	0.52	0.94	0.88	0.72	0.54	0.97	0.91	0.74	0.55	1.00	0.94	0.76	0.57	1.00	0.97	0.79	0.59	1.00	0.98	0.80	0.60
			ΔT	2.3	2.2	1.9	1.5	2.3	2.2	2.0	1.6	2.3	2.2	2.0	1.6	2.4	2.3	2.0	1.6	2.4	2.3	2.0	1.6	2.2	2.1	1.8	1.4
		1530	kW	2.85	2.91	3.01	3.10	3.07	3.14	3.24	3.35	3.27	3.34	3.45	3.57	3.44	3.52	3.64	3.76	3.59	3.67	3.80	3.93	3.72	3.80	3.93	4.07
			Amps	10.1	10.4	10.7	11.1	11.0	11.2	11.6	12.1	12.0	12.3	12.7	13.2	12.8	13.2	13.6	14.2	13.7	14.0	14.5	15.1	14.5	14.9	15.4	16.0
85		1970	Hi PR	225	242	246	251	255	274	278	284	290	311	316	323	330	355	360	368	371	399	405	414	416	447	453	463
			Lo PR	119	123	134	143	123	127	138	147	127	131	143	152	130	135	147	156	133	137	150	160	136	141	154	163
		1750	MBh	44.7	45.7	48.8	52.2	43.7	44.6	47.7	51.0	42.6	43.6	46.6	49.8	41.6	42.5	45.4	48.6	39.5	40.4	43.1	46.1	36.6	37.4	40.0	42.7
			S/T	0.88	0.82	0.67	0.50	0.91	0.85	0.69	0.52	0.93	0.87	0.71	0.53	0.96	0.90	0.73	0.55	1.00	0.94	0.76	0.57	1.01	0.94	0.77	0.57
		1530	ΔT	2.4	2.3	2.0	1.6	2.4	2.3	2.0	1.6	2.4	2.3	2.0	1.6	2.4	2.3	2.0	1.6	2.4	2.3	2.0	1.6	2.2	2.1	1.8	1.5
			kW	2.83	2.89	2.98	3.08	3.05	3.12	3.22	3.32	3.24	3.32	3.43	3.54	3.42	3.49	3.61	3.73	3.56	3.64	3.76	3.89	3.69	3.77	3.90	4.03
	85	1970	Amps	10.0	10.3	10.6	11.0	10.9	11.1	11.5	12.0	11.9	12.2	12.6	13.1	12.7	13.0	13.5	14.0	13.6	13.9	14.4	15.0	14.4	14.8	15.3	15.9
			Hi PR	223	240	243	249	252	271	275	281	287	308	313	320	327	351	356	364	367	395	401	409	411	442	449	459
		1750	Lo PR	118	122	133	142	122	125	137	146	126	130	142	151	129	133	145	155	132	136	148	158	135	139	152	162
			MBh	50.8	51.8	54.2	57.8	49.6	50.6	53.0	56.5	48.4	49.4	51.7	55.1	47.2	48.2	50.4	53.8	44.9	45.7	47.9	51.1	41.6	42.4	44.4	47.3
		1530	S/T	1.00	0.97	0.87	0.71	1.00	1.00	0.90	0.73	1.00	1.00	0.93	0.75	1.00	1.00	0.96	0.78	1.00	1.00	0.99	0.80	1.00	1.00	1.00	0.81
			ΔT	2.4	2.3	2.2	1.9	2.3	2.4	2.2	1.9	2.3	2.3	2.2	1.9	2.2	2.2	2.2	1.9	2.1	2.1	2.2	1.9	1.9	2.0	2.1	1.8
85		1970	kW	2.87	2.94	3.03	3.13	3.10	3.17	3.27	3.38	3.30	3.37	3.48	3.60	3.47	3.55	3.67	3.80	3.62	3.70	3.83	3.96	3.75	3.84	3.97	4.10
			Amps	10.2	10.5	10.8	11.2	11.1	11.4	11.7	12.2	12.1	12.4	12.8	13.3	13.0	13.3	13.7	14.3	13.8	14.2	14.7	15.3	14.7	15.1	15.6	16.2
		1750	Hi PR	228	245	248	254	257	277	280	287	292	315	319	326	333	358	363	371	375	403	409	418	420	451	458	468
			Lo PR	121	124	136	145	124	128	140	149	128	132	145	154	132	136	148	158	134	139	151	161	138	142	155	165
		1530	MBh	49.3	50.3	52.6	56.2	48.2	49.1	51.4	54.8	47.0	47.9	50.2	53.5	45.9	46.7	49.0	52.2	43.6	44.4	46.5	49.6	40.4	41.1	43.1	46.0
			S/T	0.95	0.92	0.83	0.67	0.99	0.95	0.86	0.70	1.00	0.98	0.88	0.72	1.00	1.00	0.91	0.74	1.00	1.00	0.95	0.77	1.00	1.00	0.95	0.77
	85	1970	ΔT	2.5	2.4	2.3	2.0	2.5	2.5	2.3	2.0	2.5	2.5	2.3	2.0	2.4	2.5	2.3	2.0	2.4	2.5	2.3	2.0	2.1	2.2	2.2	1.9
			kW	2.85	2.91	3.01	3.10	3.07	3.14	3.24	3.35	3.27	3.34	3.45	3.57	3.44	3.52	3.64	3.76	3.59	3.67	3.80	3.93	3.72	3.80	3.93	4.07
		1750	Amps	10.1	10.4	10.7	11.1	11.0	11.2	11.6	12.1	12.0	12.3	12.7	13.2	12.8	13.2	13.6	14.2	13.7	14.0	14.5	15.1	14.5	14.9	15.4	16.0
			Hi PR	225	242	246	251	255	274	278	284	290	311	316	323	330	355	360	368	371	399	405	414	416	447	453	463
		1530	Lo PR	119	123	134	143	123	127	138	147	127	131	143	152	130	135	147	156	133	137	150	160	136	141	154	163
			MBh	45.5	46.4	48.6	51.8	44.4	45.3	47.5	50.6	43.4	44.2	46.3	49.4	42.3	43.1	45.2	48.2	40.2	41.0	42.9	45.8	37.3	38.0	39.8	42.4
85		1970	S/T	0.92	0.89	0.80	0.65	0.95	0.92	0.83	0.67	0.98	0.94	0.85	0.69	1.00	0.97	0.88	0.71	1.00	1.00	0.91	0.74	1.00	1.00	0.92	0.75
			ΔT	2.5	2.5	2.3	2.0	2.5	2.5	2.4	2.1	2.5	2.5	2.4	2.1	2.5	2.5	2.4	2.1	2.4	2.5	2.4	2.1	2.2	2.3	2.2	1.9
		1750	kW	2.83	2.89	2.98	3.08	3.05	3.12	3.22	3.32	3.24	3.32	3.43	3.54	3.42	3.49	3.61	3.73	3.56	3.64	3.76	3.89	3.69	3.77	3.90	4.03
			Amps	10.0	10.3	10.6	11.0	10.9	11.1	11.5	12.0	11.9	12.2	12.6	13.1	12.7	13.0	13.5	14.0	13.6	13.9	14.4	15.0	14.4	14.8	15.3	15.9
		1530	Hi PR	223	240	243	249	252	271	275	281	287	308	313	320	327	351	356	364	367	395	401	409	411	442	449	459
			Lo PR	118	122	133	142	122	125	137	146	126	130	142	151	129	133	145	155	132	136	148	158	135	139	152	162

IDB	AIRFLOW	OUTDOOR AMBIENT TEMPERATURE																									
		65°F				75°F				85°F				95°F				105°F				115°F					
		59	63	67	71	59	63	67	71	59	63	67	71	59	63	67	71	59	63	67	71	59	63	67	71		
80	1970	MBh	49.9	51.0	54.5	58.2	48.7	49.8	53.2	56.9	47.6	48.6	52.0	55.5	46.4	47.4	50.7	54.2	44.1	45.1	48.1	51.5	40.9	41.7	44.6	47.7	
		S/T	0.95	0.89	0.73	0.54	1.00	0.93	0.75	0.56	1.00	0.95	0.77	0.58	1.00	1.00	0.80	0.60	1.00	1.00	0.83	0.62	1.00	1.00	0.84	0.63	
	1750	ΔT	2.2	2.1	1.9	1.5	2.3	2.2	1.9	1.5	2.2	2.2	1.9	1.5	2.2	2.2	1.9	1.5	2.1	2.1	1.9	1.5	1.9	1.9	1.7	1.4	
		kW	2.87	2.94	3.03	3.13	3.10	3.17	3.27	3.38	3.30	3.37	3.48	3.60	3.47	3.55	3.67	3.80	3.62	3.70	3.83	3.96	3.75	3.84	3.97	4.10	
	1530	Amps	10.2	10.5	10.8	11.2	11.1	11.4	11.7	12.2	12.1	12.4	12.8	13.3	13.0	13.3	13.7	14.3	13.8	14.2	14.7	15.3	14.7	15.1	15.6	16.2	
		Hi PR	228	245	248	254	257	277	280	287	292	315	319	326	333	358	363	371	375	403	409	418	420	451	458	468	
	85	1970	Lo PR	121	124	136	145	124	128	140	149	128	132	145	154	132	136	148	158	134	139	151	161	138	142	155	165
			MBh	48.5	4																						

EXPANDED COOLING DATA — ASXC180601A* / CA*F4961*6*** +TXV / MBVC2000** -1 LOW STAGE

IDB	AIRFLOW	OUTDOOR AMBIENT TEMPERATURE																									
		65°F				75°F				85°F				95°F				105°F				115°F					
		59	63	67	71	59	63	67	71	59	63	67	71	59	63	67	71	59	63	67	71	59	63	67	71		
70	1520	MBh	42.4	43.9	48.1	-	41.4	42.9	47.0	-	40.4	41.9	45.9	-	39.4	40.8	44.7	-	37.4	38.8	42.5	-	34.7	35.9	39.4	-	
		S/T	0.73	0.61	0.42	-	0.75	0.63	0.44	-	0.77	0.65	0.45	-	0.80	0.67	0.46	-	0.83	0.69	0.48	-	0.83	0.70	0.48	-	
		ΔT	19	16	12	-	19	16	12	-	19	16	12	-	19	16	12	-	19	16	12	-	17	15	11	-	
	1350	kW	2.43	2.49	2.57	-	2.64	2.70	2.79	-	2.82	2.89	2.99	-	2.98	3.05	3.16	-	3.12	3.19	3.31	-	3.24	3.31	3.43	-	
		Amps	9.4	9.6	10.0	-	10.2	10.4	10.8	-	11.1	11.4	11.8	-	11.9	12.2	12.6	-	14.0	14.3	14.8	-	14.8	15.1	15.7	-	
		Hi PR	226	243	247	-	248	267	271	-	291	313	317	-	331	356	361	-	372	400	406	-	430	463	469	-	
	1180	Lo PR	118	122	133	-	121	125	137	-	125	129	141	-	129	133	145	-	131	136	148	-	135	139	152	-	
		MBh	41.1	42.6	46.7	-	40.2	41.6	45.6	-	39.2	40.6	44.5	-	38.3	39.6	43.4	-	36.3	37.7	41.3	-	33.7	34.9	38.2	-	
		S/T	0.69	0.58	0.40	-	0.72	0.60	0.42	-	0.74	0.62	0.43	-	0.76	0.64	0.44	-	0.79	0.66	0.46	-	0.80	0.66	0.46	-	
	75	1520	MBh	43.1	44.3	48.0	51.5	42.1	43.3	46.9	50.3	41.1	42.3	45.8	49.1	40.1	41.3	44.7	47.9	38.1	39.2	42.4	45.5	35.3	36.3	39.3	42.2
			S/T	0.83	0.74	0.56	0.36	0.86	0.77	0.58	0.37	0.88	0.79	0.59	0.38	0.91	0.81	0.61	0.39	0.94	0.84	0.64	0.41	0.95	0.85	0.64	0.41
			ΔT	22	20	16	11	22	20	16	11	22	20	16	11	22	20	17	11	22	20	16	11	20	19	15	11
1350		kW	2.43	2.49	2.57	2.67	2.64	2.70	2.79	2.89	2.82	2.89	2.99	3.10	2.98	3.05	3.16	3.28	3.12	3.19	3.31	3.43	3.24	3.31	3.43	3.56	
		Amps	9.4	9.6	10.0	10.3	10.2	10.4	10.8	11.2	11.1	11.4	11.8	12.2	11.9	12.2	12.6	13.1	14.0	14.3	14.8	15.4	14.8	15.1	15.7	16.3	
		Hi PR	226	243	247	252	248	267	271	277	291	313	317	324	331	356	361	369	372	400	406	415	430	463	469	480	
1180		Lo PR	118	122	133	141	121	125	137	146	125	129	141	150	129	133	145	154	131	136	148	158	135	139	152	161	
		MBh	41.8	43.1	46.6	50.0	40.8	42.1	45.5	48.9	39.9	41.1	44.4	47.7	38.9	40.1	43.4	46.5	37.0	38.0	41.2	44.2	34.2	35.2	38.1	40.9	
		S/T	0.79	0.70	0.53	0.34	0.82	0.73	0.55	0.36	0.84	0.75	0.57	0.36	0.86	0.77	0.59	0.38	0.90	0.80	0.61	0.39	0.90	0.81	0.61	0.39	
75		1520	MBh	43.1	44.3	48.0	51.5	42.1	43.3	46.9	50.3	41.1	42.3	45.8	49.1	40.1	41.3	44.7	47.9	38.1	39.2	42.4	45.5	35.3	36.3	39.3	42.2
			S/T	0.83	0.74	0.56	0.36	0.86	0.77	0.58	0.37	0.88	0.79	0.59	0.38	0.91	0.81	0.61	0.39	0.94	0.84	0.64	0.41	0.95	0.85	0.64	0.41
			ΔT	22	20	16	11	22	20	16	11	22	20	16	11	22	20	17	11	22	20	16	11	20	19	15	11
	1350	kW	2.41	2.47	2.55	2.64	2.61	2.68	2.77	2.87	2.80	2.86	2.96	3.07	2.95	3.03	3.13	3.25	3.09	3.16	3.28	3.40	3.21	3.28	3.40	3.53	
		Amps	9.3	9.5	9.9	10.2	10.1	10.3	10.7	11.1	11.0	11.3	11.7	12.1	11.8	12.1	12.5	13.0	13.8	14.2	14.7	15.3	14.6	15.0	15.5	16.1	
		Hi PR	224	241	244	250	246	264	268	274	288	309	314	321	328	352	357	365	369	397	402	411	426	458	465	475	
	1180	Lo PR	117	120	131	140	120	124	135	144	124	128	140	149	128	132	144	153	130	134	146	156	133	137	150	160	
		MBh	38.6	39.7	43.0	46.2	37.7	38.8	42.0	45.1	36.8	37.9	41.0	44.0	35.9	37.0	40.0	42.9	34.1	35.1	38.0	40.8	31.6	32.5	35.2	37.8	
		S/T	0.76	0.68	0.51	0.33	0.79	0.70	0.53	0.34	0.81	0.72	0.55	0.35	0.83	0.75	0.56	0.36	0.87	0.77	0.59	0.38	0.87	0.78	0.59	0.38	
	75	1520	MBh	43.1	44.3	48.0	51.5	42.1	43.3	46.9	50.3	41.1	42.3	45.8	49.1	40.1	41.3	44.7	47.9	38.1	39.2	42.4	45.5	35.3	36.3	39.3	42.2
			S/T	0.83	0.74	0.56	0.36	0.86	0.77	0.58	0.37	0.88	0.79	0.59	0.38	0.91	0.81	0.61	0.39	0.94	0.84	0.64	0.41	0.95	0.85	0.64	0.41
			ΔT	22	20	16	11	22	20	16	11	22	20	16	11	22	20	17	11	22	20	16	11	20	19	15	11
1350		kW	2.41	2.47	2.55	2.64	2.61	2.68	2.77	2.87	2.80	2.86	2.96	3.07	2.95	3.03	3.13	3.25	3.09	3.16	3.28	3.40	3.21	3.28	3.40	3.53	
		Amps	9.3	9.5	9.9	10.2	10.1	10.3	10.7	11.1	11.0	11.3	11.7	12.1	11.8	12.1	12.5	13.0	13.8	14.2	14.7	15.3	14.6	15.0	15.5	16.1	
		Hi PR	224	241	244	250	246	264	268	274	288	309	314	321	328	352	357	365	369	397	402	411	426	458	465	475	
1180		Lo PR	117	120	131	140	120	124	135	144	124	128	140	149	128	132	144	153	130	134	146	156	133	137	150	160	
		MBh	38.6	39.7	43.0	46.2	37.7	38.8	42.0	45.1	36.8	37.9	41.0	44.0	35.9	37.0	40.0	42.9	34.1	35.1	38.0	40.8	31.6	32.5	35.2	37.8	
		S/T	0.76	0.68	0.51	0.33	0.79	0.70	0.53	0.34	0.81	0.72	0.55	0.35	0.83	0.75	0.56	0.36	0.87	0.77	0.59	0.38	0.87	0.78	0.59	0.38	
75		1520	MBh	43.1	44.3	48.0	51.5	42.1	43.3	46.9	50.3	41.1	42.3	45.8	49.1	40.1	41.3	44.7	47.9	38.1	39.2	42.4	45.5	35.3	36.3	39.3	42.2
			S/T	0.83	0.74	0.56	0.36	0.86	0.77	0.58	0.37	0.88	0.79	0.59	0.38	0.91	0.81	0.61	0.39	0.94	0.84	0.64	0.41	0.95	0.85	0.64	0.41
			ΔT	22	20	16	11	22	20	16	11	22	20	16	11	22	20	17	11	22	20	16	11	20	19	15	11
	1350	kW	2.41	2.47	2.55	2.64	2.61	2.68	2.77	2.87	2.80	2.86	2.96	3.07	2.95	3.03	3.13	3.25	3.09	3.16	3.28	3.40	3.21	3.28	3.40	3.53	
		Amps	9.3	9.5	9.9	10.2	10.1	10.3	10.7	11.1	11.0	11.3	11.7	12.1	11.8	12.1	12.5	13.0	13.8	14.2	14.7	15.3	14.6	15.0	15.5	16.1	
		Hi PR	224	241	244	250	246	264	268	274	288	309	314	321	328	352	357	365	369	397	402	411	426	458	465	475	
	1180	Lo PR	117	120	131	140	120	124	135	144	124	128	140	149	128	132	144	153	130	134	146	156	133	137	150	160	
		MBh	38.6	39.7	43.0	46.2	37.7	38.8	42.0	45.1	36.8	37.9	41.0	44.0	35.9	37.0	40.0	42.9	34.1	35.1	38.0	40.8	31.6	32.5	35.2	37.8	
		S/T	0.76	0.68	0.51	0.33	0.79	0.70	0.53	0.34	0.81	0.72	0.55	0.35	0.83	0.75	0.56	0.36	0.87	0.77	0.59	0.38	0.87	0.78	0.59	0.38	
	75	1520	MBh	43.1	44.3	48.0	51.5	42.1	43.3	46.9	50.3	41.1	42.3	45.8	49.1	40.1	41.3	44.7	47.9	38.1	39.2	42.4	45.5	35.3	36.3	39.3	42.2
			S/T	0.83	0.74	0.56	0.36	0.86	0.77	0.58	0.37	0.88	0.79	0.59	0.38	0.91	0.81	0.61	0.39	0.94	0.84	0.64	0.41	0.95	0.85	0.64	0.41
			ΔT	22	20	16	11	22	20	16	11	22	20	16	11	22	20	17	11	22	20	16	11	20	19	15	11
1350		kW	2.41	2.47	2.55	2.64	2.61	2.68	2.77	2.87	2.80	2.86	2.96	3.07	2.95	3.03	3.13	3.25	3.09	3.16	3.28	3.40	3.21	3.28	3.40	3.53	
		Amps	9.3	9.5	9.9	10.2	10.1	10.3	10.7	11.1	11.0	11.3	11.7	12.1	11.8	12.1	12.5	13.0	13.8	14.2	14.7	15.3	14.6	15.0	15.5	16.1	
		Hi PR	224	241	244	250	246	264	268	274	288	309	314	321	328	352	357	365	369	397	402	411	426	458	465	475	
1180		Lo PR	117	120	131	140	120	124	135	144	124	128	140	149	128	132	144	153	130	134	146	156	133	137	150	160	
		MBh	38.6	39.7	43.0	46.2	37.7	38.8	42.0	45.1																	

EXPANDED COOLING DATA — ASXC180601A* / CA*F4961*6** +TXV / MBVC2000** -1 Low Stage (CONT.)

IDB	AIRFLOW	OUTDOOR AMBIENT TEMPERATURE												ENTERING INDOOR WET BULB TEMPERATURE											
		65°F				75°F				85°F				95°F				105°F				115°F			
		59	63	67	71	59	63	67	71	59	63	67	71	59	63	67	71	59	63	67	71	59	63	67	71
80	MBh	43.8	44.8	47.9	51.2	42.8	43.8	46.7	50.0	41.8	42.7	45.6	48.8	40.8	41.7	44.5	47.6	38.7	39.6	42.3	45.2	35.9	36.7	39.2	41.9
	S/T	0.91	0.85	0.69	0.52	0.94	0.88	0.72	0.54	0.96	0.90	0.74	0.55	1.00	0.93	0.76	0.57	1.00	0.97	0.79	0.59	1.00	1.00	0.79	0.59
	ΔT	24	23	20	16	24	23	20	16	25	23	20	16	25	23	20	16	23	23	20	16	22	22	19	15
	kW	2.43	2.49	2.57	2.67	2.64	2.70	2.79	2.89	2.82	2.89	2.99	3.10	2.98	3.05	3.16	3.28	3.12	3.19	3.31	3.43	3.24	3.31	3.43	3.56
	Amps	9.4	9.6	10.0	10.3	10.2	10.4	10.8	11.2	11.1	11.4	11.8	12.2	11.9	12.2	12.6	13.1	14.0	14.3	14.8	15.4	14.8	15.1	15.7	16.3
	HI PR	226	243	247	252	248	267	271	277	291	313	317	324	331	356	361	369	372	400	406	415	430	463	469	480
	Lo PR	118	122	133	141	121	125	137	146	125	129	141	150	129	133	145	154	131	136	148	158	135	139	152	161
	MBh	42.6	43.5	46.5	49.7	41.6	42.5	45.4	48.5	40.6	41.5	44.3	47.4	39.6	40.5	43.2	46.2	37.6	38.4	41.1	43.9	34.8	35.6	38.0	40.7
	S/T	0.86	0.81	0.66	0.49	0.90	0.84	0.68	0.51	0.92	0.86	0.70	0.52	0.95	0.89	0.72	0.54	0.98	0.92	0.75	0.56	0.99	0.93	0.76	0.57
	ΔT	25	24	21	17	25	24	21	17	25	24	21	17	26	24	21	17	25	24	21	17	24	23	20	16
kW	2.41	2.47	2.55	2.64	2.61	2.68	2.77	2.87	2.80	2.86	2.96	3.07	2.95	3.03	3.13	3.25	3.09	3.16	3.28	3.40	3.21	3.28	3.40	3.53	
Amps	9.3	9.5	9.9	10.2	10.1	10.3	10.7	11.1	11.0	11.3	11.7	12.1	11.8	12.1	12.5	13.0	13.8	14.2	14.7	15.3	14.6	15.0	15.5	16.1	
HI PR	224	241	244	250	246	264	268	274	288	309	314	321	328	352	357	365	369	397	402	411	426	458	465	475	
Lo PR	117	120	131	140	120	124	135	144	124	128	140	149	128	132	144	153	130	134	146	156	133	137	150	160	
MBh	39.3	40.1	42.9	45.8	38.4	39.2	41.9	44.8	37.5	38.3	40.9	43.7	36.5	37.3	39.9	42.6	34.7	35.5	37.9	40.5	32.2	32.9	35.1	37.5	
S/T	0.83	0.78	0.64	0.48	0.86	0.81	0.66	0.49	0.89	0.83	0.68	0.51	0.91	0.86	0.70	0.52	0.95	0.89	0.72	0.54	0.96	0.90	0.73	0.55	
ΔT	26	24	21	17	26	25	22	17	26	25	22	17	26	25	22	17	26	25	22	17	24	23	20	16	
kW	2.39	2.44	2.53	2.62	2.59	2.65	2.75	2.84	2.77	2.84	2.94	3.04	2.93	3.00	3.10	3.22	3.06	3.14	3.25	3.37	3.18	3.25	3.37	3.49	
Amps	9.2	9.4	9.8	10.1	10.0	10.2	10.6	11.0	10.9	11.2	11.6	12.0	11.7	12.0	12.4	12.9	13.7	14.0	14.5	15.1	14.5	14.8	15.4	16.0	
HI PR	222	238	242	247	243	262	265	271	285	306	311	318	325	349	354	362	365	393	398	407	422	454	460	470	
Lo PR	116	119	130	139	119	123	134	143	123	127	138	147	126	130	142	151	129	133	145	154	132	136	149	158	

1520	MBh	44.6	45.5	47.6	50.8	43.6	44.4	46.5	49.6	42.5	43.4	45.4	48.4	41.5	42.3	44.3	47.3	39.4	40.2	42.1	44.9	36.5	37.2	39.0	41.6
	S/T	0.95	0.92	0.83	0.67	0.98	0.95	0.86	0.70	1.00	0.97	0.88	0.71	1.00	1.00	0.91	0.74	1.00	1.00	0.94	0.76	1.00	1.00	0.95	0.77
	ΔT	26	25	24	21	26	26	24	21	26	26	24	21	25	26	24	21	24	24	24	21	22	23	22	19
	kW	2.43	2.49	2.57	2.67	2.64	2.70	2.79	2.89	2.82	2.89	2.99	3.10	2.98	3.05	3.16	3.28	3.12	3.19	3.31	3.43	3.24	3.31	3.43	3.56
	Amps	9.4	9.6	10.0	10.3	10.2	10.4	10.8	11.2	11.1	11.4	11.8	12.2	11.9	12.2	12.6	13.1	14.0	14.3	14.8	15.4	14.8	15.1	15.7	16.3
	HI PR	226	243	247	252	248	267	271	277	291	313	317	324	331	356	361	369	372	400	406	415	430	463	469	480
	Lo PR	118	122	133	141	121	125	137	146	125	129	141	150	129	133	145	154	131	136	148	158	135	139	152	161
	MBh	43.3	44.1	46.2	49.3	42.3	43.1	45.2	48.2	41.3	42.1	44.1	47.0	40.3	41.1	43.0	45.9	38.3	39.0	40.9	43.6	35.4	36.1	37.8	40.4
	S/T	0.91	0.87	0.79	0.64	0.94	0.91	0.82	0.66	0.96	0.93	0.84	0.68	0.99	0.96	0.87	0.70	1.00	1.00	0.90	0.73	1.00	1.00	0.91	0.73
	ΔT	27	26	25	22	27	27	25	22	27	27	25	22	27	27	25	22	26	26	25	22	24	25	23	20
kW	2.41	2.47	2.55	2.64	2.61	2.68	2.77	2.87	2.80	2.86	2.96	3.07	2.95	3.03	3.13	3.25	3.09	3.16	3.28	3.40	3.21	3.28	3.40	3.53	
Amps	9.3	9.5	9.9	10.2	10.1	10.3	10.7	11.1	11.0	11.3	11.7	12.1	11.8	12.1	12.5	13.0	13.8	14.2	14.7	15.3	14.6	15.0	15.5	16.1	
HI PR	224	241	244	250	246	264	268	274	288	309	314	321	328	352	357	365	369	397	402	411	426	458	465	475	
Lo PR	117	120	131	140	120	124	135	144	124	128	140	149	128	132	144	153	130	134	146	156	133	137	150	160	
MBh	40.0	40.7	42.7	45.5	39.0	39.8	41.7	44.5	38.1	38.8	40.7	43.4	37.2	37.9	39.7	42.3	35.3	36.0	37.7	40.2	32.7	33.4	34.9	37.3	
S/T	0.87	0.84	0.76	0.62	0.91	0.87	0.79	0.64	0.93	0.90	0.81	0.66	0.96	0.92	0.83	0.68	0.99	0.96	0.87	0.70	1.00	0.97	0.87	0.71	
ΔT	27.2	27	25	22	28	27	26	22	28	27	26	22	28	27	26	22	27	27	25	22	25	25	24	21	
kW	2.39	2.44	2.53	2.62	2.59	2.65	2.75	2.84	2.77	2.84	2.94	3.04	2.93	3.00	3.10	3.22	3.06	3.14	3.25	3.37	3.18	3.25	3.37	3.49	
Amps	9.2	9.4	9.8	10.1	10.0	10.2	10.6	11.0	10.9	11.2	11.6	12.0	11.7	12.0	12.4	12.9	13.7	14.0	14.5	15.1	14.5	14.8	15.4	16.0	
HI PR	222	238	242	247	243	262	265	271	285	306	311	318	325	349	354	362	365	393	398	407	422	454	460	470	
Lo PR	116	119	130	139	119	123	134	143	123	127	138	147	126	130	142	151	129	133	145	154	132	136	149	158	

kW = Total system power
Amps = outdoor unit amps (comp. + fan)

Shaded area is AHRI (TVA) conditions

IDB = Entering Indoor Dry Bulb Temperature
High and low pressures are measured at the liquid and suction service valves.

EXPANDED COOLING DATA — ASXC180601A* / CA*F4961*6*** +TXV / MBVC2000** -1 HIGH STAGE

IDB	AIRFLOW	OUTDOOR AMBIENT TEMPERATURE																								
		65°F				75°F				85°F				95°F				105°F				115°F				
		59	63	67	71	59	63	67	71	59	63	67	71	59	63	67	71	59	63	67	71	59	63	67	71	
70	2250	MBh	58.5	60.6	66.4	-	57.1	59.2	64.9	-	55.8	57.8	63.3	-	54.4	56.4	61.8	-	51.7	53.6	58.7	-	47.9	49.6	54.4	-
		S/T	0.73	0.61	0.42	-	0.76	0.63	0.44	-	0.78	0.65	0.45	-	0.80	0.67	0.47	-	0.83	0.70	0.48	-	0.84	0.70	0.49	-
	ΔT	18	15	12	-	18	15	12	-	18	15	12	-	18	15	12	-	18	15	12	-	16	14	11	-	
	kW	3.87	3.96	4.09	-	4.18	4.27	4.41	-	4.45	4.55	4.70	-	4.69	4.80	4.96	-	4.89	5.00	5.17	-	5.07	5.18	5.36	-	
	Amps	13.8	14.2	14.7	-	15.0	15.4	15.9	-	16.4	16.8	17.4	-	17.6	18.0	18.7	-	20.6	21.2	21.9	-	21.8	22.4	23.2	-	
	Hi PR	241	259	263	-	265	285	289	-	310	333	338	-	353	380	385	-	397	427	433	-	459	493	500	-	
	Lo PR	115	119	130	-	118	122	133	-	123	126	138	-	126	130	142	-	128	132	144	-	131	136	148	-	
	MBh	56.8	58.9	64.5	-	55.5	57.5	63.0	-	54.2	56.1	61.5	-	52.8	54.8	60.0	-	50.2	52.0	57.0	-	46.5	48.2	52.8	-	
	S/T	0.70	0.58	0.40	-	0.72	0.60	0.42	-	0.74	0.62	0.43	-	0.77	0.64	0.44	-	0.80	0.66	0.46	-	0.80	0.67	0.46	-	
	ΔT	18	16	12	-	18	16	12	-	18	16	12	-	19	16	12	-	18	16	12	-	17	15	11	-	
	kW	3.84	3.93	4.05	-	4.15	4.24	4.38	-	4.41	4.51	4.66	-	4.65	4.75	4.91	-	4.85	4.96	5.13	-	5.02	5.14	5.31	-	
	Amps	13.7	14.0	14.5	-	14.9	15.2	15.8	-	16.2	16.6	17.2	-	17.4	17.8	18.5	-	20.4	21.0	21.7	-	21.6	22.2	23.0	-	
Hi PR	239	257	260	-	262	282	286	-	307	330	335	-	349	376	381	-	393	423	429	-	454	488	495	-		
Lo PR	114	118	128	-	117	121	132	-	121	125	137	-	125	128	140	-	127	131	143	-	130	134	147	-		
MBh	52.4	54.3	59.5	-	51.2	53.1	58.1	-	50.0	51.8	56.8	-	48.8	50.5	55.4	-	46.3	48.0	52.6	-	42.9	44.5	48.7	-		
S/T	0.67	0.56	0.39	-	0.70	0.58	0.40	-	0.72	0.60	0.41	-	0.74	0.62	0.43	-	0.77	0.64	0.44	-	0.77	0.65	0.45	-		
ΔT	19	16	12	-	19	16	12	-	19	16	12	-	19	16	12	-	19	16	12	-	17	15	11	-		
kW	3.81	3.89	4.02	-	4.11	4.20	4.34	-	4.38	4.47	4.62	-	4.61	4.71	4.87	-	4.81	4.92	5.08	-	4.98	5.09	5.27	-		
Amps	13.5	13.9	14.4	-	14.7	15.1	15.6	-	16.1	16.5	17.1	-	17.2	17.7	18.3	-	20.2	20.8	21.5	-	21.4	22.0	22.7	-		
Hi PR	236	254	258	-	259	279	283	-	304	327	331	-	346	372	377	-	389	419	424	-	450	484	490	-		
Lo PR	113	116	127	-	116	120	131	-	120	124	135	-	123	127	139	-	126	130	142	-	129	133	145	-		

75	2250	MBh	59.5	61.3	66.3	71.2	58.1	59.8	64.8	69.5	56.7	58.4	63.2	67.8	55.3	57.0	61.7	66.2	52.6	54.1	58.6	62.9	48.7	50.1	54.3	58.3
		S/T	0.83	0.75	0.56	0.36	0.86	0.77	0.58	0.38	0.89	0.79	0.60	0.39	0.91	0.82	0.62	0.40	0.95	0.85	0.64	0.41	0.96	0.86	0.65	0.42
	ΔT	20	19	15	11	20	19	15	11	21	19	15	11	21	19	16	11	21	19	15	11	19	18	14	10	
	kW	3.87	3.96	4.09	4.22	4.18	4.27	4.41	4.56	4.45	4.55	4.70	4.86	4.69	4.80	4.96	5.13	4.89	5.00	5.17	5.35	5.07	5.18	5.36	5.55	
	Amps	13.8	14.2	14.7	15.2	15.0	15.4	15.9	16.6	16.4	16.8	17.4	18.1	17.6	18.0	18.7	19.4	20.6	21.2	21.9	22.8	21.8	22.4	23.2	24.1	
	Hi PR	241	259	263	269	265	285	289	295	310	333	338	345	353	380	385	393	397	427	433	443	459	493	500	511	
	Lo PR	115	119	130	138	118	122	133	142	123	126	138	147	126	130	142	151	128	132	144	154	131	136	148	158	
	MBh	57.8	59.5	64.4	69.1	56.4	58.1	62.9	67.5	55.1	56.7	61.4	65.9	53.7	55.3	59.9	64.3	51.0	52.6	56.9	61.1	47.3	48.7	52.7	56.6	
	S/T	0.79	0.71	0.54	0.35	0.82	0.74	0.56	0.36	0.84	0.76	0.57	0.37	0.87	0.78	0.59	0.38	0.90	0.81	0.61	0.39	0.91	0.82	0.62	0.40	
	ΔT	21	19	16	11	21	20	16	11	21	20	16	11	22	20	16	11	21	20	16	11	20	18	15	10	
	kW	3.84	3.93	4.05	4.19	4.15	4.24	4.38	4.52	4.41	4.51	4.66	4.82	4.65	4.75	4.91	5.08	4.85	4.96	5.13	5.31	5.02	5.14	5.31	5.50	
	Amps	13.7	14.0	14.5	15.1	14.9	15.2	15.8	16.4	16.2	16.6	17.2	17.9	17.4	17.8	18.5	19.2	20.4	21.0	21.7	22.6	21.6	22.2	23.0	23.9	
Hi PR	239	257	260	266	262	282	286	292	307	330	335	342	349	376	381	389	393	423	429	438	454	488	495	506		
Lo PR	114	118	128	137	117	121	132	141	121	125	137	145	125	128	140	149	127	131	143	152	130	134	147	156		
MBh	53.3	54.9	59.4	63.8	52.1	53.6	58.0	62.3	50.8	52.3	56.7	60.8	49.6	51.1	55.3	59.3	47.1	48.5	52.5	56.4	43.6	44.9	48.6	52.2		
S/T	0.77	0.69	0.52	0.33	0.79	0.71	0.54	0.35	0.81	0.73	0.55	0.35	0.84	0.75	0.57	0.37	0.87	0.78	0.59	0.38	0.88	0.79	0.60	0.38		
ΔT	21	20	16	11	22	20	16	11	22	20	16	11	22	20	17	11	22	20	16	11	20	19	15	11		
kW	3.81	3.89	4.02	4.15	4.11	4.20	4.34	4.49	4.38	4.47	4.62	4.78	4.61	4.71	4.87	5.04	4.81	4.92	5.08	5.26	4.98	5.09	5.27	5.45		
Amps	13.5	13.9	14.4	14.9	14.7	15.1	15.6	16.2	16.1	16.5	17.1	17.7	17.2	17.7	18.3	19.0	20.2	20.8	21.5	22.3	21.4	22.0	22.7	23.6		
Hi PR	236	254	258	263	259	279	283	289	304	327	331	339	346	372	377	386	389	419	424	434	450	484	490	501		
Lo PR	113	116	127	135	116	120	131	139	120	124	135	144	123	127	139	148	126	130	142	151	129	133	145	155		

IDB = Entering Indoor Dry Bulb Temperature
 High and low pressures are measured at the liquid and suction service valves.
 Shaded area is ACCA (TVA) conditions
 kW = Total system power
 Amps = outdoor unit amps (comp. + fan)

EXPANDED COOLING DATA — ASXC180601A* / CA*F4961*6** +TXV / MBVC2000** -1 HIGH STAGE (CONT.)

IDB	AIRFLOW	OUTDOOR AMBIENT TEMPERATURE												ENTERING INDOOR WET BULB TEMPERATURE													
		65°F				75°F				85°F				95°F				105°F				115°F					
		59	63	67	71	59	63	67	71	59	63	67	71	59	63	67	71	59	63	67	71	59	63	67	71		
80	2250	MBh	60.6	61.9	66.1	70.7	59.1	60.4	64.6	69.0	57.7	59.0	63.0	67.4	56.3	57.6	61.5	65.7	53.5	54.7	58.4	62.4	49.6	50.6	54.1	57.8	
		S/T	0.91	0.86	0.70	0.52	0.95	0.89	0.72	0.54	1.00	0.91	0.74	0.55	1.00	0.94	0.77	0.57	1.00	1.00	0.79	0.59	1.00	1.00	0.80	0.60	
	2000	ΔT	23	22	19	15	24	22	19	15	23	22	19	15	23	22	19	15	22	22	19	15	20	21	18	14	
		kW	3.87	3.96	4.09	4.22	4.18	4.27	4.41	4.56	4.45	4.55	4.70	4.86	4.69	4.80	4.96	5.13	4.89	5.00	5.17	5.35	5.07	5.18	5.36	5.55	
	1750	Amps	13.8	14.2	14.7	15.2	15.0	15.4	15.9	16.6	16.4	16.8	17.4	18.1	17.6	18.0	18.7	19.4	20.6	21.2	21.9	22.8	21.8	22.4	23.2	24.1	
		HI PR	241	259	263	269	265	285	289	295	310	333	338	345	353	380	385	393	397	427	433	443	459	493	500	511	
	85	2250	Lo PR	115	119	130	138	118	122	133	142	123	126	138	147	126	130	142	151	128	132	144	154	131	136	148	158
			MBh	58.8	60.1	64.2	68.6	57.4	58.7	62.7	67.0	56.1	57.3	61.2	65.4	54.7	55.9	59.7	63.8	52.0	53.1	56.7	60.6	48.1	49.2	52.5	56.2
		2000	S/T	0.87	0.82	0.67	0.50	0.90	0.85	0.69	0.52	0.93	0.87	0.71	0.53	0.96	0.90	0.73	0.55	0.99	0.93	0.76	0.57	1.00	0.94	0.76	0.57
			ΔT	24	23	20	16	24	23	20	16	24	23	20	16	24	23	20	16	24	23	20	16	22	21	18	15
1750		kW	3.84	3.93	4.05	4.19	4.15	4.24	4.38	4.52	4.41	4.51	4.66	4.82	4.65	4.75	4.91	5.08	4.85	4.96	5.13	5.31	5.02	5.14	5.31	5.50	
		Amps	13.7	14.0	14.5	15.1	14.9	15.2	15.8	16.4	16.2	16.6	17.2	17.9	17.4	17.8	18.5	19.2	20.4	21.0	21.7	22.6	21.6	22.2	23.0	23.9	
85		2250	HI PR	239	257	260	266	262	282	286	292	307	330	335	342	349	376	381	389	393	423	429	438	454	488	495	506
			Lo PR	114	118	128	137	117	121	132	141	121	125	137	145	125	128	140	149	127	131	143	152	130	134	147	156
		2000	MBh	54.3	55.4	59.2	63.3	53.0	54.2	57.9	61.9	51.7	52.9	56.5	60.4	50.5	51.6	55.1	58.9	48.0	49.0	52.3	56.0	44.4	45.4	48.5	51.8
			S/T	0.84	0.79	0.64	0.48	0.87	0.82	0.66	0.50	0.89	0.84	0.68	0.51	0.92	0.86	0.70	0.53	0.96	0.90	0.73	0.55	0.96	0.90	0.74	0.55
	1750	ΔT	24	23	20	16	24	23	20	16	24	23	20	16	24	23	20	16	24	23	20	16	23	22	19	15	
		kW	3.81	3.89	4.02	4.15	4.11	4.20	4.34	4.49	4.38	4.47	4.62	4.78	4.61	4.71	4.87	5.04	4.81	4.92	5.08	5.26	4.98	5.09	5.27	5.45	
	85	2250	Amps	13.5	13.9	14.4	14.9	14.7	15.1	15.6	16.2	16.1	16.5	17.1	17.7	17.2	17.7	18.3	19.0	20.2	20.8	21.5	22.3	21.4	22.0	22.7	23.6
			HI PR	236	254	258	263	259	279	283	289	304	327	331	339	346	372	377	386	389	419	424	434	450	484	490	501
		2000	Lo PR	113	116	127	135	116	120	131	139	120	124	135	144	123	127	139	148	126	130	142	151	129	133	145	155
			MBh	61.6	62.8	65.8	70.2	60.2	61.3	64.2	68.5	58.7	59.9	62.7	66.9	57.3	58.4	61.2	65.3	54.4	55.5	58.1	62.0	50.4	51.4	53.8	57.4
1750		S/T	0.96	0.92	0.83	0.68	0.99	0.96	0.86	0.70	1.00	0.98	0.89	0.72	1.00	1.00	0.91	0.74	1.00	1.00	0.95	0.77	1.00	1.00	0.96	0.78	
		ΔT	24	24	22	19	24	24	23	20	24	24	23	20	23	24	23	20	22	23	23	20	21	21	21	18	
85		2250	kW	3.87	3.96	4.09	4.22	4.18	4.27	4.41	4.56	4.45	4.55	4.70	4.86	4.69	4.80	4.96	5.13	4.89	5.00	5.17	5.35	5.07	5.18	5.36	5.55
			Amps	13.8	14.2	14.7	15.2	15.0	15.4	15.9	16.6	16.4	16.8	17.4	18.1	17.6	18.0	18.7	19.4	20.6	21.2	21.9	22.8	21.8	22.4	23.2	24.1
		2000	HI PR	241	259	263	269	265	285	289	295	310	333	338	345	353	380	385	393	397	427	433	443	459	493	500	511
			Lo PR	115	119	130	138	118	122	133	142	123	126	138	147	126	130	142	151	128	132	144	154	131	136	148	158
	1750	MBh	59.8	61.0	63.9	68.1	58.4	59.6	62.4	66.5	57.0	58.1	60.9	65.0	55.6	56.7	59.4	63.4	52.9	53.9	56.4	60.2	49.0	49.9	52.3	55.8	
		S/T	0.91	0.88	0.80	0.65	0.95	0.91	0.82	0.67	0.97	0.94	0.85	0.69	1.00	0.97	0.87	0.71	1.00	1.00	0.91	0.73	1.00	1.00	0.91	0.74	
	85	2250	ΔT	25	25	23	20	25	25	24	20	25	25	24	20	26	25	24	21	24	25	23	20	23	23	22	19
			kW	3.84	3.93	4.05	4.19	4.15	4.24	4.38	4.52	4.41	4.51	4.66	4.82	4.65	4.75	4.91	5.08	4.85	4.96	5.13	5.31	5.02	5.14	5.31	5.50
		2000	Amps	13.7	14.0	14.5	15.1	14.9	15.2	15.8	16.4	16.2	16.6	17.2	17.9	17.4	17.8	18.5	19.2	20.4	21.0	21.7	22.6	21.6	22.2	23.0	23.9
			HI PR	239	257	260	266	262	282	286	292	307	330	335	342	349	376	381	389	393	423	429	438	454	488	495	506
1750		Lo PR	114	118	128	137	117	121	132	141	121	125	137	145	125	128	140	149	127	131	143	152	130	134	147	156	
		MBh	55.2	56.3	58.9	62.9	53.9	55.0	57.6	61.4	52.6	53.7	56.2	60.0	51.4	52.4	54.8	58.5	48.8	49.7	52.1	55.6	45.2	46.1	48.2	51.5	
85		2250	S/T	0.88	0.85	0.77	0.62	0.91	0.88	0.79	0.64	0.94	0.90	0.82	0.66	0.97	0.93	0.84	0.68	1.00	0.97	0.87	0.71	1.00	0.98	0.88	0.71
			ΔT	26	25	24	21	26	25	24	21	26	25	24	21	26	26	24	21	26	25	24	21	24	24	22	19
		2000	kW	3.81	3.89	4.02	4.15	4.11	4.20	4.34	4.49	4.38	4.47	4.62	4.78	4.61	4.71	4.87	5.04	4.81	4.92	5.08	5.26	4.98	5.09	5.27	5.45
			Amps	13.5	13.9	14.4	14.9	14.7	15.1	15.6	16.2	16.1	16.5	17.1	17.7	17.2	17.7	18.3	19.0	20.2	20.8	21.5	22.3	21.4	22.0	22.7	23.6
	1750	HI PR	236	254	258	263	259	279	283	289	304	327	331	339	346	372	377	386	389	419	424	434	450	484	490	501	
		Lo PR	113	116	127	135	116	120	131	139	120	124	135	144	123	127	139	148	126	130	142	151	129	133	145	155	

IDB = Entering Indoor Dry Bulb Temperature
 High and low pressures are measured at the liquid and suction service valves.
 Shaded area is AHRI (TVA) conditions
 kW = Total system power
 Amps = outdoor unit amps (comp. + fan)

AHRI PERFORMANCE DATA

OUTDOOR UNIT	INDOOR UNITS		COOLING CAPACITY (BTU/H)				ARI #
	COIL & BLOWER UNITS	FURNACE	TOTAL	SENSIBLE	SEER ¹	EER ²	
ASXC18 0361A*	AEPF313716A*+TXV		35,000	25,600	18.00	13.00	3610364
	AEPF426016C*+TXV		35,000	25,600	18.00	13.00	3610365
	AVPTC313714A*		35,000	25,600	18.00	13.00	4431356
	AVPTC426014A*		35,000	25,600	18.00	13.00	4431357
	CA*F3743*6A*+TXV	MBE1600**-1B*	35,000	25,600	18.00	13.00	3610366
	CA*F3743*6A*+TXV	MBE2000**-1B*	35,000	25,600	18.00	13.00	3610652
	CA*F3743*6A*+TXV	MBVC1600**-1A*	35,000	25,600	18.00	13.00	3610622
	CA*F3743*6A*+TXV	MBVC2000**-1A*	35,000	25,600	18.00	13.00	3610623
	CA*F3743*6A*+TXV	G*VC950714CXA*	35,000	25,600	17.50	13.00	4202543
	CA*F3743*6A*+TXV	A*VC950714CXA*	35,000	25,600	17.50	13.00	4202542
	CA*F3743*6A*+TXV	G*VC950905CXA*	35,000	25,600	18.00	13.25	4200720
	CA*F3743*6A*+TXV	A*VC950905CXA*	35,000	25,600	18.00	13.25	4200718
	CA*F3743*6A*+TXV	G*VC950915DXA*	35,000	25,600	18.00	13.25	4200055
	CA*F3743*6A*+TXV	A*VC950915DXA*	35,000	25,600	18.00	13.25	4200053
	CA*F3743*6A*+TXV	A*VC81155CXA*	35,000	25,600	17.00	13.00	3642604
	CA*F3743*6A*+TXV	A*VC80905CXA*	35,000	25,600	17.00	13.00	3629953
	CA*F3743*6A*+TXV	A*VC80704BXA*	35,000	25,600	17.00	13.00	3629942
	CA*F3743*6A*+TXV	G*VC951155DXA*	35,000	25,600	18.00	13.00	3610383
	CA*F3743*6A*+TXV	G*VC950905DXA*	35,000	25,600	18.00	13.25	3610382
	CA*F3743*6A*+TXV	G*VC950704CXA*	35,000	25,600	17.50	13.00	3610381
	CA*F3743*6A*+TXV	G*V951155D**	35,000	25,600	18.00	13.00	3610380
	CA*F3743*6A*+TXV	G*V950905D**	35,000	25,600	18.00	13.25	3610379
	CA*F3743*6A*+TXV	G*V950704C**	35,000	25,600	17.50	13.00	3610378
	CA*F3743*6A*+TXV	A*VC951155DXA*	35,000	25,600	18.00	13.00	3610377
	CA*F3743*6A*+TXV	A*VC950905DXA*	35,000	25,600	18.00	13.25	3610376
	CA*F3743*6A*+TXV	A*VC950704CXA*	35,000	25,600	17.50	13.00	3610375
	CA*F3743*6A*+TXV	A*VC90905DXA*	35,000	25,600	18.00	13.25	3610374
	CA*F3743*6A*+TXV	A*VC90704CXA*	35,000	25,600	17.50	13.00	3610373
	CA*F3743*6A*+TXV	A*V91155D**	35,000	25,600	18.00	13.00	3610372
	CA*F3743*6A*+TXV	A*V90905D**	35,000	25,600	18.00	13.25	3610371
	CA*F3743*6A*+TXV	A*V90704C**	35,000	25,600	17.50	13.00	3610370
	CA*F3743*6A*+TXV	A*V81155C**	35,000	25,600	17.00	13.00	3610369
	CA*F3743*6A*+TXV	A*V80905C**	35,000	25,600	17.00	13.00	3610368
	CA*F3743*6A*+TXV	A*V80704B**	35,000	25,600	17.00	13.00	3610367
	CA*F3743*6A*+TXV	A*VC950453BXA*	34,600	25,300	17.00	13.00	3610336
	CA*F3743*6A*+TXV	A*V90453B**	34,600	25,300	17.00	13.00	3610335
	CA*F3743*6D*+TXV	MBVC1600**-1A*	35,000	25,600	18.00	13.00	4415258
	CA*F3743*6D*+TXV	MBVC2000**-1A*	35,000	25,600	18.00	13.00	4415259
	CA*F3743*6D*+TXV	G*VC951155DXA*	35,000	25,600	18.00	13.00	4415316
	CA*F3743*6D*+TXV	G*VC950905DXA*	35,000	25,600	18.00	13.25	4415315
	CA*F3743*6D*+TXV	G*VC950905CXA*	35,000	25,600	18.00	13.25	4415314
	CA*F3743*6D*+TXV	G*VC950714CXA*	35,000	25,600	17.50	13.00	4415313

See Notes on Page 24.

AHRI PERFORMANCE DATA (CONT.)

OUTDOOR UNIT	INDOOR UNITS		COOLING CAPACITY (BTU/H)				ARI #
	COIL & BLOWER UNITS	FURNACE	TOTAL	SENSIBLE	SEER ¹	EER ²	
ASXC18 0361A* (cont.)	CA*F3743*6D*+TXV	G*VC950704CXA*	35,000	25,600	17.50	13.00	4415312
	CA*F3743*6D*+TXV	A*VC951155DXA*	35,000	25,600	18.00	13.00	4415311
	CA*F3743*6D*+TXV	A*VC950905DXA*	35,000	25,600	18.00	13.25	4415310
	CA*F3743*6D*+TXV	A*VC950905CXA*	35,000	25,600	18.00	13.25	4415309
	CA*F3743*6D*+TXV	A*VC950714CXA*	35,000	25,600	17.50	13.00	4415308
	CA*F3743*6D*+TXV	A*VC950704CXA*	35,000	25,600	17.50	13.00	4415307
	CA*F3743*6D*+TXV	A*VC90905DXA*	35,000	25,600	18.00	13.25	4415306
	CA*F3743*6D*+TXV	A*VC90704CXA*	35,000	25,600	17.50	13.00	4415305
	CA*F3743*6D*+TXV	A*VC81155CXA*	35,000	25,600	17.00	13.00	4415304
	CA*F3743*6D*+TXV	A*VC80905CXA*	35,000	25,600	17.00	13.00	4415303
	CA*F3743*6D*+TXV	A*VC80704BXA*	35,000	25,600	17.00	13.00	4415302
	CA*F4860*6B*+TXV	MBE2000**-1B*	36,000	26,300	19.00	13.50	3610656
	CA*F4860*6B*+TXV	MBVC2000**-1A*	36,000	26,300	19.00	13.50	3610624
	CA*F4860*6B*+TXV	G*VC950915DXA*	35,000	25,600	17.50	13.00	4594841
	CA*F4860*6B*+TXV	A*VC950905CXA*	35,000	25,600	17.50	13.00	4200722
	CA*F4860*6B*+TXV	A*VC950915DXA*	35,000	25,600	17.50	13.00	4200057
	CA*F4860*6B*+TXV	A*VC950905DXA*	35,000	25,600	17.50	13.00	3610386
	CA*F4860*6B*+TXV	A*VC90905DXA*	35,000	25,600	17.50	13.00	3610385
	CA*F4860*6B*+TXV	A*V90905D**	35,000	25,600	17.50	13.00	3610384
	CA*F4860*6D*+TXV	MBVC2000**-1A*	36,000	26,300	19.00	13.50	3881445
	CA*F4860*6D*+TXV	G*VC950915DXA*	35,000	25,600	17.50	13.00	4594842
	CA*F4860*6D*+TXV	A*VC950905CXA*	35,000	25,600	17.50	13.00	4200724
	CA*F4860*6D*+TXV	A*VC950915DXA*	35,000	25,600	17.50	13.00	4200059
	CA*F4860*6D*+TXV	A*VC950905DXA*	35,000	25,600	17.50	13.00	3881448
	CA*F4860*6D*+TXV	A*VC90905DXA*	35,000	25,600	17.50	13.00	3881447
	CA*F4860*6D*+TXV	A*V90905DX**	35,000	25,600	17.50	13.00	3881446
	CA*F4961*6A*+TXV	MBE2000**-1B*	36,000	26,300	19.00	13.50	3610657
	CA*F4961*6A*+TXV	MBVC2000**-1A*	36,000	26,300	19.00	13.50	3610625
	CA*F4961*6A*+TXV	G*VC950915DXA*	35,000	25,600	18.00	13.25	4594843
	CA*F4961*6A*+TXV	A*VC950714CXA*	35,000	25,600	17.50	13.30	4202544
	CA*F4961*6A*+TXV	A*VC950905CXA*	35,000	25,600	18.00	13.25	4200725
	CA*F4961*6A*+TXV	A*VC950915DXA*	35,000	25,600	18.00	13.25	4200061
	CA*F4961*6A*+TXV	A*VC81155CXA*	36,000	26,300	18.00	13.70	3642611
	CA*F4961*6A*+TXV	A*VC80905CXA*	36,000	26,300	18.00	13.70	3629978
	CA*F4961*6A*+TXV	A*VC80704BXA*	36,000	26,300	17.50	13.20	3629972
	CA*F4961*6A*+TXV	A*VC951155DXA*	36,000	26,300	18.30	13.25	3610442
	CA*F4961*6A*+TXV	A*V91155D**	36,000	26,300	18.30	13.25	3610441
	CA*F4961*6A*+TXV	A*V81155C**	36,000	26,300	18.00	13.70	3610440
	CA*F4961*6A*+TXV	A*V80905C**	36,000	26,300	18.00	13.70	3610439
	CA*F4961*6A*+TXV	A*V80704B**	36,000	26,300	17.50	13.20	3610438
	CA*F4961*6A*+TXV	A*VC950905DXA*	35,000	25,600	18.00	13.50	3610394
	CA*F4961*6A*+TXV	A*VC950704CXA*	35,000	25,600	17.50	13.30	3610393

See Notes on Page 24.

AHRI PERFORMANCE DATA (CONT.)

OUTDOOR UNIT	INDOOR UNITS		COOLING CAPACITY (BTU/H)				ARI #
	COIL & BLOWER UNITS	FURNACE	TOTAL	SENSIBLE	SEER ¹	EER ²	
ASXC18 0361A* (cont.)	CA*F4961*6A*+TXV	A*VC950453BXA*	35,000	25,600	17.00	13.00	3610392
	CA*F4961*6A*+TXV	A*VC90905DXA*	35,000	25,600	18.00	13.50	3610391
	CA*F4961*6A*+TXV	A*VC90704CXA*	35,000	25,600	17.50	13.30	3610390
	CA*F4961*6A*+TXV	A*V90905D**	35,000	25,600	18.00	13.50	3610389
	CA*F4961*6A*+TXV	A*V90704C**	35,000	25,600	17.50	13.30	3610388
	CA*F4961*6A*+TXV	A*V90453B**	35,000	25,600	17.00	13.00	3610387
	CA*F4961*6D*+TXV	MBVC2000**-1A*	36,000	26,300	19.00	13.50	4431458
	CA*F4961*6D*+TXV	A*VC951155DXA*	36,000	26,300	18.30	13.25	4431471
	CA*F4961*6D*+TXV	A*VC950905DXA*	35,000	25,600	18.00	13.50	4431470
	CA*F4961*6D*+TXV	A*VC950905CXA*	35,000	25,600	18.00	13.25	4431469
	CA*F4961*6D*+TXV	A*VC950714CXA*	35,000	25,600	17.50	13.30	4431468
	CA*F4961*6D*+TXV	A*VC950704CXA*	35,000	25,600	17.50	13.30	4431467
	CA*F4961*6D*+TXV	A*VC950453BXA*	35,000	25,600	17.00	13.00	4431466
	CA*F4961*6D*+TXV	A*VC90905DXA*	35,000	25,600	18.00	13.50	4431465
	CA*F4961*6D*+TXV	A*VC90704CXA*	35,000	25,600	17.50	13.30	4431464
	CA*F4961*6D*+TXV	A*VC81155CXA*	36,000	26,300	18.00	13.70	4431463
	CA*F4961*6D*+TXV	A*VC80905CXA*	36,000	26,300	18.00	13.70	4431462
	CA*F4961*6D*+TXV	A*VC80704BXA*	36,000	26,300	17.50	13.20	4431461
	CHPF3642C6C*+TXV	MBE1600**-1B*	35,000	25,600	18.00	13.00	3610395
	CHPF3642C6C*+TXV	MBVC1600**-1A*	35,000	25,600	18.00	13.00	3610626
	CHPF3642C6C*+TXV	A*VC950714CXA*	35,000	25,600	17.50	13.00	4202545
	CHPF3642C6C*+TXV	A*VC950704CXA*	35,000	25,600	17.50	13.00	3610398
	CHPF3642C6C*+TXV	A*VC90704CXA*	35,000	25,600	17.50	13.00	3610397
	CHPF3642C6C*+TXV	A*V90704C**	35,000	25,600	17.50	13.00	3610396
	CHPF3642D6C*+TXV	MBE2000**-1B*	35,000	25,600	18.00	13.00	3610399
	CHPF3642D6C*+TXV	MBVC2000**-1A*	35,000	25,600	18.00	13.00	3610627
	CHPF3642D6C*+TXV	G*VC950915DXA*	35,000	25,600	18.00	13.25	4594844
	CHPF3642D6C*+TXV	A*VC950905CXA*	35,000	25,600	18.00	13.25	4200727
	CHPF3642D6C*+TXV	A*VC950915DXA*	35,000	25,600	18.00	13.25	4200063
	CHPF3642D6C*+TXV	A*VC951155DXA*	35,000	25,600	18.00	13.00	3610404
	CHPF3642D6C*+TXV	A*VC950905DXA*	35,000	25,600	18.00	13.25	3610403
	CHPF3642D6C*+TXV	A*VC90905DXA*	35,000	25,600	18.00	13.25	3610402
	CHPF3642D6C*+TXV	A*V91155D**	35,000	25,600	18.00	13.00	3610401
	CHPF3642D6C*+TXV	A*V90905D**	35,000	25,600	18.00	13.25	3610400
	CHPF3743C6B*+TXV	MBE1600**-1B*	35,000	25,600	18.00	13.00	3610405
	CHPF3743C6B*+TXV	MBVC1600**-1A*	35,000	25,600	18.00	13.00	3610628
	CHPF3743C6B*+TXV	G*VC950915DXA*	35,000	25,600	18.00	13.25	4594845
	CHPF3743C6B*+TXV	A*VC950714CXA*	35,000	25,600	17.50	13.00	4202546
	CHPF3743C6B*+TXV	A*VC950905CXA*	35,000	25,600	18.00	13.25	4200728
	CHPF3743C6B*+TXV	A*VC950915DXA*	35,000	25,600	18.00	13.25	4200065
	CHPF3743C6B*+TXV	A*VC81155CXA*	35,000	25,600	17.00	13.00	3642606
	CHPF3743C6B*+TXV	A*VC80905CXA*	35,000	25,600	17.00	13.00	3629954

See Notes on Page 24.

AHRI PERFORMANCE DATA (CONT.)

OUTDOOR UNIT	INDOOR UNITS		COOLING CAPACITY (BTU/H)				ARI #
	COIL & BLOWER UNITS	FURNACE	TOTAL	SENSIBLE	SEER ¹	EER ²	
ASXC18 0361A* (cont.)	CHPF3743C6B*+TXV	A*VC80704BXA*	35,000	25,600	17.00	13.00	3629943
	CHPF3743C6B*+TXV	A*VC951155DXA*	35,000	25,600	18.00	13.00	3610416
	CHPF3743C6B*+TXV	A*VC950905DXA*	35,000	25,600	18.00	13.25	3610415
	CHPF3743C6B*+TXV	A*VC950704CXA*	35,000	25,600	17.50	13.00	3610414
	CHPF3743C6B*+TXV	A*VC90905DXA*	35,000	25,600	18.00	13.25	3610413
	CHPF3743C6B*+TXV	A*VC90704CXA*	35,000	25,600	17.50	13.00	3610412
	CHPF3743C6B*+TXV	A*V91155D**	35,000	25,600	18.00	13.00	3610411
	CHPF3743C6B*+TXV	A*V90905D**	35,000	25,600	18.00	13.25	3610410
	CHPF3743C6B*+TXV	A*V90704C**	35,000	25,600	17.50	13.00	3610409
	CHPF3743C6B*+TXV	A*V81155C**	35,000	25,600	17.00	13.00	3610408
	CHPF3743C6B*+TXV	A*V80905C**	35,000	25,600	17.00	13.00	3610407
	CHPF3743C6B*+TXV	A*V80704B**	35,000	25,600	17.00	13.00	3610406
	CHPF3743C6B*+TXV	A*VC950453BXA*	34,600	25,300	17.00	13.00	3610338
	CHPF3743C6B*+TXV	A*V90453B**	34,600	25,300	17.00	13.00	3610337
	CHPF3743D6B*+TXV	MBE2000**-1B*	35,000	25,600	18.00	13.00	3610417
	CHPF3743D6B*+TXV	MBVC2000**-1A*	35,000	25,600	18.00	13.00	3610629
	CHPF3743D6B*+TXV	G*VC950915DXA*	35,000	25,600	18.00	13.25	4594846
	CHPF3743D6B*+TXV	A*VC950714CXA*	34,600	25,300	17.00	13.00	4202539
	CHPF3743D6B*+TXV	A*VC950905CXA*	35,000	25,600	18.00	13.25	4200730
	CHPF3743D6B*+TXV	A*VC950915DXA*	35,000	25,600	18.00	13.25	4200067
	CHPF3743D6B*+TXV	A*VC81155CXA*	35,000	25,600	17.00	13.00	3642607
	CHPF3743D6B*+TXV	A*VC80905CXA*	35,000	25,600	17.00	13.00	3629955
	CHPF3743D6B*+TXV	A*VC80704BXA*	35,000	25,600	17.00	13.00	3629944
	CHPF3743D6B*+TXV	A*VC951155DXA*	35,000	25,600	18.00	13.00	3610425
	CHPF3743D6B*+TXV	A*VC950905DXA*	35,000	25,600	18.00	13.25	3610424
	CHPF3743D6B*+TXV	A*VC90905DXA*	35,000	25,600	18.00	13.25	3610423
	CHPF3743D6B*+TXV	A*V91155D**	35,000	25,600	18.00	13.00	3610422
	CHPF3743D6B*+TXV	A*V90905D**	35,000	25,600	18.00	13.25	3610421
	CHPF3743D6B*+TXV	A*V81155C**	35,000	25,600	17.00	13.00	3610420
	CHPF3743D6B*+TXV	A*V80905C**	35,000	25,600	17.00	13.00	3610419
	CHPF3743D6B*+TXV	A*V80704B**	35,000	25,600	17.00	13.00	3610418
	CHPF3743D6B*+TXV	A*VC950704CXA*	34,600	25,300	17.00	13.00	3610343
	CHPF3743D6B*+TXV	A*VC950453BXA*	34,600	25,300	17.00	13.00	3610342
	CHPF3743D6B*+TXV	A*VC90704CXA*	34,600	25,300	17.00	13.00	3610341
	CHPF3743D6B*+TXV	A*V90704C**	34,600	25,300	17.00	13.00	3610340
	CHPF3743D6B*+TXV	A*V90453B**	34,600	25,300	17.00	13.00	3610339
	CHPF4860D6D*+TXV	MBE2000**-1B*	35,000	25,600	18.30	13.00	3610426
	CHPF4860D6D*+TXV	MBVC2000**-1A*	35,000	25,600	18.30	13.00	3610630
	CHPF4860D6D*+TXV	G*VC950915DXA*	36,000	26,300	18.00	13.25	4594847
	CHPF4860D6D*+TXV	A*VC950714CXA*	35,000	25,600	17.50	13.30	4202547
	CHPF4860D6D*+TXV	A*VC950905CXA*	36,000	26,300	18.00	13.25	4200732
	CHPF4860D6D*+TXV	A*VC950915DXA*	36,000	26,300	18.00	13.25	4200068

See Notes on Page 24.

AHRI PERFORMANCE DATA (CONT.)

OUTDOOR UNIT	INDOOR UNITS		COOLING CAPACITY (BTU/H)				ARI #
	COIL & BLOWER UNITS	FURNACE	TOTAL	SENSIBLE	SEER ¹	EER ²	
ASXC18 0361A* (cont.)	CHPF4860D6D*+TXV	A*VC81155CXA*	36,000	26,300	18.00	13.70	3642612
	CHPF4860D6D*+TXV	A*VC80905CXA*	36,000	26,300	18.00	13.70	3629979
	CHPF4860D6D*+TXV	A*VC80704BXA*	36,000	26,300	17.50	13.20	3629973
	CHPF4860D6D*+TXV	A*VC950905DXA*	36,000	26,300	18.00	13.25	3610448
	CHPF4860D6D*+TXV	A*VC90905DXA*	36,000	26,300	18.00	13.25	3610447
	CHPF4860D6D*+TXV	A*V90905D**	36,000	26,300	18.00	13.25	3610446
	CHPF4860D6D*+TXV	A*V81155C**	36,000	26,300	18.00	13.70	3610445
	CHPF4860D6D*+TXV	A*V80905C**	36,000	26,300	18.00	13.70	3610444
	CHPF4860D6D*+TXV	A*V80704B**	36,000	26,300	17.50	13.20	3610443
	CHPF4860D6D*+TXV	A*VC951155DXA*	35,000	25,600	18.30	13.25	3610431
	CHPF4860D6D*+TXV	A*VC950704CXA*	35,000	25,600	17.50	13.30	3610430
	CHPF4860D6D*+TXV	A*VC90704CXA*	35,000	25,600	17.50	13.30	3610429
	CHPF4860D6D*+TXV	A*V91155D**	35,000	25,600	18.30	13.25	3610428
	CHPF4860D6D*+TXV	A*V90704C**	35,000	25,600	17.50	13.30	3610427
	CHPF4860D6D*+TXV	A*VC950453BXA*	34,600	25,300	17.00	13.00	3610345
	CHPF4860D6D*+TXV	A*V90453B**	34,600	25,300	17.00	13.00	3610344
	CSCF3642N6C*+TXV	MBE1600**-1B*	34,600	25,300	17.50	13.00	3610651
	CSCF3642N6C*+TXV	MBE2000**-1B*	35,000	25,600	18.00	13.00	3610653
	CSCF3642N6C*+TXV	MBVC1600**-1A*	34,600	25,300	17.50	13.00	3610634
	CSCF3642N6C*+TXV	MBVC2000**-1A*	35,000	25,600	18.00	13.00	3610635
	CSCF3642N6C*+TXV	G*VC950915DXA*	34,600	25,300	17.50	13.00	4594848
	CSCF3642N6C*+TXV	A*VC950714CXA*	34,600	25,300	17.00	13.00	4202540
	CSCF3642N6C*+TXV	A*VC950905CXA*	34,600	25,300	17.50	13.00	4200733
	CSCF3642N6C*+TXV	A*VC950915DXA*	34,600	25,300	17.50	13.00	4200070
	CSCF3642N6C*+TXV	A*VC81155CXA*	34,600	25,300	17.00	13.00	3642592
	CSCF3642N6C*+TXV	A*VC80905CXA*	34,600	25,300	17.00	13.00	3629928
	CSCF3642N6C*+TXV	A*VC80704BXA*	34,600	25,300	17.00	13.00	3629914
	CSCF3642N6C*+TXV	A*VC951155DXA*	34,600	25,300	17.50	13.00	3610358
	CSCF3642N6C*+TXV	A*VC950905DXA*	34,600	25,300	17.50	13.00	3610357
	CSCF3642N6C*+TXV	A*VC950704CXA*	34,600	25,300	17.00	13.00	3610356
	CSCF3642N6C*+TXV	A*VC950453BXA*	34,600	25,300	17.00	13.00	3610355
	CSCF3642N6C*+TXV	A*VC90905DXA*	34,600	25,300	17.50	13.00	3610354
	CSCF3642N6C*+TXV	A*VC90704CXA*	34,600	25,300	17.00	13.00	3610353
	CSCF3642N6C*+TXV	A*V91155D**	34,600	25,300	17.50	13.00	3610352
	CSCF3642N6C*+TXV	A*V90905D**	34,600	25,300	17.50	13.00	3610351
	CSCF3642N6C*+TXV	A*V90704C**	34,600	25,300	17.00	13.00	3610350
	CSCF3642N6C*+TXV	A*V90453B**	34,600	25,300	17.00	13.00	3610349
	CSCF3642N6C*+TXV	A*V81155C**	34,600	25,300	17.00	13.00	3610348
	CSCF3642N6C*+TXV	A*V80905C**	34,600	25,300	17.00	13.00	3610347
	CSCF3642N6C*+TXV	A*V80704B**	34,600	25,300	17.00	13.00	3610346
	CSCF4860N6C*+TXV	MBE1600**-1B*	35,000	25,600	18.00	13.00	3610654
	CSCF4860N6C*+TXV	MBE2000**-1B*	35,000	25,600	18.30	13.00	3610655

See Notes on Page 24.

AHRI PERFORMANCE DATA (CONT.)

OUTDOOR UNIT	INDOOR UNITS		COOLING CAPACITY (BTU/H)				ARI #
	COIL & BLOWER UNITS	FURNACE	TOTAL	SENSIBLE	SEER ¹	EER ²	
ASXC18 0361A* (cont.)	CSCF4860N6C*+TXV	MBVC1600** -1A*	35,000	25,600	18.00	13.00	3610636
	CSCF4860N6C*+TXV	MBVC2000** -1A*	35,000	25,600	18.30	13.00	3610637
	CSCF4860N6C*+TXV	G*VC950915DXA*	35,000	25,600	18.00	13.25	4594849
	CSCF4860N6C*+TXV	A*VC950714CXA*	34,600	25,300	17.50	13.00	4202541
	CSCF4860N6C*+TXV	A*VC950905CXA*	35,000	25,600	18.00	13.25	4200735
	CSCF4860N6C*+TXV	A*VC950915DXA*	35,000	25,600	18.00	13.25	4200072
	CSCF4860N6C*+TXV	A*VC81155CXA*	36,000	26,300	18.00	13.70	3642614
	CSCF4860N6C*+TXV	A*VC80905CXA*	36,000	26,300	18.00	13.70	3629980
	CSCF4860N6C*+TXV	A*VC80704BXA*	36,000	26,300	17.50	13.20	3629974
	CSCF4860N6C*+TXV	A*V81155C**	36,000	26,300	18.00	13.70	3610451
	CSCF4860N6C*+TXV	A*V80905C**	36,000	26,300	18.00	13.70	3610450
	CSCF4860N6C*+TXV	A*V80704B**	36,000	26,300	17.50	13.20	3610449
	CSCF4860N6C*+TXV	A*VC951155DXA*	35,000	25,600	18.30	13.25	3610436
	CSCF4860N6C*+TXV	A*VC950905DXA*	35,000	25,600	18.00	13.25	3610435
	CSCF4860N6C*+TXV	A*VC90905DXA*	35,000	25,600	18.00	13.25	3610434
	CSCF4860N6C*+TXV	A*V91155D**	35,000	25,600	18.30	13.25	3610433
	CSCF4860N6C*+TXV	A*V90905D**	35,000	25,600	18.00	13.25	3610432
	CSCF4860N6C*+TXV	A*VC950704CXA*	34,600	25,300	17.50	13.00	3610363
	CSCF4860N6C*+TXV	A*VC950453BXA*	34,600	25,300	17.00	13.00	3610362
	CSCF4860N6C*+TXV	A*VC90704CXA*	34,600	25,300	17.50	13.00	3610361
	CSCF4860N6C*+TXV	A*V90704C**	34,600	25,300	17.50	13.00	3610360
	CSCF4860N6C*+TXV	A*V90453B**	34,600	25,300	17.00	13.00	3610359
	ASXC18 0481A*	AEPF426016C*+TXV		47,000	35,700	17.5	13.0
AVPTC426014A*			47,000	35,700	17.5	13.0	4431358
CA*F4961*6A*+TXV		G*VC950915DXA*	47,000	35,700	17.5	13.0	4202552
CA*F4961*6A*+TXV		A*VC950915DXA*	47,000	35,700	17.5	13.0	4202551
CA*F4961*6A*+TXV		A*VC950714CXA*	46,000	35,000	17.0	13.0	4202548
CA*F4961*6A*+TXV		A*VC81155CXA*	48,000	36,500	17.0	12.2	3642641
CA*F4961*6A*+TXV		A*VC80905CXA*	48,000	36,500	17.0	13.0	3630036
CA*F4961*6A*+TXV		MBE2000** -1B*	47,500	36,100	18.3	13.3	3610665
CA*F4961*6A*+TXV		MBVC2000** -1A*	47,500	36,100	18.3	13.3	3610640
CA*F4961*6A*+TXV		A*V81155C**	48,000	36,500	17.0	13.0	3610541
CA*F4961*6A*+TXV		A*V80905C**	48,000	36,500	17.0	13.0	3610540
CA*F4961*6A*+TXV		A*VC951155DXA*	47,500	36,100	18.0	13.0	3610534
CA*F4961*6A*+TXV		A*V91155D**	47,500	36,100	18.0	13.0	3610533
CA*F4961*6A*+TXV		G*VC951155DXA*	47,000	35,700	18.0	13.0	3610519
CA*F4961*6A*+TXV		G*VC950905DXA*	47,000	35,700	17.5	13.0	3610518
CA*F4961*6A*+TXV		G*V951155D**	47,000	35,700	18.0	13.0	3610517
CA*F4961*6A*+TXV		G*V950905D**	47,000	35,700	17.5	13.0	3610516
CA*F4961*6A*+TXV		A*VC950905DXA*	47,000	35,700	17.5	13.0	3610515
CA*F4961*6A*+TXV		A*VC90905DXA*	47,000	35,700	17.5	13.0	3610514
CA*F4961*6A*+TXV		A*V90905D**	47,000	35,700	17.5	13.0	3610513

See Notes on Page 24.

AHRI PERFORMANCE DATA (CONT.)

OUTDOOR UNIT	INDOOR UNITS		COOLING CAPACITY (BTU/H)				ARI #
	COIL & BLOWER UNITS	FURNACE	TOTAL	SENSIBLE	SEER ¹	EER ²	
ASXC18 0481A* (cont.)	CA*F4961*6A*+TXV	A*VC950704CXA*	46,000	35,000	17.0	13.0	3610469
	CA*F4961*6A*+TXV	A*VC90704CXA*	46,000	35,000	17.0	13.0	3610468
	CA*F4961*6A*+TXV	A*V90704C**	46,000	35,000	17.0	13.0	3610467
	CA*F4961*6D*+TXV	G*VC951155DXA*	47,000	35,700	18.0	13.0	4431483
	CA*F4961*6D*+TXV	G*VC950915DXA*	47,000	35,700	17.5	13.0	4431482
	CA*F4961*6D*+TXV	G*VC950905DXA*	47,000	35,700	17.5	13.0	4431481
	CA*F4961*6D*+TXV	A*VC951155DXA*	47,500	36,100	18.0	13.0	4431480
	CA*F4961*6D*+TXV	A*VC950915DXA*	47,000	35,700	17.5	13.0	4431479
	CA*F4961*6D*+TXV	A*VC950905DXA*	47,000	35,700	17.5	13.0	4431478
	CA*F4961*6D*+TXV	A*VC950714CXA*	46,000	35,000	17.0	13.0	4431477
	CA*F4961*6D*+TXV	A*VC950704CXA*	46,000	35,000	17.0	13.0	4431476
	CA*F4961*6D*+TXV	A*VC90905DXA*	47,000	35,700	17.5	13.0	4431475
	CA*F4961*6D*+TXV	A*VC90704CXA*	46,000	35,000	17.0	13.0	4431474
	CA*F4961*6D*+TXV	A*VC81155CXA*	48,000	36,500	17.0	12.2	4431473
	CA*F4961*6D*+TXV	A*VC80905CXA*	48,000	36,500	17.0	13.0	4431472
	CA*F4961*6D*+TXV	MBVC2000**-1A*	47,500	36,100	18.3	13.3	4431459
	CHPF4860D6D*+TXV	G*VC950915DXA*	47,000	35,700	16.5	13.0	4594850
	CHPF4860D6D*+TXV	A*VC950714CXA*	46,000	35,000	17.0	13.0	4202549
	CHPF4860D6D*+TXV	A*VC950905CXA*	47,000	35,700	16.5	13.0	4200737
	CHPF4860D6D*+TXV	A*VC950915DXA*	47,000	35,700	16.5	13.0	4200074
	CHPF4860D6D*+TXV	A*VC81155CXA*	48,000	36,500	17.0	12.2	3642642
	CHPF4860D6D*+TXV	A*VC80905CXA*	48,000	36,500	17.0	13.0	3630037
	CHPF4860D6D*+TXV	MBVC2000**-1A*	47,500	36,100	18.3	13.3	3610642
	CHPF4860D6D*+TXV	MBVC1600**-1A*	46,000	35,000	17.0	13.0	3610641
	CHPF4860D6D*+TXV	A*V81155C**	48,000	36,500	17.0	13.0	3610543
	CHPF4860D6D*+TXV	A*V80905C**	48,000	36,500	17.0	13.0	3610542
	CHPF4860D6D*+TXV	A*VC951155DXA*	47,500	36,100	18.0	13.0	3610537
	CHPF4860D6D*+TXV	A*V91155D**	47,500	36,100	18.0	13.0	3610536
	CHPF4860D6D*+TXV	MBE2000**-1B*	47,500	36,100	18.3	13.3	3610535
	CHPF4860D6D*+TXV	A*VC950905DXA*	47,000	35,700	17.5	13.0	3610528
	CHPF4860D6D*+TXV	A*VC90905DXA*	47,000	35,700	17.5	13.0	3610527
	CHPF4860D6D*+TXV	A*V90905D**	47,000	35,700	17.5	13.0	3610526
	CHPF4860D6D*+TXV	A*VC950704CXA*	46,000	35,000	17.0	13.0	3610477
	CHPF4860D6D*+TXV	A*VC90704CXA*	46,000	35,000	17.0	13.0	3610476
	CHPF4860D6D*+TXV	A*V90704C**	46,000	35,000	17.0	13.0	3610475
	CHPF4860D6D*+TXV	MBE1600**-1B*	46,000	35,000	17.0	13.0	3610471
	CSCF4860N6C*+TXV	G*VC950915DXA*	47,000	35,700	16.5	13.0	4594851
	CSCF4860N6C*+TXV	A*VC950714CXA*	46,000	35,000	17.0	13.0	4202550
	CSCF4860N6C*+TXV	A*VC950905CXA*	47,000	35,700	16.5	13.0	4200739
	CSCF4860N6C*+TXV	A*VC950915DXA*	47,000	35,700	16.5	13.0	4200076
	CSCF4860N6C*+TXV	A*VC81155CXA*	48,000	36,500	17.0	12.2	3642643
	CSCF4860N6C*+TXV	A*VC80905CXA*	48,000	36,500	17.0	13.0	3630038

See Notes on Page 24.

AHRI PERFORMANCE DATA (CONT.)

OUTDOOR UNIT	INDOOR UNITS		COOLING CAPACITY (BTU/H)				ARI #
	COIL & BLOWER UNITS	FURNACE	TOTAL	SENSIBLE	SEER ¹	EER ²	
ASXC18 0481A* (cont.)	CSCF4860N6C*+TXV	MBE2000** -1B*	47,500	36,100	18.3	13.3	3610666
	CSCF4860N6C*+TXV	MBVC2000** -1A*	47,500	36,100	18.3	13.3	3610644
	CSCF4860N6C*+TXV	A*V81155C**	48,000	36,500	17.0	13.0	3610545
	CSCF4860N6C*+TXV	A*V80905C**	48,000	36,500	17.0	13.0	3610544
	CSCF4860N6C*+TXV	A*VC951155DXA*	47,500	36,100	18.0	13.0	3610539
	CSCF4860N6C*+TXV	A*V91155D**	47,500	36,100	18.0	13.0	3610538
	CSCF4860N6C*+TXV	A*VC950905DXA*	47,000	35,700	17.5	13.0	3610532
	CSCF4860N6C*+TXV	A*VC90905DXA*	47,000	35,700	17.5	13.0	3610531
	CSCF4860N6C*+TXV	A*V90905D**	47,000	35,700	17.5	13.0	3610530
	CSCF4860N6C*+TXV	A*VC950704CXA*	46,000	35,000	17.0	13.0	3610486
	CSCF4860N6C*+TXV	A*VC90704CXA*	46,000	35,000	17.0	13.0	3610485
	CSCF4860N6C*+TXV	A*V90704C**	46,000	35,000	17.0	13.0	3610484
ASXC18 0601A*	AEPF426016C*+TXV		58,000	42,300	16.0	11.8	3610588
	AVPTC426014A*		58,000	42,300	16.0	11.8	4431359
	CA*F4961*6A*+TXV	MBE2000** -1B*	58,000	42,300	17.0	12.0	3610670
	CA*F4961*6A*+TXV	MBVC2000** -1A*	58,000	42,300	17.0	12.0	3610646
	CA*F4961*6A*+TXV	G*VC950905CXA*	58,000	42,300	16.0	11.5	4200743
	CA*F4961*6A*+TXV	A*VC950905CXA*	58,000	42,300	16.0	11.5	4200741
	CA*F4961*6A*+TXV	G*VC950915DXA*	58,000	42,300	16.0	11.5	4200080
	CA*F4961*6A*+TXV	A*VC950915DXA*	58,000	42,300	16.0	11.5	4200078
	CA*F4961*6A*+TXV	A*VC81155CXA*	56,000	40,900	15.8	11.2	3642663
	CA*F4961*6A*+TXV	A*VC80905CXA*	56,000	40,900	15.8	11.2	3642649
	CA*F4961*6A*+TXV	G*VC951155DXA*	58,000	42,300	16.0	11.5	3610597
	CA*F4961*6A*+TXV	G*VC950905DXA*	58,000	42,300	16.0	11.5	3610596
	CA*F4961*6A*+TXV	G*V951155D**	58,000	42,300	16.0	11.5	3610595
	CA*F4961*6A*+TXV	G*V950905D**	58,000	42,300	16.0	11.5	3610594
	CA*F4961*6A*+TXV	A*VC951155DXA*	58,000	42,300	16.0	11.5	3610593
	CA*F4961*6A*+TXV	A*VC950905DXA*	58,000	42,300	16.0	11.5	3610592
	CA*F4961*6A*+TXV	A*VC90905DXA*	58,000	42,300	16.0	11.5	3610591
	CA*F4961*6A*+TXV	A*V91155D**	58,000	42,300	16.0	11.5	3610590
	CA*F4961*6A*+TXV	A*V90905D**	58,000	42,300	16.0	11.5	3610589
	CA*F4961*6A*+TXV	A*V81155C**	56,000	40,900	15.8	11.2	3610549
	CA*F4961*6A*+TXV	A*V80905C**	56,000	40,900	15.8	11.2	3610548
	CA*F4961*6D*+TXV	MBVC2000** -1A*	58,000	42,300	17.0	12.0	4431460
	CA*F4961*6D*+TXV	G*VC951155DXA*	58,000	42,300	16.0	11.5	4431492
	CA*F4961*6D*+TXV	G*VC950905DXA*	58,000	42,300	16.0	11.5	4431491
	CA*F4961*6D*+TXV	G*VC950905CXA*	58,000	42,300	16.0	11.5	4431490
	CA*F4961*6D*+TXV	A*VC951155DXA*	58,000	42,300	16.0	11.5	4431489
	CA*F4961*6D*+TXV	A*VC950905DXA*	58,000	42,300	16.0	11.5	4431488
	CA*F4961*6D*+TXV	A*VC950905CXA*	58,000	42,300	16.0	11.5	4431487
	CA*F4961*6D*+TXV	A*VC90905DXA*	58,000	42,300	16.0	11.5	4431486
	CA*F4961*6D*+TXV	A*VC81155CXA*	56,000	40,900	15.8	11.2	4431485

See Notes on Page 24.

AHRI PERFORMANCE DATA (CONT.)

OUTDOOR UNIT	INDOOR UNITS		COOLING CAPACITY (BTU/H)				ARI #
	COIL & BLOWER UNITS	FURNACE	TOTAL	SENSIBLE	SEER ¹	EER ²	
ASXC18 0601A* (cont.)	CA*F4961*6D*+TXV	A*VC80905CXA*	56,000	40,900	15.8	11.2	4431484
	CHPF4860D6D*+TXV	MBE2000** -1B*	58,000	42,300	17.0	12.0	3610598
	CHPF4860D6D*+TXV	MBVC2000** -1A*	58,000	42,300	17.0	12.0	3610647
	CHPF4860D6D*+TXV	G*VC950915DXA*	58,000	42,300	16.0	11.5	4594852
	CHPF4860D6D*+TXV	A*VC950905CXA*	58,000	42,300	16.0	11.5	4200744
	CHPF4860D6D*+TXV	A*VC950915DXA*	58,000	42,300	16.0	11.5	4200081
	CHPF4860D6D*+TXV	A*VC81155CXA*	56,000	40,900	15.8	11.2	3642664
	CHPF4860D6D*+TXV	A*VC80905CXA*	56,000	40,900	15.8	11.2	3642650
	CHPF4860D6D*+TXV	A*VC951155DXA*	58,000	42,300	16.0	11.8	3610603
	CHPF4860D6D*+TXV	A*VC950905DXA*	58,000	42,300	16.0	11.5	3610602
	CHPF4860D6D*+TXV	A*VC90905DXA*	58,000	42,300	16.0	11.5	3610601
	CHPF4860D6D*+TXV	A*V91155D**	58,000	42,300	16.0	11.8	3610600
	CHPF4860D6D*+TXV	A*V90905D**	58,000	42,300	16.0	11.5	3610599
	CHPF4860D6D*+TXV	A*V81155C**	56,000	40,900	15.8	11.2	3610555
	CHPF4860D6D*+TXV	A*V80905C**	56,000	40,900	15.8	11.2	3610554
	CSCF4860N6C*+TXV	MBE2000** -1B*	58,000	42,300	16.5	11.8	3610671
	CSCF4860N6C*+TXV	MBVC2000** -1A*	58,000	42,300	16.5	11.8	3610649
	CSCF4860N6C*+TXV	G*VC950915DXA*	58,000	42,300	16.0	11.5	4594853
	CSCF4860N6C*+TXV	A*VC950905CXA*	58,000	42,300	16.0	11.5	4200746
	CSCF4860N6C*+TXV	A*VC950915DXA*	58,000	42,300	16.0	11.5	4200083
	CSCF4860N6C*+TXV	A*VC81155CXA*	56,000	40,900	15.8	11.2	3642665
	CSCF4860N6C*+TXV	A*VC80905CXA*	56,000	40,900	15.8	11.2	3642651
	CSCF4860N6C*+TXV	A*VC951155DXA*	58,000	42,300	16.0	11.8	3610608
	CSCF4860N6C*+TXV	A*VC950905DXA*	58,000	42,300	16.0	11.5	3610607
	CSCF4860N6C*+TXV	A*VC90905DXA*	58,000	42,300	16.0	11.5	3610606
	CSCF4860N6C*+TXV	A*V91155D**	58,000	42,300	16.0	11.8	3610605
	CSCF4860N6C*+TXV	A*V90905D**	58,000	42,300	16.0	11.5	3610604
	CSCF4860N6C*+TXV	A*V81155C**	56,000	40,900	15.8	11.2	3610558
	CSCF4860N6C*+TXV	A*V80905C**	56,000	40,900	15.8	11.2	3610557

¹ Seasonal Energy Efficiency Ratio; Certified per AHRI 210/240 @ 80°F/ 67°F/ 95°F

² Energy Efficiency Ratio @ 80°F/ 67°F/ 95°F

NOTES:

- Always check the S&R plate for electrical data on the unit being installed.
- When matching the outdoor unit to the indoor unit, use the piston supplied with the outdoor unit or that specified on the piston kit chart supplied with the indoor unit.
- EEP - Order from Service Dept. Part No. B13707-38 or new Solid State Board B13707-35S. Part No. B13707-38 is not interchangeable with B13707-35S. The Goodman Gas Furnace contains the EEP cooling time delay

DIMENSIONS

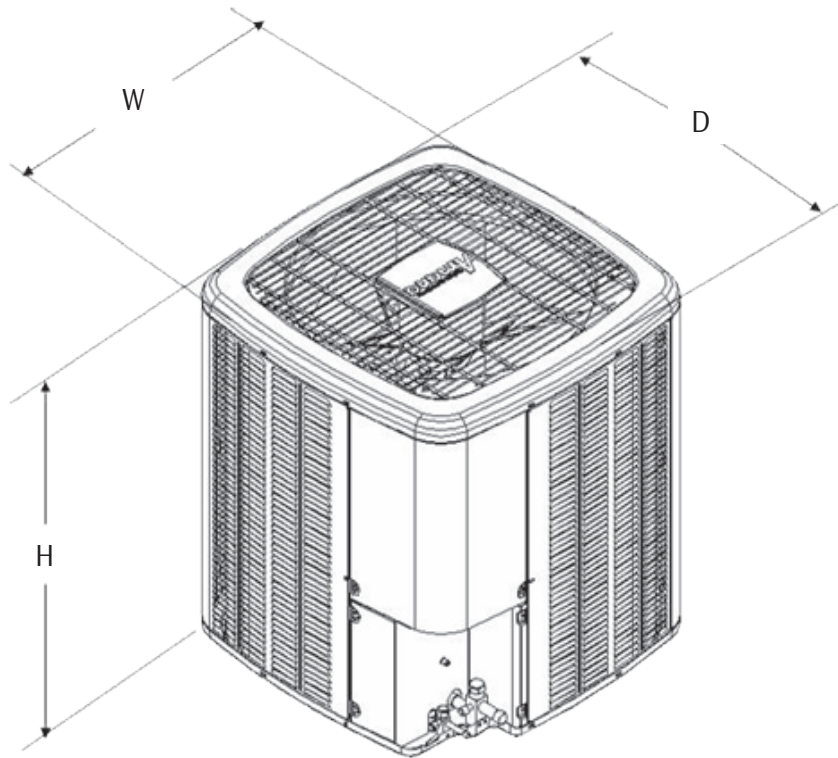

MODEL	W	D	H
ASXC180361A*	35½	35½	38¾
ASXC180481A*	35½	35½	38¾
ASXC180601A*	35½	35½	38¾

WIRING DIAGRAM

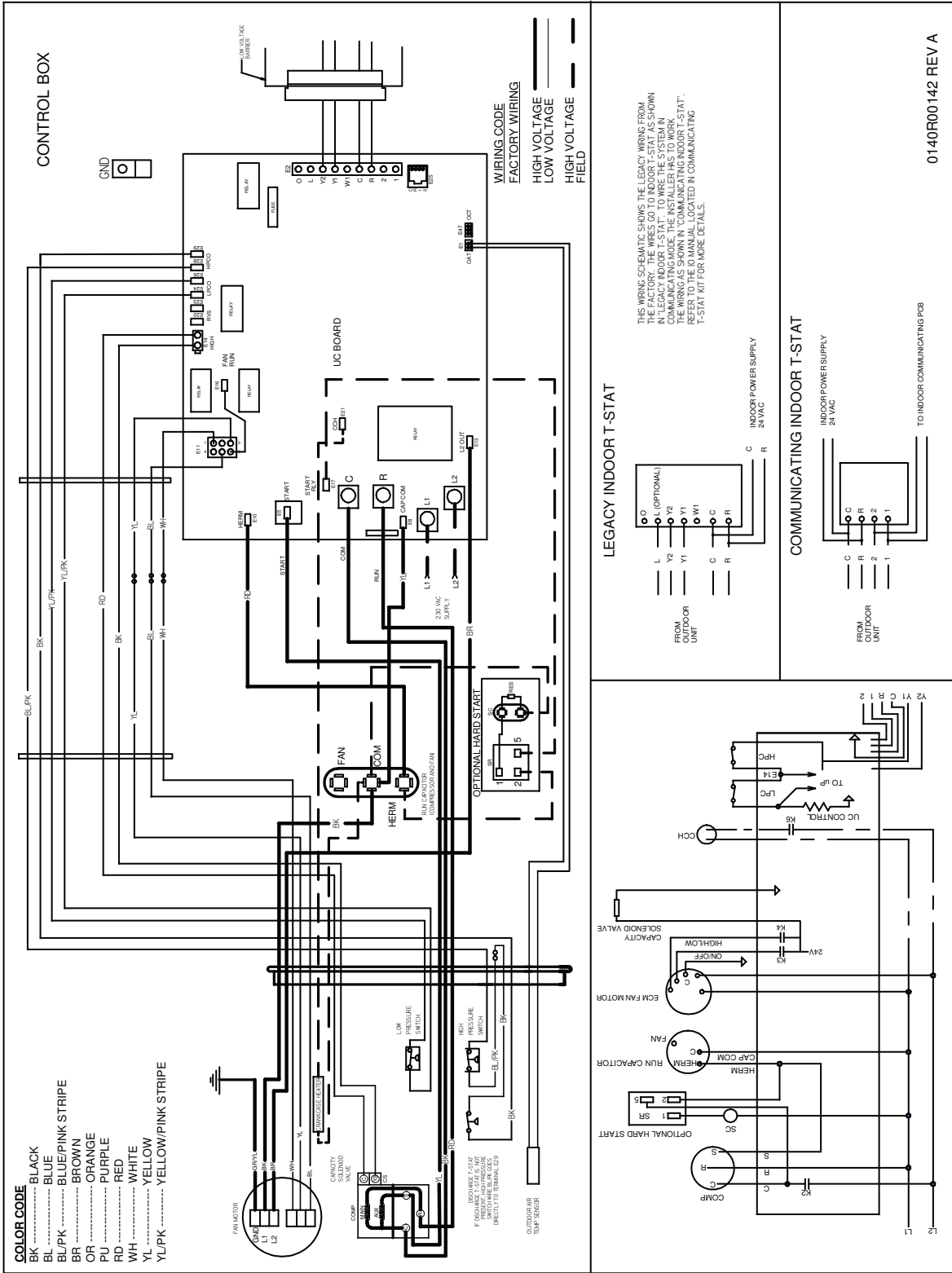

High Voltage: Disconnect all power before servicing or installing this unit. Multiple power sources may be present. Failure to do so may cause property damage, personal injury, or death.

WARNING

Wiring is subject to change. Always refer to the wiring diagram or the unit for the most up-to-date wiring.

ACCESSORIES

MODEL	DESCRIPTION	ASXC18 036	ASXC18 048	ASXC18 060
ABK-20	Anchor Bracket Kit [°]	X	X	X
ASC-01	Anti-Short Cycle Kit	X	X	X
B1141643 ¹	24V Transformer	X	X	X
CSR-U-1	Hard-start Kit	X		
CSR-U-2	Hard-start Kit	X	X	X
CSR-U-3	Hard-start Kit		X	X
FSK01A ²	Freeze Protection Kit	X	X	X
LSK02A	Liquid Line Solenoid Valve	X	X	X
OT18-60A ³	Outdoor Thermostat/Lockout Thermostat	X	X	X
TX2N4 ⁴	TXV Kit			
TX2N4A ⁴	TXV Kit			
TX3N4 ⁴	TXV Kit	X		
TX5N4	TXV Kit		X	X

[°] Contains 20 brackets; four brackets needed to anchor unit to pad

¹ This component is included in the CTK01AA communicating thermostat kit.

² Installed on indoor coil

³ Available in 24V legacy mode only. This feature is integrated in the communicating mode.

⁴ Condensing units and heat pumps with reciprocating compressors require the use of start-assist components when used in conjunction with an indoor coil using a non-bleed thermal expansion valve refrigerant metering device or liquid line solenoid kit. The TXV should always be sized based on the tonnage of the outdoor unit.

NOTES



Amana® is a trademark of Maytag Corporation or its related companies and used under license to Goodman Company, L.P. All rights reserved. Our continuing commitment to quality products may mean a change in specifications without notice. © 2011 • Goodman Company, L.P. • Houston, Texas • Printed in the USA.

