



ASXC16

SPLIT SYSTEM AIR CONDITIONER

COOLING CAPACITY
24,000 - 57,000 BTU/H

UP TO 16 SEER

R-410A

Standard Features

- R-410A chlorine-free refrigerant
- Two-Stage Copeland® UltraTech scroll compressor
- High-density foam compressor sound blanket
- ComfortNet™ Communications System compatible
- Expanded ComfortAlert™ diagnostics built in
- Set-up capable with two low-voltage wires to outdoor unit
- Diagnostic indicator lights and storage of six fault codes
- Color-coded terminal strip for non-communicating set-up
- High- and low-pressure switches
- Fully charged for 15' of tubing length
- Factory-installed filter dryer
- Coil and ambient temperature sensors
- Two-speed, quiet condenser fan motor
- Sweat connection service valves with easy access to gauge ports
- AHRI Certified; ETL Listed

Cabinet Features

- Amana® brand sound control top design
- Wire fan discharge grille
- Steel louver coil guard
- Baked-on powder paint finish
- Rust-resistant coated screws
- Compact footprint
- Top and side maintenance access
- Single-panel access to controls with space provided for field-installed accessories
- When properly anchored, meets 2001 Florida Building Code unit integrity requirements for hurricane-type winds (Anchor bracket kits available.)



Contents

Nomenclature	2
Product Specifications	3
Expanded Cooling Data	4
AHRI Performance Data	28
Dimensions	46
Wiring Diagram	47
Accessories	48



* Complete warranty details available from your local dealer or at www.amana-hac.com. To receive the Lifetime Unit Replacement Limited Warranty (good for as long as you own your home) and 10-Year Parts Limited Warranty, online registration must be completed within 60 days of installation. Online registration is not required in California or Québec.

SPECIFICATIONS

	ASXC16 0241B*	ASXC16 0361B*	ASXC16 0481A*	ASXC16 0481B*	ASXC16 0601A*	ASXC16 0601B*
COOLING CAPACITY						
Nominal Cooling (BTU/h)	24,000	36,000	48,000	48,000	60,000	60,000
Decibels	71	73	74	74	75	75
COMPRESSOR						
RLA	10.3	16.7	21.2	21.2	25.6	25.6
LRA	52.0	82.0	96.0	96.0	118.0	118.0
CONDENSER FAN MOTOR						
Horsepower (RPM)	1/6	1/6	1/6	1/6	1/6	1/6
FLA	1.1	0.9	1.0	1.0	1.0	1.0
REFRIGERATION SYSTEM						
Refrigerant Line Size ¹						
Liquid Line Size ("O.D.)	3/8"	3/8"	3/8"	3/8"	3/8"	3/8"
Suction Line Size ("O.D.)	3/4"	7/8"	1 1/8"	1 1/8"	1 1/8"	1 1/8"
Refrigerant Connection Size						
Liquid Valve Size ("O.D.)	3/8"	3/8"	3/8"	3/8"	3/8"	3/8"
Suction Valve Size ("O.D.)	3/4"	3/4"	7/8"	7/8"	7/8"	7/8"
Valve Connection Type	Sweat	Sweat	Sweat	Sweat	Sweat	Sweat
Refrigerant Charge	97	107	199	132	194	197
ELECTRICAL DATA						
Voltage-Hz-Phase	208/230-60-1	208/230-60-1	208/230-60-1	208/230-60-1	208/230-60-1	208/230-60-1
Minimum Circuit Ampacity ²	14.0	21.8	27.5	27.5	33.0	33.0
Max. Overcurrent Protection ³	20	35	45	45	50	50
Min / Max Volts	197/253	197/253	197/253	197/253	197/253	197/253
Power Supply	1/2" or 3/4"	1/2" or 3/4"	1/2" or 3/4"	1/2" or 3/4"	1/2" or 3/4"	1/2" or 3/4"
SHIP WEIGHT (LBS)	198	206	282	236	296	296

¹ Tested and rated in accordance with AHRI Standard 210/240

² Wire size should be determined in accordance with National Electrical Codes; extensive wire runs will require larger wire sizes

³ Must use time-delay fuses or HACR-type circuit breakers of the same size as noted.

NOTES

- Always check the S&R plate for electrical data on the unit being installed.
- Installer will need to supply 3/8" to 1 1/8" adapters for suction line connections.
- Unit is charged with refrigerant for 15' of 3/8" liquid line. System charge must be adjusted per Installation Instructions Final Charge Procedure.
- Installation of these units requires the specified TXV Kit to be installed on the indoor coil. THE SPECIFIED TXV IS DETERMINED BY THE OUTDOOR UNIT NOT THE INDOOR COIL.

EXPANDED COOLING DATA — ASXC160241**/ CA*F3636C6C*+TXV/ MBVC1200** Low Stage

IDB	AIRFLOW	OUTDOOR AMBIENT TEMPERATURE																								
		65°F				75°F				85°F				95°F				105°F				115°F				
		59	63	67	71	59	63	67	71	59	63	67	71	59	63	67	71	59	63	67	71	59	63	67	71	
70	675	MBh	18.0	18.7	20.4	-	17.6	18.2	20.0	-	17.2	17.8	19.5	-	16.7	17.4	19.0	-	15.9	16.5	18.1	-	14.7	15.3	16.7	-
		S/T	0.75	0.63	0.43	-	0.78	0.65	0.45	-	0.80	0.66	0.46	-	0.82	0.69	0.48	-	0.85	0.71	0.49	-	0.86	0.72	0.50	-
	600	ΔT	1.8	1.6	1.2	-	1.9	1.6	1.2	-	1.9	1.6	1.2	-	1.9	1.6	1.2	-	1.8	1.6	1.2	-	1.7	1.5	1.1	-
		kW	1.10	1.12	1.16	-	1.19	1.21	1.25	-	1.26	1.29	1.34	-	1.33	1.37	1.41	-	1.39	1.43	1.48	-	1.44	1.48	1.53	-
	525	Amps	4.5	4.6	4.7	-	4.8	4.9	5.1	-	5.2	5.3	5.5	-	5.6	5.7	5.9	-	5.9	6.1	6.3	-	6.3	6.4	6.6	-
		HI PR	228	245	248	-	258	277	281	-	293	315	319	-	334	359	364	-	375	404	409	-	420	452	458	-
	675	Lo PR	122	125	137	-	125	129	141	-	129	133	146	-	133	137	150	-	135	140	153	-	139	143	156	-
		MBh	17.5	18.1	19.8	-	17.1	17.7	19.4	-	16.7	17.3	18.9	-	16.3	16.8	18.5	-	15.4	16.0	17.5	-	14.3	14.8	16.2	-
	600	S/T	0.71	0.60	0.41	-	0.74	0.62	0.43	-	0.76	0.63	0.44	-	0.78	0.65	0.45	-	0.81	0.68	0.47	-	0.82	0.68	0.47	-
		ΔT	1.9	1.7	1.3	-	1.9	1.7	1.3	-	1.9	1.7	1.3	-	2.0	1.7	1.3	-	1.9	1.7	1.3	-	1.8	1.6	1.2	-
	525	kW	1.09	1.11	1.15	-	1.18	1.20	1.24	-	1.25	1.28	1.33	-	1.32	1.35	1.40	-	1.38	1.41	1.46	-	1.43	1.47	1.52	-
		Amps	4.4	4.5	4.7	-	4.8	4.9	5.0	-	5.2	5.3	5.5	-	5.5	5.6	5.8	-	5.9	6.0	6.2	-	6.2	6.4	6.6	-
675	HI PR	226	243	246	-	255	274	278	-	290	312	316	-	330	355	360	-	372	400	405	-	416	447	454	-	
	Lo PR	120	124	136	-	124	128	140	-	128	132	144	-	132	136	148	-	134	138	151	-	137	142	155	-	
600	MBh	16.1	16.7	18.3	-	15.8	16.3	17.9	-	15.4	15.9	17.5	-	15.0	15.6	17.0	-	14.3	14.8	16.2	-	13.2	13.7	15.0	-	
	S/T	0.69	0.58	0.40	-	0.71	0.60	0.41	-	0.73	0.61	0.42	-	0.76	0.63	0.44	-	0.78	0.65	0.45	-	0.79	0.66	0.46	-	
525	ΔT	1.9	1.7	1.3	-	2.0	1.7	1.3	-	2.0	1.7	1.3	-	2.0	1.7	1.3	-	2.0	1.7	1.3	-	1.8	1.6	1.2	-	
	kW	1.08	1.10	1.14	-	1.17	1.19	1.23	-	1.24	1.27	1.31	-	1.31	1.34	1.39	-	1.37	1.40	1.45	-	1.42	1.45	1.50	-	
675	Amps	4.4	4.5	4.6	-	4.7	4.8	5.0	-	5.1	5.3	5.4	-	5.5	5.6	5.8	-	5.8	6.0	6.2	-	6.2	6.3	6.5	-	
	HI PR	223	240	244	-	252	271	275	-	287	309	313	-	327	352	357	-	368	396	401	-	412	443	449	-	
600	Lo PR	119	123	134	-	123	127	138	-	127	131	143	-	130	134	147	-	133	137	150	-	136	140	153	-	

75	675	MBh	18.3	18.8	20.4	21.9	17.9	18.4	19.9	21.4	17.5	18.0	19.4	20.9	17.0	17.5	19.0	20.4	16.7	17.2	18.0	19.3	15.0	15.4	16.7	17.9
		S/T	0.85	0.76	0.58	0.37	0.88	0.79	0.60	0.38	0.90	0.81	0.61	0.39	0.93	0.84	0.63	0.41	0.97	0.87	0.66	0.42	0.98	0.87	0.66	0.43
	600	ΔT	2.1	2.0	1.6	1.1	2.1	2.0	1.6	1.1	2.2	2.0	1.6	1.1	2.2	2.0	1.6	1.1	2.1	2.0	1.6	1.1	2.0	1.8	1.5	1.0
		kW	1.10	1.12	1.16	1.20	1.19	1.21	1.25	1.30	1.26	1.29	1.34	1.38	1.33	1.37	1.41	1.46	1.39	1.43	1.48	1.53	1.44	1.48	1.53	1.58
	525	Amps	4.5	4.6	4.7	4.9	4.8	4.9	5.1	5.3	5.2	5.3	5.5	5.7	5.6	5.7	5.9	6.1	5.9	6.1	6.3	6.5	6.3	6.4	6.6	6.9
		HI PR	228	245	248	254	258	277	281	287	293	315	319	326	334	359	364	372	375	404	409	418	420	452	458	468
	675	Lo PR	122	125	137	146	125	129	141	150	129	133	146	155	133	137	150	159	135	140	153	162	139	143	156	166
		MBh	17.8	18.3	19.8	21.3	17.4	17.9	19.3	20.8	16.9	17.4	18.9	20.3	16.5	17.0	18.4	19.8	15.7	16.2	17.5	18.8	14.5	15.0	16.2	17.4
	600	S/T	0.81	0.73	0.55	0.35	0.84	0.75	0.57	0.37	0.86	0.77	0.58	0.38	0.89	0.80	0.60	0.39	0.92	0.83	0.63	0.40	0.93	0.83	0.63	0.41
		ΔT	2.2	2.0	1.7	1.2	2.2	2.1	1.7	1.2	2.2	2.1	1.7	1.2	2.3	2.1	1.7	1.2	2.2	2.0	1.7	1.2	2.1	1.9	1.6	1.1
	525	kW	1.09	1.11	1.15	1.19	1.18	1.20	1.24	1.29	1.25	1.28	1.33	1.37	1.32	1.35	1.40	1.45	1.38	1.41	1.46	1.51	1.43	1.47	1.52	1.57
		Amps	4.4	4.5	4.7	4.8	4.8	4.9	5.0	5.2	5.2	5.3	5.5	5.7	5.5	5.7	5.8	6.1	5.9	6.0	6.2	6.4	6.2	6.4	6.6	6.8
675	HI PR	226	243	246	251	255	274	278	284	290	312	316	323	330	355	360	368	372	400	405	414	416	447	454	464	
	Lo PR	120	124	136	144	124	128	140	149	128	132	144	154	132	136	148	158	134	138	151	161	137	142	155	165	
600	MBh	16.4	16.9	18.3	19.6	16.0	16.5	17.9	19.2	15.6	16.1	17.4	18.7	15.3	15.7	17.0	18.2	14.5	14.9	16.2	17.3	13.4	13.8	15.0	16.1	
	S/T	0.78	0.70	0.53	0.34	0.81	0.73	0.55	0.35	0.83	0.74	0.56	0.36	0.86	0.77	0.58	0.37	0.89	0.80	0.60	0.39	0.90	0.80	0.61	0.39	
525	ΔT	2.2	2.1	1.7	1.2	2.3	2.1	1.7	1.2	2.3	2.1	1.7	1.2	2.3	2.1	1.7	1.2	2.3	2.1	1.7	1.2	2.1	1.9	1.6	1.1	
	kW	1.08	1.10	1.14	1.18	1.17	1.19	1.23	1.27	1.24	1.27	1.31	1.36	1.31	1.34	1.39	1.44	1.37	1.40	1.45	1.50	1.42	1.45	1.50	1.56	
675	Amps	4.4	4.5	4.6	4.8	4.7	4.8	5.0	5.2	5.1	5.3	5.4	5.6	5.5	5.6	5.8	6.0	5.8	6.0	6.2	6.4	6.2	6.3	6.5	6.8	
	HI PR	223	240	244	249	252	271	275	281	287	309	313	320	327	352	357	364	368	396	401	410	412	443	449	459	
600	Lo PR	119	123	134	143	123	127	138	147	127	131	143	152	130	134	147	156	133	137	150	159	136	140	153	163	

IDB = Entering Indoor Dry Bulb Temperature
 High and low pressures are measured at the liquid and suction service valves.
 Shaded area reflects ACCA (TVA) conditions
 Amps = outdoor unit amps (comp.-fan)
 kW = Total system power

EXPANDED COOLING DATA — ASXC160241**/CA*F3636C6C*+TXV/MBVC1200** Low Stage (CONT.)

IDB	AIRFLOW	OUTDOOR AMBIENT TEMPERATURE												ENTERING INDOOR WET BULB TEMPERATURE											
		65°F				75°F				85°F				95°F				105°F				115°F			
		59	63	67	71	59	63	67	71	59	63	67	71	59	63	67	71	59	63	67	71	59	63	67	71
80	MBh	18.6	19.0	20.3	21.7	18.2	18.6	19.9	21.2	17.8	18.1	19.4	20.7	17.3	17.7	18.9	20.2	16.5	16.8	18.0	19.2	15.2	15.6	16.6	17.8
	S/T	0.93	0.88	0.71	0.53	0.97	0.91	0.74	0.55	1.00	0.93	0.76	0.57	1.00	0.96	0.78	0.58	1.00	1.00	0.81	0.61	1.00	1.00	0.82	0.61
	ΔT	24	23	20	16	24	23	20	16	24	23	20	16	24	23	20	16	22	23	20	16	21	21	19	15
	kW	1.10	1.12	1.16	1.20	1.19	1.21	1.25	1.30	1.26	1.29	1.34	1.38	1.33	1.37	1.41	1.46	1.39	1.43	1.48	1.53	1.44	1.48	1.53	1.58
	Amps	4.5	4.6	4.7	4.9	4.8	4.9	5.1	5.3	5.2	5.3	5.5	5.7	5.6	5.7	5.9	6.1	5.9	6.1	6.3	6.5	6.3	6.4	6.6	6.9
	HI PR	228	245	248	254	258	277	281	287	293	315	319	326	334	359	364	372	375	404	409	418	420	452	458	468
	Lo PR	122	125	137	146	125	129	141	150	129	133	146	155	133	137	150	159	135	140	153	162	139	143	156	166
	MBh	18.1	18.5	19.7	21.1	17.7	18.1	19.3	20.6	17.2	17.6	18.8	20.1	16.8	17.2	18.4	19.6	16.0	16.3	17.4	18.7	14.8	15.1	16.2	17.3
	S/T	0.89	0.84	0.68	0.51	0.92	0.87	0.70	0.53	0.95	0.89	0.72	0.54	0.98	0.92	0.75	0.56	1.00	0.95	0.77	0.58	1.00	0.96	0.78	0.58
	ΔT	25	24	21	16	25	24	21	17	25	24	21	17	25	24	21	17	24	24	21	17	23	22	19	15
kW	1.09	1.11	1.15	1.19	1.18	1.20	1.24	1.29	1.25	1.28	1.33	1.37	1.32	1.35	1.40	1.45	1.38	1.41	1.46	1.51	1.43	1.47	1.52	1.57	
Amps	4.4	4.5	4.7	4.8	4.8	4.9	5.0	5.2	5.2	5.3	5.5	5.7	5.5	5.7	5.8	6.1	5.9	6.0	6.2	6.4	6.2	6.4	6.6	6.8	
HI PR	226	243	246	251	255	274	278	284	290	312	316	323	330	355	360	368	372	400	405	414	416	447	454	464	
Lo PR	120	124	136	144	124	128	140	149	128	132	144	154	132	136	148	158	134	138	151	161	137	142	155	165	
MBh	16.7	17.1	18.2	19.5	16.3	16.7	17.8	19.0	15.9	16.3	17.4	18.6	15.5	15.9	17.0	18.1	14.8	15.1	16.1	17.2	13.7	14.0	14.9	15.9	
S/T	0.86	0.81	0.66	0.49	0.89	0.83	0.68	0.51	0.91	0.86	0.70	0.52	0.94	0.88	0.72	0.54	0.98	0.92	0.75	0.56	0.99	0.92	0.75	0.56	
ΔT	25	24	21	17	25	24	21	17	25	24	21	17	26	25	21	17	25	24	21	17	24	23	20	16	
kW	1.08	1.10	1.14	1.18	1.17	1.19	1.23	1.27	1.24	1.27	1.31	1.36	1.31	1.34	1.39	1.44	1.37	1.40	1.45	1.50	1.42	1.45	1.50	1.56	
Amps	4.4	4.5	4.6	4.8	4.7	4.8	5.0	5.2	5.1	5.3	5.4	5.6	5.5	5.6	5.8	6.0	5.8	6.0	6.2	6.4	6.2	6.3	6.5	6.8	
HI PR	223	240	244	249	252	271	275	281	287	309	313	320	327	352	357	364	368	396	401	410	412	443	449	459	
Lo PR	119	123	134	143	123	127	138	147	127	131	143	152	130	134	147	156	133	137	150	159	136	140	153	163	

85	MBh	19.0	19.3	20.2	21.6	18.5	18.9	19.8	21.1	18.1	18.4	19.3	20.6	17.6	18.0	18.8	20.1	16.8	17.1	17.9	19.1	15.5	15.8	16.6	17.7
	S/T	0.98	0.94	0.85	0.69	1.00	0.98	0.88	0.72	1.00	1.00	0.91	0.73	1.00	1.00	0.93	0.76	1.00	1.00	0.97	0.79	1.00	1.00	0.98	0.79
	ΔT	25	25	23	20	25	25	24	21	25	25	24	21	24	24	24	21	23	23	24	20	21	22	22	19
	kW	1.10	1.12	1.16	1.20	1.19	1.21	1.25	1.30	1.26	1.29	1.34	1.38	1.33	1.37	1.41	1.46	1.39	1.43	1.48	1.53	1.44	1.48	1.53	1.58
	Amps	4.5	4.6	4.7	4.9	4.8	4.9	5.1	5.3	5.2	5.3	5.5	5.7	5.6	5.7	5.9	6.1	5.9	6.1	6.3	6.5	6.3	6.4	6.6	6.9
	HI PR	228	245	248	254	258	277	281	287	293	315	319	326	334	359	364	372	375	404	409	418	420	452	458	468
	Lo PR	122	125	137	146	125	129	141	150	129	133	146	155	133	137	150	159	135	140	153	162	139	143	156	166
	MBh	18.4	18.8	19.6	21.0	18.0	18.3	19.2	20.5	17.5	17.9	18.7	20.0	17.1	17.4	18.3	19.5	16.3	16.6	17.4	18.5	15.1	15.4	16.1	17.2
	S/T	0.93	0.90	0.81	0.66	0.97	0.93	0.84	0.68	0.99	0.96	0.86	0.70	1.00	0.99	0.89	0.72	1.00	1.00	0.93	0.75	1.00	1.00	0.93	0.76
	ΔT	26	26	24	21	27	26	25	21	27	26	25	21	26	26	25	22	25	25	25	21	23	24	23	20
kW	1.09	1.11	1.15	1.19	1.18	1.20	1.24	1.29	1.25	1.28	1.33	1.37	1.32	1.35	1.40	1.45	1.38	1.41	1.46	1.51	1.43	1.47	1.52	1.57	
Amps	4.4	4.5	4.7	4.8	4.8	4.9	5.0	5.2	5.2	5.3	5.5	5.7	5.5	5.7	5.8	6.1	5.9	6.0	6.2	6.4	6.2	6.4	6.6	6.8	
HI PR	226	243	246	251	255	274	278	284	290	312	316	323	330	355	360	368	372	400	405	414	416	447	454	464	
Lo PR	120	124	136	144	124	128	140	149	128	132	144	154	132	136	148	158	134	138	151	161	137	142	155	165	
MBh	17.0	17.3	18.1	19.3	16.6	16.9	17.7	18.9	16.2	16.5	17.3	18.4	15.8	16.1	16.9	18.0	15.0	15.3	16.0	17.1	13.9	14.2	14.8	15.8	
S/T	0.90	0.87	0.78	0.64	0.93	0.90	0.81	0.66	0.96	0.92	0.83	0.68	0.99	0.95	0.86	0.70	1.00	0.99	0.89	0.72	1.00	1.00	0.90	0.73	
ΔT	26.8	26	25	22	27	27	25	22	27	27	25	22	27	27	25	22	26	26	25	22	24	25	23	20	
kW	1.08	1.10	1.14	1.18	1.17	1.19	1.23	1.27	1.24	1.27	1.31	1.36	1.31	1.34	1.39	1.44	1.37	1.40	1.45	1.50	1.42	1.45	1.50	1.56	
Amps	4.4	4.5	4.6	4.8	4.7	4.8	5.0	5.2	5.1	5.3	5.4	5.6	5.5	5.6	5.8	6.0	5.8	6.0	6.2	6.4	6.2	6.3	6.5	6.8	
HI PR	223	240	244	249	252	271	275	281	287	309	313	320	327	352	357	364	368	396	401	410	412	443	449	459	
Lo PR	119	123	134	143	123	127	138	147	127	131	143	152	130	134	147	156	133	137	150	159	136	140	153	163	

IDB = Entering Indoor Dry Bulb Temperature
 High and low pressures are measured at the liquid and suction service valves.
 Shaded area reflects AHRI (TVA) conditions
 Amps = outdoor unit amps (comp.-fan)
 kW = Total system power

EXPANDED COOLING DATA — ASXC160241**/CA*F3636C6C*+TXV/MBVC1200** HIGH STAGE

IDB	AIRFLOW	OUTDOOR AMBIENT TEMPERATURE																							
		65°F				75°F				85°F				95°F				105°F				115°F			
		59	63	67	71	59	63	67	71	59	63	67	71	59	63	67	71	59	63	67	71	59	63	67	71
70	MBh	23.5	24.4	26.7	-	23.0	23.8	26.1	-	22.4	23.2	25.5	-	21.9	22.7	24.8	-	20.8	21.5	23.6	-	19.3	20.0	21.9	-
	S/T	0.76	0.63	0.44	-	0.78	0.66	0.45	-	0.80	0.67	0.47	-	0.83	0.69	0.48	-	0.86	0.72	0.50	-	0.87	0.73	0.50	-
	ΔT	18	16	12	-	18	16	12	-	19	16	12	-	19	16	12	-	18	16	12	-	17	15	11	-
	kW	1.50	1.53	1.58	-	1.62	1.65	1.71	-	1.72	1.76	1.82	-	1.81	1.86	1.92	-	1.89	1.94	2.00	-	1.96	2.01	2.07	-
	Amps	5.9	6.0	6.2	-	6.4	6.5	6.7	-	6.9	7.1	7.3	-	7.4	7.5	7.8	-	7.8	8.0	8.3	-	8.3	8.5	8.7	-
	HI PR	237	255	258	-	268	288	292	-	304	327	332	-	347	373	378	-	390	419	425	-	437	470	476	-
	Lo PR	122	125	137	-	125	129	141	-	129	134	146	-	133	137	150	-	136	140	153	-	139	143	156	-
	MBh	22.8	23.7	25.9	-	22.3	23.1	25.3	-	21.8	22.6	24.7	-	21.2	22.0	24.1	-	20.2	20.9	22.9	-	18.7	19.4	21.2	-
	S/T	0.72	0.60	0.42	-	0.75	0.63	0.43	-	0.77	0.64	0.44	-	0.79	0.66	0.46	-	0.82	0.69	0.48	-	0.83	0.69	0.48	-
	ΔT	19	16	12	-	19	17	13	-	19	17	13	-	19	17	13	-	19	17	13	-	18	15	12	-
	kW	1.49	1.52	1.57	-	1.61	1.64	1.69	-	1.71	1.75	1.80	-	1.80	1.84	1.90	-	1.88	1.92	1.98	-	1.94	1.99	2.06	-
	Amps	5.9	6.0	6.2	-	6.3	6.5	6.7	-	6.8	7.0	7.2	-	7.3	7.5	7.7	-	7.8	7.9	8.2	-	8.2	8.4	8.7	-
HI PR	234	252	256	-	265	285	289	-	301	324	329	-	343	369	374	-	386	415	421	-	432	465	471	-	
Lo PR	120	124	136	-	124	128	140	-	128	132	144	-	132	136	148	-	134	138	151	-	138	142	155	-	
MBh	21.1	21.8	23.9	-	20.6	21.3	23.4	-	20.1	20.8	22.8	-	19.6	20.3	22.3	-	18.6	19.3	21.1	-	17.3	17.9	19.6	-	
S/T	0.70	0.58	0.40	-	0.72	0.60	0.42	-	0.74	0.62	0.43	-	0.76	0.64	0.44	-	0.79	0.66	0.46	-	0.80	0.67	0.46	-	
ΔT	19	17	13	-	20	17	13	-	20	17	13	-	20	17	13	-	19	17	13	-	18	16	12	-	
kW	1.48	1.51	1.56	-	1.59	1.63	1.68	-	1.69	1.73	1.79	-	1.78	1.82	1.89	-	1.86	1.90	1.97	-	1.93	1.97	2.04	-	
Amps	5.8	5.9	6.1	-	6.3	6.4	6.6	-	6.8	6.9	7.2	-	7.2	7.4	7.6	-	7.7	7.9	8.1	-	8.1	8.3	8.6	-	
HI PR	232	249	253	-	262	282	286	-	298	321	325	-	340	365	370	-	382	411	417	-	428	460	467	-	
Lo PR	119	123	134	-	123	127	138	-	127	131	143	-	130	134	147	-	133	137	150	-	136	140	153	-	

900	MBh	23.9	24.6	26.7	28.6	23.4	24.1	26.0	27.9	22.8	23.5	25.4	27.3	22.2	22.9	24.8	26.6	21.1	21.8	23.6	25.3	19.6	20.2	21.8	23.4
	S/T	0.86	0.77	0.58	0.37	0.89	0.80	0.60	0.39	0.91	0.82	0.62	0.40	0.94	0.84	0.64	0.41	0.98	0.88	0.66	0.43	0.99	0.88	0.67	0.43
	ΔT	21	19	16	11	21	20	16	11	21	20	16	11	21	20	16	11	21	19	16	11	20	18	15	10
	kW	1.50	1.53	1.58	1.63	1.62	1.65	1.71	1.77	1.72	1.76	1.82	1.88	1.81	1.86	1.92	1.98	1.89	1.94	2.00	2.07	1.96	2.01	2.07	2.15
	Amps	5.9	6.0	6.2	6.5	6.4	6.5	6.7	7.0	6.9	7.1	7.3	7.6	7.4	7.5	7.8	8.1	7.8	8.0	8.3	8.6	8.3	8.5	8.7	9.1
	HI PR	237	255	258	264	268	288	292	298	304	327	332	339	347	373	378	386	390	419	425	435	437	470	476	487
	Lo PR	122	125	137	146	125	129	141	150	129	134	146	155	133	137	150	159	136	140	153	163	139	143	156	167
	MBh	23.2	23.9	25.9	27.8	22.7	23.4	25.3	27.1	22.1	22.8	24.7	26.5	21.6	22.2	24.1	25.8	20.5	21.1	22.9	24.5	19.0	19.6	21.2	22.7
	S/T	0.82	0.73	0.56	0.36	0.85	0.76	0.58	0.37	0.87	0.78	0.59	0.38	0.90	0.81	0.61	0.39	0.93	0.84	0.63	0.41	0.94	0.84	0.64	0.41
	ΔT	22	20	17	11	22	20	17	12	22	20	17	12	22	21	17	12	22	20	17	11	21	19	16	11
	kW	1.49	1.52	1.57	1.62	1.61	1.64	1.69	1.75	1.71	1.75	1.80	1.87	1.80	1.84	1.90	1.97	1.88	1.92	1.98	2.05	1.94	1.99	2.06	2.13
	Amps	5.9	6.0	6.2	6.4	6.3	6.5	6.7	6.9	6.8	7.0	7.2	7.5	7.3	7.5	7.7	8.0	7.8	7.9	8.2	8.5	8.2	8.4	8.7	9.0
HI PR	234	252	256	261	265	285	289	295	301	324	329	336	343	369	374	382	386	415	421	430	432	465	471	482	
Lo PR	120	124	136	144	124	128	140	149	128	132	144	154	132	136	148	158	134	138	151	161	138	142	155	165	
MBh	21.4	22.1	23.9	25.6	20.9	21.6	23.3	25.0	20.4	21.0	22.8	24.4	19.9	20.5	22.2	23.8	18.9	19.5	21.1	22.7	17.5	18.1	19.6	21.0	
S/T	0.79	0.71	0.54	0.34	0.82	0.73	0.56	0.36	0.84	0.75	0.57	0.37	0.87	0.78	0.59	0.38	0.90	0.81	0.61	0.39	0.91	0.81	0.62	0.40	
ΔT	22	21	17	12	23	21	17	12	23	21	17	12	23	21	17	12	23	21	17	12	21	19	16	11	
kW	1.48	1.51	1.56	1.61	1.59	1.63	1.68	1.74	1.69	1.73	1.79	1.85	1.78	1.82	1.89	1.95	1.86	1.90	1.97	2.04	1.93	1.97	2.04	2.11	
Amps	5.8	5.9	6.1	6.3	6.3	6.4	6.6	6.8	6.8	6.9	7.2	7.4	7.2	7.4	7.6	7.9	7.7	7.9	8.1	8.4	8.1	8.3	8.6	8.9	
HI PR	232	249	253	259	262	282	286	292	298	321	325	332	340	365	370	379	382	411	417	426	428	460	467	477	
Lo PR	119	123	134	143	123	127	138	147	127	131	143	152	130	134	147	156	133	137	150	159	136	140	153	163	

IDB = Entering Indoor Dry Bulb Temperature
 High and low pressures are measured at the liquid and suction service valves.
 Shaded area reflects ACCA (TVA) conditions
 Amps = outdoor unit amps (comp.+fan)
 kW = Total system power

EXPANDED COOLING DATA — ASXC160241**/CA*F3636C6C*+TXV/MBVC1200** HIGH STAGE (CONT.)

IDB	AIRFLOW	OUTDOOR AMBIENT TEMPERATURE												ENTERING INDOOR WET BULB TEMPERATURE												
		65°F				75°F				85°F				95°F				105°F				115°F				
		59	63	67	71	59	63	67	71	59	63	67	71	59	63	67	71	59	63	67	71	59	63	67	71	
80	900	MBh	24.3	24.9	26.6	28.4	23.8	24.3	26.0	27.7	23.2	23.7	25.3	27.1	22.6	23.1	24.7	26.4	21.5	22.0	23.5	25.1	19.9	20.4	21.8	23.3
		S/T	0.94	0.89	0.72	0.54	1.00	0.92	0.75	0.56	1.00	0.94	0.77	0.57	1.00	1.00	0.79	0.59	1.00	1.00	0.82	0.61	1.00	1.00	0.83	0.62
	ΔT	23	22	20	16	24	23	20	16	23	24	20	16	23	24	20	16	22	22	20	16	20	21	18	15	
	kW	1.50	1.53	1.58	1.63	1.62	1.65	1.71	1.77	1.72	1.76	1.82	1.88	1.81	1.86	1.92	1.98	1.89	1.94	2.00	2.07	1.96	2.01	2.07	2.15	
	Amps	5.9	6.0	6.2	6.5	6.4	6.5	6.7	7.0	6.9	7.1	7.3	7.6	7.4	7.5	7.8	8.1	7.8	8.0	8.3	8.6	8.3	8.5	8.7	9.1	
	H1 PR	237	255	258	264	268	288	292	298	304	327	332	339	347	373	378	386	390	419	425	435	437	470	476	487	
	Lo PR	122	125	137	146	125	129	141	150	129	134	146	155	133	137	150	159	136	140	153	163	139	143	156	167	
	MBh	23.6	24.1	25.8	27.6	23.1	23.6	25.2	26.9	22.5	23.0	24.6	26.3	22.0	22.5	24.0	25.7	20.9	21.3	22.8	24.4	19.3	19.8	21.1	22.6	
	S/T	0.90	0.84	0.69	0.51	0.93	0.88	0.71	0.53	0.96	0.90	0.73	0.55	0.99	0.93	0.75	0.56	1.00	0.96	0.78	0.58	1.00	0.97	0.79	0.59	
	ΔT	24	23	20	16	25	24	21	16	25	24	21	16	25	24	21	17	24	24	21	16	22	22	19	15	
kW	1.49	1.52	1.57	1.62	1.61	1.64	1.69	1.75	1.71	1.75	1.80	1.87	1.80	1.84	1.90	1.97	1.88	1.92	1.98	2.05	1.94	1.99	2.06	2.13		
Amps	5.9	6.0	6.2	6.4	6.3	6.5	6.7	6.9	6.8	7.0	7.2	7.5	7.3	7.5	7.7	8.0	7.8	7.9	8.2	8.5	8.2	8.4	8.7	9.0		
H1 PR	234	252	256	261	265	285	289	295	301	324	329	336	343	369	374	382	386	415	421	430	432	465	471	482		
Lo PR	120	124	136	144	124	128	140	149	128	132	144	154	132	136	148	158	134	138	151	161	138	142	155	165		
MBh	21.8	22.3	23.8	25.5	21.3	21.8	23.3	24.9	20.8	21.3	22.7	24.3	20.3	20.7	22.2	23.7	19.3	19.7	21.0	22.5	17.9	18.2	19.5	20.8		
S/T	0.87	0.81	0.66	0.50	0.90	0.84	0.69	0.51	0.92	0.87	0.70	0.53	0.95	0.89	0.73	0.54	0.99	0.93	0.75	0.56	1.00	0.93	0.76	0.57		
ΔT	25	24	21	17	25	24	21	17	25	24	21	17	25	24	21	17	25	24	21	17	23	22	19	16		
kW	1.48	1.51	1.56	1.61	1.59	1.63	1.68	1.74	1.69	1.73	1.79	1.85	1.78	1.82	1.89	1.95	1.86	1.90	1.97	2.04	1.93	1.97	2.04	2.11		
Amps	5.8	5.9	6.1	6.3	6.3	6.4	6.6	6.8	6.8	6.9	7.2	7.4	7.2	7.4	7.6	7.9	7.7	7.9	8.1	8.4	8.1	8.3	8.6	8.9		
H1 PR	232	249	253	259	262	282	286	292	298	321	325	332	340	365	370	379	382	411	417	426	428	460	467	477		
Lo PR	119	123	134	143	123	127	138	147	127	131	143	152	130	134	147	156	133	137	150	159	136	140	153	163		

85	900	MBh	24.8	25.2	26.4	28.2	24.2	24.7	25.8	27.6	23.6	24.1	25.2	26.9	23.0	23.5	24.6	26.2	21.9	22.3	23.4	24.9	20.3	20.7	21.6	23.1
		S/T	0.99	0.96	0.86	0.70	1.00	0.99	0.89	0.72	1.00	1.00	0.92	0.74	1.00	1.00	0.95	0.77	1.00	1.00	0.98	0.80	1.00	1.00	0.99	0.80
	ΔT	25	25	23	20	25	25	24	20	24	25	24	20	24	24	24	21	22	23	23	20	21	21	22	19	
	kW	1.50	1.53	1.58	1.63	1.62	1.65	1.71	1.77	1.72	1.76	1.82	1.88	1.81	1.86	1.92	1.98	1.89	1.94	2.00	2.07	1.96	2.01	2.07	2.15	
	Amps	5.9	6.0	6.2	6.5	6.4	6.5	6.7	7.0	6.9	7.1	7.3	7.6	7.4	7.5	7.8	8.1	7.8	8.0	8.3	8.6	8.3	8.5	8.7	9.1	
	H1 PR	237	255	258	264	268	288	292	298	304	327	332	339	347	373	378	386	390	419	425	435	437	470	476	487	
	Lo PR	122	125	137	146	125	129	141	150	129	134	146	155	133	137	150	159	136	140	153	163	139	143	156	167	
	MBh	24.0	24.5	25.7	27.4	23.5	23.9	25.1	26.8	22.9	23.4	24.5	26.1	22.4	22.8	23.9	25.5	21.2	21.7	22.7	24.2	19.7	20.1	21.0	22.4	
	S/T	0.94	0.91	0.82	0.67	0.98	0.94	0.85	0.69	1.00	0.97	0.87	0.71	1.00	1.00	0.90	0.73	1.00	1.00	0.94	0.76	1.00	1.00	0.94	0.77	
	ΔT	26	26	24	21	26	26	25	21	26	26	25	21	26	26	25	21	24	25	24	21	23	23	23	20	
kW	1.49	1.52	1.57	1.62	1.61	1.64	1.69	1.75	1.71	1.75	1.80	1.87	1.80	1.84	1.90	1.97	1.88	1.92	1.98	2.05	1.94	1.99	2.06	2.13		
Amps	5.9	6.0	6.2	6.4	6.3	6.5	6.7	6.9	6.8	7.0	7.2	7.5	7.3	7.5	7.7	8.0	7.8	7.9	8.2	8.5	8.2	8.4	8.7	9.0		
H1 PR	234	252	256	261	265	285	289	295	301	324	329	336	343	369	374	382	386	415	421	430	432	465	471	482		
Lo PR	120	124	136	144	124	128	140	149	128	132	144	154	132	136	148	158	134	138	151	161	138	142	155	165		
MBh	22.2	22.6	23.7	25.3	21.7	22.1	23.1	24.7	21.2	21.6	22.6	24.1	20.6	21.0	22.0	23.5	19.6	20.0	20.9	22.3	18.2	18.5	19.4	20.7		
S/T	0.91	0.88	0.79	0.64	0.94	0.91	0.82	0.67	0.97	0.93	0.84	0.68	1.00	0.96	0.87	0.71	1.00	1.00	0.90	0.73	1.00	1.00	0.91	0.74		
ΔT	26.5	26	25	21	27	26	25	22	27	26	25	22	27	27	25	22	26	26	25	21	24	24	23	20		
kW	1.48	1.51	1.56	1.61	1.59	1.63	1.68	1.74	1.69	1.73	1.79	1.85	1.78	1.82	1.89	1.95	1.86	1.90	1.97	2.04	1.93	1.97	2.04	2.11		
Amps	5.8	5.9	6.1	6.3	6.3	6.4	6.6	6.8	6.8	6.9	7.2	7.4	7.2	7.4	7.6	7.9	7.7	7.9	8.1	8.4	8.1	8.3	8.6	8.9		
H1 PR	232	249	253	259	262	282	286	292	298	321	325	332	340	365	370	379	382	411	417	426	428	460	467	477		
Lo PR	119	123	134	143	123	127	138	147	127	131	143	152	130	134	147	156	133	137	150	159	136	140	153	163		

IDB = Entering Indoor Dry Bulb Temperature
 High and low pressures are measured at the liquid and suction service valves.
 Shaded area reflects AHRH (TVA) conditions
 Amps = outdoor unit amps (comp.+fan)
 kW = Total system power

EXPANDED COOLING DATA — ASXC160361** / CA*F3743*6A* +TXV / MBVC1600** Low Stage

IDB	AIRFLOW	OUTDOOR AMBIENT TEMPERATURE												ENTERING INDOOR WET BULB TEMPERATURE													
		65°F				75°F				85°F				95°F				105°F				115°F					
		59	63	67	71	59	63	67	71	59	63	67	71	59	63	67	71	59	63	67	71	59	63	67	71		
70	904	MBh	24.9	25.8	28.3	-	24.3	25.2	27.6	-	23.8	24.6	27.0	-	23.2	24.0	26.3	-	22.0	22.8	25.0	-	20.4	21.1	23.2	-	
		S/T	0.72	0.60	0.41	-	0.74	0.62	0.43	-	0.76	0.64	0.44	-	0.79	0.66	0.45	-	0.82	0.68	0.47	-	0.82	0.69	0.48	-	
		ΔT	18	16	12	-	18	16	12	-	18	16	12	-	19	16	12	-	18	16	12	-	17	15	11	-	
	800	KW	1.50	1.53	1.58	-	1.61	1.65	1.70	-	1.72	1.75	1.81	-	1.81	1.85	1.91	-	1.88	1.93	1.99	-	1.95	2.00	2.06	-	
		Amps	5.8	6.0	6.2	-	6.3	6.4	6.6	-	6.8	7.0	7.2	-	7.3	7.4	7.7	-	7.7	7.9	8.1	-	8.2	8.3	8.6	-	
		HI PR	220	237	240	-	249	268	271	-	283	304	309	-	322	347	352	-	348	374	380	-	413	444	450	-	
	696	Lo PR	119	123	134	-	123	127	138	-	127	131	143	-	130	135	147	-	133	137	150	-	136	141	153	-	
		MBh	24.2	25.1	27.5	-	23.6	24.5	26.8	-	23.1	23.9	26.2	-	22.5	23.3	25.5	-	21.4	22.2	24.3	-	19.8	20.5	22.5	-	
		S/T	0.68	0.57	0.40	-	0.71	0.59	0.41	-	0.73	0.61	0.42	-	0.75	0.63	0.43	-	0.78	0.65	0.45	-	0.78	0.65	0.45	-	
	75	904	ΔT	19	16	12	-	19	17	13	-	19	17	13	-	19	17	13	-	19	17	13	-	18	15	12	-
			KW	1.49	1.52	1.57	-	1.60	1.64	1.69	-	1.70	1.74	1.80	-	1.79	1.83	1.89	-	1.87	1.91	1.97	-	1.93	1.98	2.04	-
			Amps	5.8	5.9	6.1	-	6.2	6.4	6.6	-	6.7	6.9	7.1	-	7.2	7.4	7.6	-	7.6	7.8	8.1	-	8.1	8.3	8.5	-
800		HI PR	218	234	238	-	246	265	269	-	280	301	306	-	319	343	348	-	345	371	376	-	409	439	446	-	
		Lo PR	118	122	133	-	122	125	137	-	126	130	142	-	129	133	145	-	132	136	148	-	135	139	152	-	
		MBh	22.3	23.1	25.3	-	21.8	22.6	24.8	-	21.3	22.1	24.2	-	20.8	21.5	23.6	-	19.7	20.4	22.4	-	18.3	18.9	20.8	-	
696		S/T	0.66	0.55	0.38	-	0.68	0.57	0.39	-	0.70	0.58	0.40	-	0.72	0.60	0.42	-	0.75	0.63	0.43	-	0.76	0.63	0.44	-	
		ΔT	19	17	13	-	20	17	13	-	20	17	13	-	20	17	13	-	20	17	13	-	18	16	12	-	
		KW	1.47	1.51	1.55	-	1.59	1.62	1.67	-	1.69	1.73	1.78	-	1.78	1.82	1.88	-	1.85	1.89	1.96	-	1.92	1.96	2.03	-	
75		904	Amps	5.7	5.9	6.0	-	6.2	6.3	6.5	-	6.7	6.8	7.1	-	7.1	7.3	7.5	-	7.6	7.8	8.0	-	8.0	8.2	8.5	-
			HI PR	216	232	235	-	244	262	266	-	277	298	303	-	316	340	345	-	341	367	372	-	404	435	441	-
			Lo PR	117	121	132	-	120	124	136	-	125	128	140	-	128	132	144	-	130	134	147	-	134	138	150	-
	800	MBh	25.3	26.1	28.2	30.3	24.7	25.5	27.6	29.6	24.2	24.9	26.9	28.9	23.6	24.3	26.3	28.2	22.4	23.0	24.9	26.8	20.7	21.4	23.1	24.8	
		S/T	0.81	0.73	0.55	0.35	0.84	0.75	0.57	0.37	0.87	0.77	0.59	0.38	0.89	0.80	0.60	0.39	0.93	0.83	0.63	0.40	0.93	0.84	0.63	0.41	
		ΔT	21	19	16	11	21	20	16	11	21	20	16	11	21	20	16	11	21	19	16	11	20	18	15	10	
	696	kW	1.50	1.53	1.58	1.63	1.61	1.65	1.70	1.76	1.72	1.75	1.81	1.87	1.81	1.85	1.91	1.97	1.88	1.93	1.99	2.06	1.95	2.00	2.06	2.13	
		Amps	5.8	6.0	6.2	6.4	6.3	6.4	6.6	6.9	6.8	7.0	7.2	7.4	7.3	7.4	7.7	7.9	7.7	7.9	8.1	8.4	8.2	8.3	8.6	8.9	
		HI PR	220	237	240	245	249	268	271	277	283	304	309	315	322	347	352	359	348	374	380	388	413	444	450	460	
	75	904	Lo PR	119	123	134	143	123	127	138	147	127	131	143	152	130	135	147	156	133	137	150	160	136	141	153	163
			MBh	24.6	25.3	27.4	29.4	24.0	24.7	26.8	28.7	23.5	24.1	26.1	28.0	22.9	23.6	25.5	27.4	21.7	22.4	24.2	26.0	20.1	20.7	22.4	24.1
			S/T	0.78	0.69	0.53	0.34	0.80	0.72	0.54	0.35	0.83	0.74	0.56	0.36	0.85	0.76	0.58	0.37	0.88	0.79	0.60	0.38	0.89	0.80	0.60	0.39
800		ΔT	22	20	17	11	22	20	17	12	22	20	17	12	22	21	17	12	22	20	17	12	21	19	16	11	
		kW	1.49	1.52	1.57	1.62	1.60	1.64	1.69	1.74	1.70	1.74	1.80	1.86	1.79	1.83	1.89	1.96	1.87	1.91	1.97	2.04	1.93	1.98	2.04	2.11	
		Amps	5.8	5.9	6.1	6.3	6.2	6.4	6.6	6.8	6.7	6.9	7.1	7.4	7.2	7.4	7.6	7.9	7.6	7.8	8.1	8.4	8.1	8.3	8.5	8.9	
696		HI PR	218	234	238	243	246	265	269	275	280	301	306	312	319	343	348	356	345	371	376	384	409	439	446	455	
		Lo PR	118	122	133	142	122	125	137	146	126	130	142	151	129	133	145	155	132	136	148	158	135	139	152	162	
		MBh	22.7	23.4	25.3	27.2	22.2	22.8	24.7	26.5	21.6	22.3	24.1	25.9	21.1	21.7	23.5	25.3	20.1	20.7	22.4	24.0	18.6	19.1	20.7	22.2	
75		904	S/T	0.75	0.67	0.51	0.33	0.78	0.69	0.53	0.34	0.80	0.71	0.54	0.35	0.82	0.73	0.56	0.36	0.85	0.76	0.58	0.37	0.86	0.77	0.58	0.37
			ΔT	22	21	17	12	23	21	17	12	23	21	17	12	23	21	17	12	23	21	17	12	21	19	16	11
			kW	1.47	1.51	1.55	1.60	1.59	1.62	1.67	1.73	1.69	1.73	1.78	1.84	1.78	1.82	1.88	1.94	1.85	1.89	1.96	2.02	1.92	1.96	2.03	2.10
	696	Amps	5.7	5.9	6.0	6.3	6.2	6.3	6.5	6.8	6.7	6.8	7.1	7.3	7.1	7.3	7.5	7.8	7.6	7.8	8.0	8.3	8.0	8.2	8.5	8.8	
		HI PR	216	232	235	241	244	262	266	272	277	298	303	309	316	340	345	352	341	367	372	380	404	435	441	451	
		Lo PR	117	121	132	140	120	124	136	144	125	128	140	149	128	132	144	153	130	134	147	156	134	138	150	160	

IDB = Entering Indoor Dry Bulb Temperature
 High and low pressures are measured at the liquid and suction service valves.
 Shaded area reflects ACCA (TVA) conditions
 Amps = outdoor unit amps (comp. +fan)
 kW = Total system power

EXPANDED COOLING DATA — ASXC160361** / CA*F3743*6A* +TXV / MBVC1600** LOW STAGE (CONT.)

IDB	AIRFLOW	OUTDOOR AMBIENT TEMPERATURE												ENTERING INDOOR WET BULB TEMPERATURE											
		65°F				75°F				85°F				95°F				105°F				115°F			
		59	63	67	71	59	63	67	71	59	63	67	71	59	63	67	71	59	63	67	71	59	63	67	71
80	MBh	25.8	26.3	28.1	30.1	25.2	25.7	27.5	29.4	24.6	25.1	26.8	28.7	24.0	24.5	26.2	28.0	22.8	23.3	24.9	26.6	21.1	21.6	23.0	24.6
	S/T	0.89	0.84	0.68	0.51	0.93	0.87	0.71	0.53	0.95	0.89	0.72	0.54	1.00	0.92	0.75	0.56	1.00	0.95	0.78	0.58	1.00	0.96	0.78	0.58
	ΔT	23	22	20	16	24	23	20	16	24	23	20	16	24	23	20	16	23	23	20	16	21	21	18	15
	kW	1.50	1.53	1.58	1.63	1.61	1.65	1.70	1.76	1.72	1.75	1.81	1.87	1.81	1.85	1.91	1.97	1.88	1.93	1.99	2.06	1.95	2.00	2.06	2.13
	Amps	5.8	6.0	6.2	6.4	6.3	6.4	6.6	6.9	6.8	7.0	7.2	7.4	7.3	7.4	7.7	7.9	7.7	7.9	8.1	8.4	8.2	8.3	8.6	8.9
	Hi PR	220	237	240	245	249	268	271	277	283	304	309	315	322	347	352	359	348	374	380	388	413	444	450	460
	Lo PR	119	123	134	143	123	127	138	147	127	131	143	152	130	135	147	156	133	137	150	160	136	141	153	163
	MBh	25.0	25.6	27.3	29.2	24.4	25.0	26.7	28.5	23.9	24.4	26.1	27.9	23.3	23.8	25.4	27.2	22.1	22.6	24.1	25.8	20.5	20.9	22.4	23.9
	S/T	0.85	0.80	0.65	0.49	0.88	0.83	0.67	0.50	0.90	0.85	0.69	0.52	0.93	0.88	0.71	0.53	0.97	0.91	0.74	0.55	0.98	0.92	0.75	0.56
	ΔT	24	23	20	16	25	24	21	17	25	24	21	17	25	24	21	17	25	24	21	16	23	22	19	15
kW	1.49	1.52	1.57	1.62	1.60	1.64	1.69	1.74	1.70	1.74	1.80	1.86	1.79	1.83	1.89	1.96	1.87	1.91	1.97	2.04	1.93	1.98	2.04	2.11	
Amps	5.8	5.9	6.1	6.3	6.2	6.4	6.6	6.8	6.7	6.9	7.1	7.4	7.2	7.4	7.6	7.9	7.6	7.8	8.1	8.4	8.1	8.3	8.5	8.9	
Hi PR	218	234	238	243	246	265	269	275	280	301	306	312	319	343	348	356	345	371	376	384	409	439	446	455	
Lo PR	118	122	133	142	122	125	137	146	126	130	142	151	129	133	145	155	132	136	148	158	135	139	152	162	
MBh	23.1	23.6	25.2	27.0	22.6	23.1	24.6	26.3	22.0	22.5	24.1	25.7	21.5	22.0	23.5	25.1	20.4	20.9	22.3	23.8	18.9	19.3	20.6	22.1	
S/T	0.82	0.77	0.63	0.47	0.85	0.80	0.65	0.49	0.87	0.82	0.67	0.50	0.90	0.84	0.69	0.51	0.93	0.88	0.71	0.53	0.94	0.88	0.72	0.54	
ΔT	25	24	21	17	25	24	21	17	25	24	21	17	26	25	21	17	25	24	21	17	24	23	20	16	
kW	1.47	1.51	1.55	1.60	1.59	1.62	1.67	1.73	1.69	1.73	1.78	1.84	1.78	1.82	1.88	1.94	1.85	1.89	1.96	2.02	1.92	1.96	2.03	2.10	
Amps	5.7	5.9	6.0	6.3	6.2	6.3	6.5	6.8	6.7	6.8	7.1	7.3	7.1	7.3	7.5	7.8	7.6	7.8	8.0	8.3	8.0	8.2	8.5	8.8	
Hi PR	216	232	235	241	244	262	266	272	277	298	303	309	316	340	345	352	341	367	372	380	404	435	441	451	
Lo PR	117	121	132	140	120	124	136	144	125	128	140	149	128	132	144	153	130	134	147	156	134	138	150	160	

MBh	26.2	26.7	28.0	29.9	25.6	26.1	27.4	29.2	25.0	25.5	26.7	28.5	24.4	24.9	26.1	27.8	23.2	23.6	24.8	26.4	21.5	21.9	22.9	24.5
S/T	0.94	0.90	0.82	0.66	0.97	0.94	0.84	0.69	0.99	0.96	0.87	0.70	1.00	0.99	0.89	0.73	1.00	1.00	0.93	0.75	1.00	1.00	0.94	0.76
ΔT	25	25	23	20	25	25	24	20	25	25	24	20	25	25	24	21	24	24	23	20	22	22	22	19
kW	1.50	1.53	1.58	1.63	1.61	1.65	1.70	1.76	1.72	1.75	1.81	1.87	1.81	1.85	1.91	1.97	1.88	1.93	1.99	2.06	1.95	2.00	2.06	2.13
Amps	5.8	6.0	6.2	6.4	6.3	6.4	6.6	6.9	6.8	6.8	7.0	7.4	7.3	7.4	7.7	7.9	7.7	7.9	8.1	8.4	8.2	8.3	8.6	8.9
Hi PR	220	237	240	245	249	268	271	277	283	304	309	315	322	347	352	359	348	374	380	388	413	444	450	460
Lo PR	119	123	134	143	123	127	138	147	127	131	143	152	130	135	147	156	133	137	150	160	136	141	153	163
MBh	25.5	26.0	27.2	29.0	24.9	25.4	26.6	28.3	24.3	24.8	25.9	27.7	23.7	24.2	25.3	27.0	22.5	22.9	24.0	25.6	20.8	21.3	22.3	23.7
S/T	0.89	0.86	0.78	0.63	0.93	0.89	0.81	0.65	0.95	0.92	0.83	0.67	0.98	0.94	0.85	0.69	1.00	0.98	0.89	0.72	1.00	0.99	0.89	0.72
ΔT	26	26	24	21	26	26	25	21	26	26	25	21	27	26	25	21	26	26	24	21	24	24	23	20
kW	1.49	1.52	1.57	1.62	1.60	1.64	1.69	1.74	1.70	1.74	1.80	1.86	1.79	1.83	1.89	1.96	1.87	1.91	1.97	2.04	1.93	1.98	2.04	2.11
Amps	5.8	5.9	6.1	6.3	6.2	6.4	6.6	6.8	6.7	6.9	7.1	7.4	7.2	7.4	7.6	7.9	7.6	7.8	8.1	8.4	8.1	8.3	8.5	8.9
Hi PR	218	234	238	243	246	265	269	275	280	301	306	312	319	343	348	356	345	371	376	384	409	439	446	455
Lo PR	118	122	133	142	122	125	137	146	126	130	142	151	129	133	145	155	132	136	148	158	135	139	152	162
MBh	23.5	24.0	25.1	26.8	23.0	23.4	24.5	26.2	22.4	22.8	23.9	25.5	21.9	22.3	23.3	24.9	20.8	21.2	22.2	23.7	19.2	19.6	20.5	21.9
S/T	0.86	0.83	0.75	0.61	0.89	0.86	0.78	0.63	0.91	0.88	0.80	0.65	0.94	0.91	0.82	0.67	0.98	0.95	0.85	0.69	0.99	0.95	0.86	0.70
ΔT	26.7	26	25	22	27	27	25	22	27	27	25	22	27	27	25	22	27	26	25	22	25	25	23	20
kW	1.47	1.51	1.55	1.60	1.59	1.62	1.67	1.73	1.69	1.73	1.78	1.84	1.78	1.82	1.88	1.94	1.85	1.89	1.96	2.02	1.92	1.96	2.03	2.10
Amps	5.7	5.9	6.0	6.3	6.2	6.3	6.5	6.8	6.7	6.8	7.1	7.3	7.1	7.3	7.5	7.8	7.6	7.8	8.0	8.3	8.0	8.2	8.5	8.8
Hi PR	216	232	235	241	244	262	266	272	277	298	303	309	316	340	345	352	341	367	372	380	404	435	441	451
Lo PR	117	121	132	140	120	124	136	144	125	128	140	149	128	132	144	153	130	134	147	156	134	138	150	160

IDB = Entering Indoor Dry Bulb Temperature
 High and low pressures are measured at the liquid and suction service valves.
 Shaded area reflects AHRI (TVA) conditions
 Amps = outdoor unit amps (comp.+fan)
 kW = Total system power

EXPANDED COOLING DATA — ASXC160361** / CA*F3743*6A* +TXV / MBVC1600** HIGH STAGE

IDB	AIRFLOW	OUTDOOR AMBIENT TEMPERATURE																									
		65°F				75°F				85°F				95°F				105°F				115°F					
		59	63	67	71	59	63	67	71	59	63	67	71	59	63	67	71	59	63	67	71	59	63	67	71		
70	1356	MBh	33.9	35.1	38.5	-	33.1	34.3	37.6	-	32.3	33.5	36.7	-	31.5	32.7	35.8	-	30.0	31.1	34.0	-	27.8	28.8	31.5	-	
		S/T	0.72	0.60	0.42	-	0.74	0.62	0.43	-	0.76	0.64	0.44	-	0.79	0.66	0.46	-	0.82	0.68	0.47	-	0.82	0.69	0.48	-	
	ΔT	17	14	11	-	17	14	11	-	17	14	11	-	17	15	11	-	17	14	11	-	16	13	10	-		
	1200	kW	2.14	2.18	2.25	-	2.31	2.36	2.43	-	2.45	2.51	2.59	-	2.58	2.64	2.73	-	2.69	2.76	2.85	-	2.79	2.85	2.95	-	
		Amps	8.1	8.3	8.6	-	8.8	9.0	9.3	-	9.5	9.7	10.0	-	10.1	10.4	10.7	-	10.8	11.1	11.4	-	11.4	11.7	12.1	-	
	1043	MBh	17	15	11	-	17	15	11	-	18	15	11	-	18	15	12	-	17	15	11	-	16	14	11	-	
		S/T	0.68	0.57	0.40	-	0.71	0.59	0.41	-	0.73	0.61	0.42	-	0.75	0.63	0.43	-	0.78	0.65	0.45	-	0.79	0.66	0.45	-	
	75	1356	MBh	34.5	35.5	38.4	41.2	33.7	34.7	37.5	40.3	32.9	33.8	36.6	39.3	32.1	33.0	35.7	38.4	30.5	31.4	34.0	36.4	28.2	29.1	31.5	33.8
			S/T	0.82	0.73	0.55	0.36	0.85	0.76	0.57	0.37	0.87	0.78	0.59	0.38	0.90	0.80	0.61	0.39	0.93	0.83	0.63	0.40	0.94	0.84	0.63	0.41
		ΔT	19	18	14	10	19	18	15	10	19	18	15	10	19	18	15	10	19	18	14	10	18	17	14	9	
		1200	kW	2.14	2.18	2.25	2.33	2.31	2.36	2.43	2.51	2.45	2.51	2.59	2.68	2.58	2.64	2.73	2.82	2.69	2.76	2.85	2.95	2.79	2.85	2.95	3.05
			Amps	8.1	8.3	8.6	8.9	8.8	9.0	9.3	9.6	9.5	9.7	10.0	10.4	10.1	10.4	10.7	11.1	10.8	11.1	11.4	11.9	11.4	11.7	12.1	12.6
1043		MBh	17	15	12	-	17	15	12	-	18	15	12	-	18	16	12	-	18	15	12	-	17	14	11	-	
		S/T	0.66	0.55	0.38	-	0.68	0.57	0.40	-	0.70	0.59	0.41	-	0.72	0.61	0.42	-	0.75	0.63	0.44	-	0.76	0.63	0.44	-	
70		1356	MBh	34.5	35.5	38.4	41.2	33.7	34.7	37.5	40.3	32.9	33.8	36.6	39.3	32.1	33.0	35.7	38.4	30.5	31.4	34.0	36.4	28.2	29.1	31.5	33.8
			S/T	0.82	0.73	0.55	0.36	0.85	0.76	0.57	0.37	0.87	0.78	0.59	0.38	0.90	0.80	0.61	0.39	0.93	0.83	0.63	0.40	0.94	0.84	0.63	0.41
		ΔT	19	18	14	10	19	18	15	10	19	18	15	10	19	18	15	10	19	18	14	10	18	17	14	9	
		1200	kW	2.14	2.18	2.25	2.33	2.31	2.36	2.43	2.51	2.45	2.51	2.59	2.68	2.58	2.64	2.73	2.82	2.69	2.76	2.85	2.95	2.79	2.85	2.95	3.03
			Amps	8.0	8.2	8.5	8.8	8.7	8.9	9.2	9.5	9.4	9.6	9.9	10.2	10.0	10.2	10.5	10.8	10.6	10.9	11.2	11.5	11.2	11.5	11.9	12.3
	1043	MBh	17	15	12	-	17	15	12	-	18	15	12	-	18	16	12	-	18	15	12	-	17	14	11	-	
		S/T	0.66	0.55	0.38	-	0.68	0.57	0.40	-	0.70	0.59	0.41	-	0.72	0.61	0.42	-	0.75	0.63	0.44	-	0.76	0.63	0.44	-	

IDB	AIRFLOW	OUTDOOR AMBIENT TEMPERATURE																									
		65°F				75°F				85°F				95°F				105°F				115°F					
		59	63	67	71	59	63	67	71	59	63	67	71	59	63	67	71	59	63	67	71	59	63	67	71		
75	1356	MBh	34.5	35.5	38.4	41.2	33.7	34.7	37.5	40.3	32.9	33.8	36.6	39.3	32.1	33.0	35.7	38.4	30.5	31.4	34.0	36.4	28.2	29.1	31.5	33.8	
		S/T	0.82	0.73	0.55	0.36	0.85	0.76	0.57	0.37	0.87	0.78	0.59	0.38	0.90	0.80	0.61	0.39	0.93	0.83	0.63	0.40	0.94	0.84	0.63	0.41	
	ΔT	19	18	14	10	19	18	15	10	19	18	15	10	19	18	15	10	19	18	14	10	18	17	14	9		
	1200	kW	2.14	2.18	2.25	2.33	2.31	2.36	2.43	2.51	2.45	2.51	2.59	2.68	2.58	2.64	2.73	2.82	2.69	2.76	2.85	2.95	2.79	2.85	2.95	3.05	
		Amps	8.1	8.3	8.6	8.9	8.8	9.0	9.3	9.6	9.5	9.7	10.0	10.4	10.1	10.4	10.7	11.1	10.8	11.1	11.4	11.9	11.4	11.7	12.1	12.6	
	1043	MBh	17	15	12	-	17	15	12	-	18	15	12	-	18	16	12	-	18	15	12	-	17	14	11	-	
		S/T	0.66	0.55	0.38	-	0.68	0.57	0.40	-	0.70	0.59	0.41	-	0.72	0.61	0.42	-	0.75	0.63	0.44	-	0.76	0.63	0.44	-	
	70	1356	MBh	34.5	35.5	38.4	41.2	33.7	34.7	37.5	40.3	32.9	33.8	36.6	39.3	32.1	33.0	35.7	38.4	30.5	31.4	34.0	36.4	28.2	29.1	31.5	33.8
			S/T	0.82	0.73	0.55	0.36	0.85	0.76	0.57	0.37	0.87	0.78	0.59	0.38	0.90	0.80	0.61	0.39	0.93	0.83	0.63	0.40	0.94	0.84	0.63	0.41
		ΔT	19	18	14	10	19	18	15	10	19	18	15	10	19	18	15	10	19	18	14	10	18	17	14	9	
		1200	kW	2.14	2.18	2.25	2.33	2.31	2.36	2.43	2.51	2.45	2.51	2.59	2.68	2.58	2.64	2.73	2.82	2.69	2.76	2.85	2.95	2.79	2.85	2.95	3.03
			Amps	8.0	8.2	8.5	8.8	8.7	8.9	9.2	9.5	9.4	9.6	9.9	10.2	10.0	10.2	10.5	10.8	10.6	10.9	11.2	11.5	11.2	11.5	11.9	12.3
1043		MBh	17	15	12	-	17	15	12	-	18	15	12	-	18	16	12	-	18	15	12	-	17	14	11	-	
		S/T	0.66	0.55	0.38	-	0.68	0.57	0.40	-	0.70	0.59	0.41	-	0.72	0.61	0.42	-	0.75	0.63	0.44	-	0.76	0.63	0.44	-	

IDB = Entering Indoor Dry Bulb Temperature
 High and low pressures are measured at the liquid and suction service valves.
 Shaded area reflects ACCA (TVA) conditions
 Amps = outdoor unit amps (comp.+fan)
 kW = Total system power

EXPANDED COOLING DATA — ASXC160361** / CA*F3743*6A* +TXV / MBVC1600** HIGH STAGE (CONT.)

IDB	AIRFLOW	OUTDOOR AMBIENT TEMPERATURE												ENTERING INDOOR WET BULB TEMPERATURE											
		65°F				75°F				85°F				95°F				105°F				115°F			
		59	63	67	71	59	63	67	71	59	63	67	71	59	63	67	71	59	63	67	71	59	63	67	71
80	MBh	35.1	35.9	38.3	41.0	34.3	35.0	37.4	40.0	33.5	34.2	36.5	39.0	32.6	33.4	35.6	38.1	31.0	31.7	33.9	36.2	28.7	29.4	31.4	33.5
	S/T	0.90	0.84	0.68	0.51	0.93	0.87	0.71	0.53	0.95	0.89	0.73	0.54	1.00	0.92	0.75	0.56	1.00	0.96	0.78	0.58	1.00	0.96	0.78	0.59
	ΔT	21	20	18	14	22	21	18	14	22	21	18	14	22	21	18	14	21	21	19	15	21	19	17	13
	kW	2.14	2.18	2.25	2.33	2.31	2.36	2.43	2.51	2.45	2.51	2.59	2.68	2.58	2.64	2.73	2.82	2.69	2.76	2.85	2.95	2.79	2.85	2.95	3.05
	Amps	8.1	8.3	8.6	8.9	8.8	9.0	9.3	9.6	9.5	9.7	10.0	10.4	10.1	10.4	10.7	11.1	10.8	11.1	11.4	11.9	11.4	11.7	12.1	12.6
	HI PR	232	249	253	259	262	282	286	292	298	321	325	332	340	365	370	379	367	394	400	409	435	467	474	484
	Lo PR	116	120	131	139	119	123	135	143	124	127	139	148	127	131	143	152	129	133	146	155	133	137	149	159
	MBh	34.1	34.8	37.2	39.8	33.3	34.0	36.3	38.8	32.5	33.2	35.5	37.9	31.7	32.4	34.6	37.0	30.1	30.8	32.9	35.1	27.9	28.5	30.4	32.5
	S/T	0.85	0.80	0.65	0.49	0.88	0.83	0.68	0.50	0.91	0.85	0.69	0.52	0.94	0.88	0.71	0.53	0.97	0.91	0.74	0.55	0.98	0.92	0.75	0.56
	ΔT	22	21	19	15	23	22	19	15	23	22	19	15	23	22	19	15	23	22	19	15	21	20	17	14
kW	2.12	2.17	2.24	2.31	2.29	2.34	2.41	2.49	2.43	2.49	2.57	2.66	2.56	2.62	2.71	2.80	2.67	2.73	2.82	2.92	2.77	2.83	2.93	3.03	
Amps	8.0	8.2	8.5	8.8	8.7	8.9	9.2	9.5	9.4	9.6	10.0	10.3	10.1	10.3	10.6	11.0	10.7	11.0	11.3	11.7	11.3	11.6	12.0	12.4	
HI PR	230	247	250	256	260	279	283	289	295	317	322	329	336	362	367	375	363	390	396	405	430	463	469	480	
Lo PR	115	119	129	138	118	122	133	142	122	126	138	147	126	130	141	151	128	132	144	154	131	135	148	157	
MBh	31.4	32.1	34.3	36.7	30.7	31.4	33.5	35.8	30.0	30.6	32.7	35.0	29.3	29.9	31.9	34.1	27.8	28.4	30.3	32.4	25.7	26.3	28.1	30.0	
S/T	0.82	0.77	0.63	0.47	0.85	0.80	0.65	0.49	0.87	0.82	0.67	0.50	0.90	0.85	0.69	0.52	0.94	0.88	0.72	0.53	0.95	0.89	0.72	0.54	
ΔT	23	22	19	15	23	22	19	15	23	22	19	15	23	22	19	16	23	22	19	15	21	21	18	14	
kW	2.10	2.15	2.22	2.29	2.27	2.32	2.39	2.47	2.41	2.47	2.55	2.63	2.54	2.60	2.68	2.78	2.65	2.71	2.80	2.90	2.74	2.81	2.90	3.00	
Amps	8.0	8.2	8.4	8.7	8.6	8.8	9.1	9.4	9.3	9.6	9.9	10.2	10.0	10.2	10.5	10.9	10.6	10.9	11.2	11.6	11.2	11.5	11.9	12.3	
HI PR	227	244	248	253	257	276	280	286	292	314	319	326	333	358	363	371	360	387	392	401	426	458	465	475	
Lo PR	114	117	128	136	117	121	132	140	121	125	136	145	124	128	140	149	127	131	143	152	130	134	146	156	

85	MBh	35.7	36.4	38.1	40.7	34.9	35.6	37.2	39.7	34.0	34.7	36.3	38.8	33.2	33.9	35.5	37.8	31.6	32.2	33.7	35.9	29.2	29.8	31.2	33.3
	S/T	0.94	0.91	0.82	0.66	0.97	0.94	0.85	0.69	1.00	0.96	0.87	0.70	1.00	0.99	0.90	0.73	1.00	1.00	0.93	0.75	1.00	1.00	0.94	0.76
	ΔT	23	22	21	18	23	23	21	19	23	23	21	19	23	23	22	19	21	22	21	18	20	20	20	17
	kW	2.14	2.18	2.25	2.33	2.31	2.36	2.43	2.51	2.45	2.51	2.59	2.68	2.58	2.64	2.73	2.82	2.69	2.76	2.85	2.95	2.79	2.85	2.95	3.05
	Amps	8.1	8.3	8.6	8.9	8.8	9.0	9.3	9.6	9.5	9.7	10.0	10.4	10.1	10.4	10.7	11.1	10.8	11.1	11.4	11.9	11.4	11.7	12.1	12.6
	HI PR	232	249	253	259	262	282	286	292	298	321	325	332	340	365	370	379	367	394	400	409	435	467	474	484
	Lo PR	116	120	131	139	119	123	135	143	124	127	139	148	127	131	143	152	129	133	146	155	133	137	149	159
	MBh	34.7	35.3	37.0	39.5	33.9	34.5	36.1	38.6	33.1	33.7	35.3	37.6	32.2	32.9	34.4	36.7	30.6	31.2	32.7	34.9	28.4	28.9	30.3	32.3
	S/T	0.90	0.86	0.78	0.63	0.93	0.90	0.81	0.66	0.95	0.92	0.83	0.67	0.98	0.95	0.86	0.69	1.00	0.98	0.89	0.72	1.00	0.99	0.89	0.73
	ΔT	24	23	22	19	24	24	22	19	24	24	22	19	24	24	23	20	23	24	22	19	22	22	21	18
kW	2.12	2.17	2.24	2.31	2.29	2.34	2.41	2.49	2.43	2.49	2.57	2.66	2.56	2.62	2.71	2.80	2.67	2.73	2.82	2.92	2.77	2.83	2.93	3.03	
Amps	8.0	8.2	8.5	8.8	8.7	8.9	9.2	9.5	9.4	9.6	10.0	10.3	10.1	10.3	10.6	11.0	10.7	11.0	11.3	11.7	11.3	11.6	12.0	12.4	
HI PR	230	247	250	256	260	279	283	289	295	317	322	329	336	362	367	375	363	390	396	405	430	463	469	480	
Lo PR	115	119	129	138	118	122	133	142	122	126	138	147	126	130	141	151	128	132	144	154	131	135	148	157	
MBh	32.0	32.6	34.2	36.4	31.3	31.9	33.4	35.6	30.5	31.1	32.6	34.7	29.8	30.3	31.8	33.9	28.3	28.8	30.2	32.2	26.2	26.7	28.0	29.8	
S/T	0.86	0.83	0.75	0.61	0.89	0.86	0.78	0.63	0.92	0.89	0.80	0.65	0.95	0.91	0.82	0.67	0.98	0.95	0.86	0.69	0.99	0.96	0.86	0.70	
ΔT	24	24	23	20	25	24	23	20	25	24	23	20	25	24	23	20	24	24	23	20	23	23	21	18	
kW	2.10	2.15	2.22	2.29	2.27	2.32	2.39	2.47	2.41	2.47	2.55	2.63	2.54	2.60	2.68	2.78	2.65	2.71	2.80	2.90	2.74	2.81	2.90	3.00	
Amps	8.0	8.2	8.4	8.7	8.6	8.8	9.1	9.4	9.3	9.6	9.9	10.2	10.0	10.2	10.5	10.9	10.6	10.9	11.2	11.6	11.2	11.5	11.9	12.3	
HI PR	227	244	248	253	257	276	280	286	292	314	319	326	333	358	363	371	360	387	392	401	426	458	465	475	
Lo PR	114	117	128	136	117	121	132	140	121	125	136	145	124	128	140	149	127	131	143	152	130	134	146	156	

IDB = Entering Indoor Dry Bulb Temperature
 High and low pressures are measured at the liquid and suction service valves.
 Shaded area reflects AHR1 (TVA) conditions
 Amps = outdoor unit amps (comp.+fan)
 kW = Total system power

EXPANDED COOLING DATA — ASXC160481A* / CA*F4961*6A* +TXV / MBVC2000** Low STAGE (CONT.)

IDB	AIRFLOW	OUTDOOR AMBIENT TEMPERATURE												ENTERING INDOOR WET BULB TEMPERATURE											
		65°F				75°F				85°F				95°F				105°F				115°F			
		59	63	67	71	59	63	67	71	59	63	67	71	59	63	67	71	59	63	67	71	59	63	67	71
80	MBh	35.1	35.9	38.3	41.0	34.3	35.0	37.4	40.0	33.5	34.2	36.5	39.1	32.7	33.4	35.6	38.1	31.0	31.7	33.9	36.2	28.7	29.4	31.4	33.5
	S/T	0.91	0.86	0.70	0.52	0.95	0.89	0.72	0.54	1.00	0.91	0.74	0.55	1.00	0.94	0.77	0.57	1.00	1.00	0.79	0.59	1.00	1.00	0.80	0.60
	ΔT	24	23	20	16	24	23	20	16	24	23	20	16	24	23	20	16	23	24	22	19	21	22	19	15
	kW	2.04	2.09	2.16	2.23	2.21	2.26	2.33	2.41	2.35	2.41	2.49	2.57	2.48	2.54	2.62	2.71	2.59	2.65	2.74	2.83	2.68	2.74	2.84	2.94
	Amps	8.1	8.3	8.6	8.9	8.8	9.0	9.3	9.6	9.5	9.7	10.0	10.4	10.1	10.4	10.7	11.1	10.8	11.0	11.4	11.8	11.4	11.7	12.1	12.5
	HI PR	227	244	248	253	257	276	280	286	292	314	318	325	332	357	362	370	374	402	408	417	419	450	457	467
	Lo PR	122	125	137	146	125	129	141	150	129	134	146	155	133	137	150	159	136	140	153	163	139	143	156	167
	MBh	34.1	34.8	37.2	39.8	33.3	34.0	36.3	38.8	32.5	33.2	35.5	37.9	31.7	32.4	34.6	37.0	30.1	30.8	32.9	35.1	27.9	28.5	30.5	32.6
	S/T	0.87	0.82	0.67	0.50	0.90	0.85	0.69	0.52	0.93	0.87	0.71	0.53	0.96	0.90	0.73	0.55	0.99	0.93	0.76	0.57	1.00	0.94	0.76	0.57
	ΔT	25	24	21	17	25	24	21	17	25	24	21	17	25	24	21	17	25	24	21	17	23	22	19	16
kW	2.03	2.07	2.14	2.21	2.19	2.24	2.31	2.39	2.33	2.38	2.47	2.55	2.46	2.51	2.60	2.69	2.57	2.62	2.71	2.81	2.66	2.72	2.81	2.91	
Amps	8.1	8.2	8.5	8.8	8.7	8.9	9.2	9.5	9.4	9.6	10.0	10.3	10.1	10.3	10.6	11.0	10.7	10.9	11.3	11.7	11.3	11.6	12.0	12.4	
HI PR	225	242	245	251	254	273	277	283	289	311	315	322	329	354	359	367	370	398	404	413	415	446	452	462	
Lo PR	120	124	136	144	124	128	140	149	128	132	144	154	132	136	148	158	134	138	151	161	138	142	155	165	
MBh	31.5	32.1	34.3	36.7	30.7	31.4	33.5	35.9	30.0	30.6	32.7	35.0	29.3	29.9	31.9	34.1	27.8	28.4	30.3	32.4	25.8	26.3	28.1	30.1	
S/T	0.84	0.79	0.64	0.48	0.87	0.82	0.66	0.50	0.89	0.84	0.68	0.51	0.92	0.86	0.70	0.53	0.96	0.90	0.73	0.55	0.96	0.90	0.74	0.55	
ΔT	25	24	21	17	26	25	21	17	26	25	21	17	26	25	21	17	26	25	21	17	24	23	20	16	
kW	2.01	2.05	2.12	2.19	2.17	2.22	2.29	2.37	2.31	2.36	2.44	2.53	2.44	2.49	2.58	2.67	2.54	2.60	2.69	2.78	2.64	2.70	2.79	2.89	
Amps	8.0	8.2	8.4	8.7	8.6	8.8	9.1	9.4	9.3	9.6	9.9	10.2	10.0	10.2	10.5	10.9	10.6	10.8	11.2	11.6	11.2	11.5	11.9	12.3	
HI PR	223	239	243	248	252	270	274	280	286	308	312	319	326	350	355	363	367	394	400	409	411	441	448	458	
Lo PR	119	123	134	143	123	127	138	147	127	131	143	152	130	134	147	156	133	137	150	159	136	140	153	163	

85	MBh	35.7	36.4	38.1	40.7	34.9	35.6	37.2	39.7	34.1	34.7	36.4	38.8	33.2	33.9	35.5	37.8	31.6	32.2	33.7	35.9	29.2	29.8	31.2	33.3
	S/T	0.96	0.92	0.83	0.68	0.99	0.96	0.86	0.70	1.00	0.98	0.89	0.72	1.00	1.00	0.92	0.74	1.00	1.00	0.95	0.77	1.00	1.00	0.96	0.78
	ΔT	25	25	24	20	26	25	24	21	25	25	24	21	25	25	24	21	23	24	24	21	22	22	22	19
	kW	2.04	2.09	2.16	2.23	2.21	2.26	2.33	2.41	2.35	2.41	2.49	2.57	2.48	2.54	2.62	2.71	2.59	2.65	2.74	2.83	2.68	2.74	2.84	2.94
	Amps	8.1	8.3	8.6	8.9	8.8	9.0	9.3	9.6	9.5	9.7	10.0	10.4	10.1	10.4	10.7	11.1	10.8	11.0	11.4	11.8	11.4	11.7	12.1	12.5
	HI PR	227	244	248	253	257	276	280	286	292	314	318	325	332	357	362	370	374	402	408	417	419	450	457	467
	Lo PR	122	125	137	146	125	129	141	150	129	134	146	155	133	137	150	159	136	140	153	163	139	143	156	167
	MBh	34.7	35.3	37.0	39.5	33.9	34.5	36.2	38.6	33.1	33.7	35.3	37.7	32.3	32.9	34.4	36.7	30.6	31.2	32.7	34.9	28.4	28.9	30.3	32.3
	S/T	0.91	0.88	0.80	0.65	0.95	0.91	0.82	0.67	0.97	0.94	0.85	0.69	1.00	0.97	0.87	0.71	1.00	1.00	0.91	0.73	1.00	1.00	0.91	0.74
	ΔT	26	26	25	21	27	26	25	22	27	26	25	22	27	27	25	22	26	26	25	21	24	24	23	20
kW	2.03	2.07	2.14	2.21	2.19	2.24	2.31	2.39	2.33	2.38	2.47	2.55	2.46	2.51	2.60	2.69	2.57	2.62	2.71	2.81	2.66	2.72	2.81	2.91	
Amps	8.1	8.2	8.5	8.8	8.7	8.9	9.2	9.5	9.4	9.6	10.0	10.3	10.1	10.3	10.6	11.0	10.7	10.9	11.3	11.7	11.3	11.6	12.0	12.4	
HI PR	225	242	245	251	254	273	277	283	289	311	315	322	329	354	359	367	370	398	404	413	415	446	452	462	
Lo PR	120	124	136	144	124	128	140	149	128	132	144	154	132	136	148	158	134	138	151	161	138	142	155	165	
MBh	32.0	32.6	34.2	36.5	31.3	31.9	33.4	35.6	30.5	31.1	32.6	34.8	29.8	30.3	31.8	33.9	28.3	28.8	30.2	32.2	26.2	26.7	28.0	29.8	
S/T	0.88	0.85	0.77	0.62	0.91	0.88	0.80	0.65	0.94	0.90	0.82	0.66	0.97	0.93	0.84	0.68	1.00	0.97	0.87	0.71	1.00	0.98	0.88	0.71	
ΔT	26.9	26	25	22	27	27	25	22	27	27	25	22	27	27	26	22	27	27	25	22	25	25	24	20	
kW	2.01	2.05	2.12	2.19	2.17	2.22	2.29	2.37	2.31	2.36	2.44	2.53	2.44	2.49	2.58	2.67	2.54	2.60	2.69	2.78	2.64	2.70	2.79	2.89	
Amps	8.0	8.2	8.4	8.7	8.6	8.8	9.1	9.4	9.3	9.6	9.9	10.2	10.0	10.2	10.5	10.9	10.6	10.8	11.2	11.6	11.2	11.5	11.9	12.3	
HI PR	223	239	243	248	252	270	274	280	286	308	312	319	326	350	355	363	367	394	400	409	411	441	448	458	
Lo PR	119	123	134	143	123	127	138	147	127	131	143	152	130	134	147	156	133	137	150	159	136	140	153	163	

IDB = Entering Indoor Dry Bulb Temperature
 High and low pressures are measured at the liquid and suction service valves.
 Shaded area reflects AHR1 (TVA) conditions
 Amps = outdoor unit amps (comp.+fan)
 kW = Total system power

EXPANDED COOLING DATA — ASXC160481A* / CA*F4961*6A* +TXV / MBVC2000** HIGH STAGE

IDB	AIRFLOW	OUTDOOR AMBIENT TEMPERATURE																							
		65°F				75°F				85°F				95°F				105°F				115°F			
		59	63	67	71	59	63	67	71	59	63	67	71	59	63	67	71	59	63	67	71	59	63	67	71
70	MBh	46.1	47.7	52.3	-	45.0	46.6	51.1	-	43.9	45.5	49.9	-	42.8	44.4	48.7	-	40.7	42.2	46.2	-	37.7	39.1	42.8	-
	S/T	0.77	0.64	0.44	-	0.80	0.66	0.46	-	0.82	0.68	0.47	-	0.84	0.70	0.49	-	0.87	0.73	0.51	-	0.88	0.74	0.51	-
	ΔT	19	16	12	-	19	16	12	-	19	16	12	-	19	16	12	-	19	16	12	-	18	15	12	-
	kW	2.94	3.01	3.10	-	3.18	3.25	3.36	-	3.38	3.46	3.58	-	3.57	3.65	3.77	-	3.72	3.81	3.94	-	3.86	3.95	4.08	-
	Amps	11.4	11.7	12.1	-	12.3	12.6	13.0	-	13.4	13.7	14.2	-	14.3	14.7	15.2	-	15.2	15.6	16.1	-	16.1	16.5	17.1	-
	HI PR	241	259	262	-	272	292	297	-	309	333	337	-	352	379	384	-	396	426	432	-	444	477	484	-
	Lo PR	120	124	135	-	123	127	139	-	127	131	144	-	131	135	147	-	133	138	150	-	137	141	154	-
	MBh	44.7	46.3	50.8	-	43.7	45.3	49.6	-	42.6	44.2	48.4	-	41.6	43.1	47.2	-	39.5	41.0	44.9	-	36.6	37.9	41.6	-
	S/T	0.73	0.61	0.42	-	0.76	0.63	0.44	-	0.78	0.65	0.45	-	0.80	0.67	0.46	-	0.83	0.70	0.48	-	0.84	0.70	0.49	-
	ΔT	19	17	13	-	20	17	13	-	20	17	13	-	20	17	13	-	20	17	13	-	18	16	12	-
	kW	2.92	2.98	3.08	-	3.15	3.22	3.33	-	3.36	3.43	3.55	-	3.54	3.62	3.74	-	3.69	3.78	3.91	-	3.83	3.91	4.05	-
	Amps	11.3	11.6	12.0	-	12.2	12.5	12.9	-	13.3	13.6	14.0	-	14.2	14.5	15.0	-	15.1	15.5	16.0	-	16.0	16.4	16.9	-
HI PR	238	256	260	-	269	289	294	-	306	329	334	-	349	375	380	-	392	422	428	-	439	472	479	-	
Lo PR	119	122	133	-	122	126	137	-	126	130	142	-	130	134	146	-	132	136	149	-	135	140	152	-	
MBh	41.3	42.8	46.9	-	40.3	41.8	45.8	-	39.4	40.8	44.7	-	38.4	39.8	43.6	-	36.5	37.8	41.4	-	33.8	35.0	38.4	-	
S/T	0.71	0.59	0.41	-	0.73	0.61	0.42	-	0.75	0.63	0.43	-	0.77	0.65	0.45	-	0.80	0.67	0.46	-	0.81	0.68	0.47	-	
ΔT	20	17	13	-	20	17	13	-	20	17	13	-	20	17	13	-	20	17	13	-	19	16	12	-	
kW	2.89	2.96	3.05	-	3.12	3.19	3.30	-	3.33	3.40	3.52	-	3.51	3.59	3.71	-	3.66	3.74	3.87	-	3.79	3.88	4.01	-	
Amps	11.2	11.5	11.8	-	12.1	12.4	12.8	-	13.2	13.5	13.9	-	14.1	14.4	14.9	-	15.0	15.3	15.8	-	15.9	16.2	16.8	-	
HI PR	236	254	257	-	267	287	291	-	303	326	331	-	345	371	376	-	388	418	424	-	435	468	474	-	
Lo PR	117	121	132	-	121	125	136	-	125	129	141	-	128	132	144	-	131	135	147	-	134	138	151	-	

75	MBh	46.8	48.2	52.2	56.0	45.7	47.1	51.0	54.7	44.7	46.0	49.8	53.4	43.6	44.9	48.6	52.1	41.4	42.6	46.1	49.5	38.3	39.5	42.7	45.9
	S/T	0.87	0.78	0.59	0.38	0.90	0.81	0.61	0.39	0.93	0.83	0.63	0.40	0.96	0.86	0.65	0.42	0.99	0.89	0.67	0.43	1.00	0.90	0.68	0.44
	ΔT	22	20	16	11	22	20	16	11	22	20	16	11	22	20	17	11	22	20	16	11	20	19	15	11
	kW	2.94	3.01	3.10	3.21	3.18	3.25	3.36	3.47	3.38	3.46	3.58	3.70	3.57	3.65	3.77	3.90	3.72	3.81	3.94	4.08	3.86	3.95	4.08	4.23
	Amps	11.4	11.7	12.1	12.5	12.3	12.6	13.0	13.5	13.4	13.7	14.2	14.7	14.3	14.7	15.2	15.7	15.2	15.6	16.1	16.8	16.1	16.5	17.1	17.8
	HI PR	241	259	262	268	272	292	297	303	309	333	337	345	352	379	384	393	396	426	432	442	444	477	484	495
	Lo PR	120	124	135	144	123	127	139	148	127	131	144	153	131	135	147	157	133	138	150	160	137	141	154	164
	MBh	45.5	46.8	50.7	54.4	44.4	45.7	49.5	53.1	43.4	44.6	48.3	51.9	42.3	43.6	47.1	50.6	40.2	41.4	44.8	48.1	37.2	38.3	41.5	44.5
	S/T	0.83	0.74	0.56	0.36	0.86	0.77	0.58	0.38	0.88	0.79	0.60	0.39	0.91	0.82	0.62	0.40	0.95	0.85	0.64	0.41	0.96	0.85	0.65	0.42
	ΔT	22	21	17	12	23	21	17	12	23	21	17	12	23	21	17	12	23	21	17	12	21	19	16	11
	kW	2.92	2.98	3.08	3.18	3.15	3.22	3.33	3.44	3.36	3.43	3.55	3.67	3.54	3.62	3.74	3.87	3.69	3.78	3.91	4.04	3.83	3.91	4.05	4.19
	Amps	11.3	11.6	12.0	12.4	12.2	12.5	12.9	13.4	13.3	13.6	14.0	14.6	14.2	14.5	15.0	15.6	15.1	15.5	16.0	16.6	16.0	16.4	16.9	17.6
HI PR	238	256	260	265	269	289	294	300	306	329	334	341	349	375	380	389	392	422	428	437	439	472	479	490	
Lo PR	119	122	133	142	122	126	137	146	126	130	142	151	130	134	146	155	132	136	149	158	135	140	152	162	
MBh	42.0	43.2	46.8	50.2	41.0	42.2	45.7	49.0	40.0	41.2	44.6	47.9	39.0	40.2	43.5	46.7	37.1	38.2	41.3	44.4	34.4	35.4	38.3	41.1	
S/T	0.80	0.72	0.54	0.35	0.83	0.74	0.56	0.36	0.85	0.76	0.58	0.37	0.88	0.79	0.60	0.38	0.91	0.82	0.62	0.40	0.92	0.82	0.62	0.40	
ΔT	23	21	17	12	23	21	17	12	23	21	17	12	23	21	18	12	23	21	17	12	21	20	16	11	
kW	2.89	2.96	3.05	3.16	3.12	3.19	3.30	3.41	3.33	3.40	3.52	3.64	3.51	3.59	3.71	3.84	3.66	3.74	3.87	4.01	3.79	3.88	4.01	4.15	
Amps	11.2	11.5	11.8	12.3	12.1	12.4	12.8	13.3	13.2	13.5	13.9	14.4	14.1	14.4	14.9	15.4	15.0	15.3	15.8	16.4	15.9	16.2	16.8	17.4	
HI PR	236	254	257	263	267	287	291	297	303	326	331	338	345	371	376	385	388	418	424	433	435	468	474	485	
Lo PR	117	121	132	141	121	125	136	145	125	129	141	150	128	132	144	154	131	135	147	157	134	138	151	161	

IDB = Entering Indoor Dry Bulb Temperature
 High and low pressures are measured at the liquid and suction service valves.
 Shaded area reflects ACCA (TVA) conditions
 Amps = outdoor unit amps (comp.+fan)
 kW = Total system power

EXPANDED COOLING DATA — ASXC160481A* / CA*F4961*6A* +TXV / MBVC2000** HIGH STAGE (CONT.)

IDB	AIRFLOW	OUTDOOR AMBIENT TEMPERATURE												ENTERING INDOOR WET BULB TEMPERATURE											
		65°F				75°F				85°F				95°F				105°F				115°F			
		59	63	67	71	59	63	67	71	59	63	67	71	59	63	67	71	59	63	67	71	59	63	67	71
80	MBh	47.7	48.7	52.0	55.6	46.6	47.6	50.8	54.3	45.5	46.4	49.6	53.0	44.3	45.3	48.4	51.8	42.1	43.0	46.0	49.2	39.0	39.9	42.6	45.5
	S/T	0.96	0.90	0.73	0.55	1.00	0.93	0.76	0.57	1.00	0.95	0.78	0.58	1.00	1.00	0.80	0.60	1.00	1.00	0.83	0.62	1.00	1.00	0.84	0.63
	ΔT	24	23	20	16	25	23	20	16	24	23	20	16	23	24	20	16	22	24	20	16	21	21	19	15
	kW	2.94	3.01	3.10	3.21	3.18	3.25	3.36	3.47	3.38	3.46	3.58	3.70	3.57	3.65	3.77	3.90	3.72	3.81	3.94	4.08	3.86	3.95	4.08	4.23
	Amps	11.4	11.7	12.1	12.5	12.3	12.6	13.0	13.5	13.4	13.7	14.2	14.7	14.3	14.7	15.2	15.7	15.2	15.6	16.1	16.8	16.1	16.5	17.1	17.8
	HI PR	241	259	262	268	272	292	297	303	309	333	337	345	352	379	384	393	396	426	432	442	444	477	484	495
	Lo PR	120	124	135	144	123	127	139	148	127	131	144	153	131	135	147	157	133	138	150	160	137	141	154	164
	MBh	46.3	47.3	50.5	54.0	45.2	46.2	49.4	52.8	44.1	45.1	48.2	51.5	43.1	44.0	47.0	50.2	40.9	41.8	44.7	47.7	37.9	38.7	41.4	44.2
	S/T	0.91	0.86	0.70	0.52	0.95	0.89	0.72	0.54	0.97	0.91	0.74	0.55	1.00	0.94	0.76	0.57	1.00	0.97	0.79	0.59	1.00	0.98	0.80	0.60
	ΔT	25	24	21	17	25	24	21	17	25	24	21	17	26	24	21	17	24	24	21	17	22	23	20	16
kW	2.92	2.98	3.08	3.18	3.15	3.22	3.33	3.44	3.36	3.43	3.55	3.67	3.54	3.62	3.74	3.87	3.69	3.78	3.91	4.04	3.83	3.91	4.05	4.19	
Amps	11.3	11.6	12.0	12.4	12.2	12.5	12.9	13.4	13.3	13.6	14.0	14.6	14.2	14.5	15.0	15.6	15.1	15.5	16.0	16.6	16.0	16.4	16.9	17.6	
HI PR	238	256	260	265	269	289	294	300	306	329	334	341	349	375	380	389	392	422	428	437	439	472	479	490	
Lo PR	119	122	133	142	122	126	137	146	126	130	142	151	130	134	146	155	132	136	149	158	135	140	152	162	
MBh	42.7	43.6	46.6	49.9	41.7	42.6	45.6	48.7	40.7	41.6	44.5	47.5	39.7	40.6	43.4	46.4	37.8	38.6	41.2	44.1	35.0	35.7	38.2	40.8	
S/T	0.88	0.83	0.67	0.50	0.91	0.86	0.70	0.52	0.93	0.88	0.71	0.53	0.97	0.91	0.74	0.55	1.00	0.94	0.76	0.57	1.01	0.95	0.77	0.58	
ΔT	25	24	21	17	26	25	21	17	26	25	22	17	26	25	22	17	26	25	21	17	24	23	20	16	
kW	2.89	2.96	3.05	3.16	3.12	3.19	3.30	3.41	3.33	3.40	3.52	3.64	3.51	3.59	3.71	3.84	3.66	3.74	3.87	4.01	3.79	3.88	4.01	4.15	
Amps	11.2	11.5	11.8	12.3	12.1	12.4	12.8	13.3	13.2	13.5	13.9	14.4	14.1	14.4	14.9	15.4	15.0	15.3	15.8	16.4	15.9	16.2	16.8	17.4	
HI PR	236	254	257	263	267	287	291	297	303	326	331	338	345	371	376	385	388	418	424	433	435	468	474	485	
Lo PR	117	121	132	141	121	125	136	145	125	129	141	150	128	132	144	154	131	135	147	157	134	138	151	161	

85	MBh	48.5	49.4	51.8	55.2	47.4	48.3	50.6	54.0	46.2	47.1	49.4	52.7	45.1	46.0	48.2	51.4	42.9	43.7	45.8	48.8	39.7	40.5	42.4	45.2
	S/T	1.00	0.97	0.87	0.71	1.00	1.00	0.91	0.73	1.00	1.00	0.93	0.75	1.00	1.00	0.96	0.78	1.00	1.00	0.99	0.81	1.00	1.00	1.00	0.81
	ΔT	26	25	24	21	25	25	24	21	24	25	24	21	24	24	24	21	23	23	24	21	21	21	22	19
	kW	2.94	3.01	3.10	3.21	3.18	3.25	3.36	3.47	3.38	3.46	3.58	3.70	3.57	3.65	3.77	3.90	3.72	3.81	3.94	4.08	3.86	3.95	4.08	4.23
	Amps	11.4	11.7	12.1	12.5	12.3	12.6	13.0	13.5	13.4	13.7	14.2	14.7	14.3	14.7	15.2	15.7	15.2	15.6	16.1	16.8	16.1	16.5	17.1	17.8
	HI PR	241	259	262	268	272	292	297	303	309	333	337	345	352	379	384	393	396	426	432	442	444	477	484	495
	Lo PR	120	124	135	144	123	127	139	148	127	131	144	153	131	135	147	157	133	138	150	160	137	141	154	164
	MBh	47.1	48.0	50.3	53.6	46.0	46.9	49.1	52.4	44.9	45.8	47.9	51.1	43.8	44.7	46.8	49.9	41.6	42.4	44.4	47.4	38.5	39.3	41.2	43.9
	S/T	0.96	0.92	0.83	0.68	0.99	0.96	0.86	0.70	1.00	0.98	0.89	0.72	1.00	1.00	0.91	0.74	1.00	1.00	0.95	0.77	1.00	1.00	0.96	0.78
	ΔT	27	26	25	21	27	27	25	22	27	27	25	22	26	26	25	22	25	25	25	22	23	23	23	20
kW	2.92	2.98	3.08	3.18	3.15	3.22	3.33	3.44	3.36	3.43	3.55	3.67	3.54	3.62	3.74	3.87	3.69	3.78	3.91	4.04	3.83	3.91	4.05	4.19	
Amps	11.3	11.6	12.0	12.4	12.2	12.5	12.9	13.4	13.3	13.6	14.0	14.6	14.2	14.5	15.0	15.6	15.1	15.5	16.0	16.6	16.0	16.4	16.9	17.6	
HI PR	238	256	260	265	269	289	294	300	306	329	334	341	349	375	380	389	392	422	428	437	439	472	479	490	
Lo PR	119	122	133	142	122	126	137	146	126	130	142	151	130	134	146	155	132	136	149	158	135	140	152	162	
MBh	43.5	44.3	46.4	49.5	42.5	43.3	45.3	48.4	41.4	42.2	44.2	47.2	40.4	41.2	43.2	46.0	38.4	39.2	41.0	43.7	35.6	36.3	38.0	40.5	
S/T	0.92	0.89	0.80	0.65	0.96	0.92	0.83	0.68	0.98	0.95	0.85	0.69	1.00	0.98	0.88	0.71	1.00	1.00	0.91	0.74	1.00	1.00	0.92	0.75	
ΔT	27	27	25	22	28	27	26	22	28	27	26	22	27	27	26	22	26	27	25	22	24	25	24	21	
kW	2.89	2.96	3.05	3.16	3.12	3.19	3.30	3.41	3.33	3.40	3.52	3.64	3.51	3.59	3.71	3.84	3.66	3.74	3.87	4.01	3.79	3.88	4.01	4.15	
Amps	11.2	11.5	11.8	12.3	12.1	12.4	12.8	13.3	13.2	13.5	13.9	14.4	14.1	14.4	14.9	15.4	15.0	15.3	15.8	16.4	15.9	16.2	16.8	17.4	
HI PR	236	254	257	263	267	287	291	297	303	326	331	338	345	371	376	385	388	418	424	433	435	468	474	485	
Lo PR	117	121	132	141	121	125	136	145	125	129	141	150	128	132	144	154	131	135	147	157	134	138	151	161	

IDB = Entering Indoor Dry Bulb Temperature
 High and low pressures are measured at the liquid and suction service valves.
 Shaded area reflects AHRH (TVA) conditions
 Amps = outdoor unit amps (comp.+fan)
 kW = Total system power

EXPANDED COOLING DATA — ASXC160481B* / CA*F4860*6** +TXV/MBYC2000** LOW STAGE

IDB	AIRFLOW	OUTDOOR AMBIENT TEMPERATURE												ENTERING INDOOR WET BULB TEMPERATURE													
		65°F				75°F				85°F				95°F				105°F				115°F					
		59	63	67	71	59	63	67	71	59	63	67	71	59	63	67	71	59	63	67	71	59	63	67	71		
70	1238	MBh	34.3	35.5	38.9	-	33.5	34.7	38.0	-	32.7	33.9	37.1	-	31.9	33.1	36.2	-	30.3	31.4	34.4	-	28.1	29.1	31.9	-	
		S/T	0.74	0.62	0.43	-	0.77	0.64	0.45	-	0.79	0.66	0.46	-	0.82	0.68	0.47	-	0.85	0.71	0.49	-	0.85	0.71	0.49	-	
		ΔT	19	16	12	-	19	17	13	-	19	17	13	-	19	17	13	-	19	16	13	-	18	15	12	-	
	1100	kW	2.04	2.08	2.15	-	2.20	2.25	2.32	-	2.34	2.39	2.47	-	2.46	2.52	2.60	-	2.57	2.63	2.71	-	2.66	2.72	2.81	-	
		Amps	9.8	10.0	10.2	-	10.4	10.6	10.9	-	11.2	11.4	11.8	-	11.9	12.1	12.5	-	12.5	12.8	13.2	-	13.2	13.4	13.8	-	
		HI PR	216	232	245	-	242	261	275	-	275	296	313	-	314	337	356	-	353	380	401	-	390	419	443	-	
	963	LO PR	107	114	124	-	113	120	131	-	117	125	136	-	123	131	143	-	129	137	150	-	133	142	155	-	
		MBh	33.3	34.5	37.8	-	32.5	33.7	36.9	-	31.7	32.9	36.1	-	31.0	32.1	35.2	-	29.4	30.5	33.4	-	27.3	28.3	31.0	-	
		S/T	0.71	0.59	0.41	-	0.73	0.61	0.43	-	0.75	0.63	0.44	-	0.78	0.65	0.45	-	0.81	0.67	0.47	-	0.81	0.68	0.47	-	
	75	1238	ΔT	20	17	13	-	20	17	13	-	20	17	13	-	20	17	13	-	20	17	13	-	19	16	12	-
			kW	2.02	2.07	2.13	-	2.18	2.23	2.30	-	2.32	2.37	2.45	-	2.44	2.50	2.58	-	2.55	2.60	2.69	-	2.64	2.70	2.79	-
			Amps	9.7	9.9	10.2	-	10.4	10.6	10.9	-	11.1	11.3	11.7	-	11.8	12.0	12.4	-	12.4	12.7	13.0	-	13.1	13.3	13.7	-
963	HI PR	214	230	243	-	240	258	272	-	273	293	310	-	310	334	353	-	349	376	397	-	386	415	439	-		
	LO PR	106	112	123	-	112	119	130	-	116	123	135	-	122	130	142	-	128	136	148	-	132	141	153	-		
	MBh	30.7	31.9	34.9	-	30.0	31.1	34.1	-	29.3	30.4	33.3	-	28.6	29.6	32.5	-	27.2	28.2	30.8	-	25.2	26.1	28.6	-		
75	1100	S/T	0.68	0.57	0.40	-	0.71	0.59	0.41	-	0.73	0.61	0.42	-	0.75	0.63	0.43	-	0.78	0.65	0.45	-	0.78	0.66	0.45	-	
		ΔT	20	17	13	-	20	18	13	-	20	18	13	-	20	18	13	-	20	17	13	-	19	16	12	-	
		kW	1.97	2.02	2.08	-	2.13	2.17	2.24	-	2.26	2.31	2.39	-	2.38	2.43	2.51	-	2.48	2.54	2.62	-	2.57	2.63	2.71	-	
75	1238	Amps	9.5	9.7	9.9	-	10.1	10.3	10.6	-	10.8	11.1	11.4	-	11.5	11.7	12.1	-	12.1	12.4	12.7	-	12.7	13.0	13.4	-	
		HI PR	207	223	235	-	232	250	264	-	264	285	300	-	301	324	342	-	339	365	385	-	374	403	425	-	
		LO PR	102	109	119	-	108	115	126	-	113	120	131	-	118	126	137	-	124	132	144	-	128	136	149	-	
75	1238	MBh	34.9	35.9	38.9	41.7	34.1	35.1	38.0	40.7	33.3	34.2	37.1	39.8	32.4	33.4	36.2	38.8	30.8	31.7	34.4	36.9	28.6	29.4	31.8	34.2	
		S/T	0.84	0.76	0.57	0.37	0.88	0.78	0.59	0.38	0.90	0.80	0.61	0.39	0.93	0.83	0.63	0.40	0.96	0.86	0.65	0.42	0.97	0.87	0.66	0.42	
		ΔT	22	20	17	11	22	20	17	12	22	20	17	12	22	21	17	12	22	20	17	11	21	19	16	11	
	1100	kW	2.06	2.10	2.17	2.24	2.22	2.27	2.34	2.42	2.36	2.41	2.49	2.57	2.48	2.54	2.62	2.71	2.59	2.65	2.74	2.83	2.68	2.74	2.83	2.93	
		Amps	9.9	10.0	10.3	10.6	10.5	10.7	11.0	11.4	11.3	11.5	11.8	12.2	11.9	12.2	12.6	13.0	12.6	12.9	13.3	13.7	13.3	13.6	14.0	14.4	
		HI PR	218	235	248	258	245	263	278	290	278	299	316	330	317	341	360	375	356	383	405	422	394	424	447	467	
	963	LO PR	108	115	125	133	114	121	132	141	118	126	137	146	124	132	144	154	130	139	151	161	135	143	157	167	
		MBh	33.9	34.9	37.7	40.5	33.1	34.1	36.9	39.6	32.3	33.2	36.0	38.6	31.5	32.4	35.1	37.7	29.9	30.8	33.3	35.8	27.7	28.5	30.9	33.2	
		S/T	0.81	0.72	0.55	0.35	0.84	0.75	0.57	0.36	0.86	0.77	0.58	0.37	0.88	0.79	0.60	0.38	0.92	0.82	0.62	0.40	0.93	0.83	0.63	0.40	
	75	1100	ΔT	23	21	17	12	23	21	17	12	23	21	17	12	23	21	18	12	23	21	17	12	21	20	16	11
			kW	2.04	2.08	2.15	2.22	2.20	2.25	2.32	2.40	2.34	2.39	2.47	2.55	2.46	2.52	2.60	2.69	2.57	2.63	2.71	2.81	2.66	2.72	2.81	2.91
			Amps	9.8	10.0	10.2	10.6	10.4	10.6	10.9	11.3	11.2	11.4	11.8	12.1	11.9	12.1	12.5	12.9	12.5	12.8	13.2	13.6	13.2	13.4	13.8	14.3
963	HI PR	216	232	245	256	242	261	275	287	275	296	313	326	314	338	356	372	353	380	401	418	390	420	443	462		
	LO PR	107	114	124	132	113	120	131	139	117	125	136	145	123	131	143	152	129	137	150	160	133	142	155	165		
	MBh	31.3	32.2	34.8	37.4	30.5	31.4	34.0	36.5	29.8	30.7	33.2	35.6	29.1	29.9	32.4	34.8	27.6	28.4	30.8	33.0	25.6	26.3	28.5	30.6		
75	1100	S/T	0.78	0.69	0.53	0.34	0.81	0.72	0.55	0.35	0.83	0.74	0.56	0.36	0.85	0.76	0.58	0.37	0.88	0.79	0.60	0.39	0.89	0.80	0.60	0.39	
		ΔT	23	21	17	12	23	22	18	12	24	22	18	12	24	22	18	12	24	22	18	12	22	20	16	11	
		kW	1.99	2.03	2.10	2.17	2.14	2.19	2.26	2.34	2.28	2.33	2.41	2.49	2.40	2.45	2.54	2.62	2.50	2.56	2.64	2.73	2.59	2.65	2.74	2.83	
963	Amps	9.6	9.7	10.0	10.3	10.2	10.4	10.7	11.0	10.9	11.2	11.5	11.8	11.6	11.8	12.2	12.6	12.2	12.5	12.8	13.3	12.8	13.1	13.5	14.0		
	HI PR	209	225	238	248	235	253	267	278	267	287	304	317	304	327	346	361	342	368	389	406	378	407	430	448		
	LO PR	104	110	120	128	109	116	127	135	114	121	132	141	119	127	139	148	125	133	145	155	129	138	150	160		

IDB = Entering Indoor Dry Bulb Temperature
 High and low pressures are measured at the liquid and suction service valves.
 Shaded area reflects ACCA (TVA) conditions
 kW = Total system power
 Amps = outdoor unit amps (comp. +fan)

EXPANDED COOLING DATA — ASXC160481B* / CA*F4860*6** +TXV/MBVC2000** Low STAGE (CONT.)

IDB	AIRFLOW	OUTDOOR AMBIENT TEMPERATURE												ENTERING INDOOR WET BULB TEMPERATURE											
		65°F				75°F				85°F				95°F				105°F				115°F			
		59	63	67	71	59	63	67	71	59	63	67	71	59	63	67	71	59	63	67	71	59	63	67	71
80	MBh	35.5	36.3	38.8	41.4	34.7	35.4	37.9	40.5	33.8	34.6	37.0	39.5	33.0	33.7	36.1	38.5	31.4	32.1	34.2	36.6	29.1	29.7	31.7	33.9
	S/T	0.93	0.87	0.71	0.53	0.96	0.90	0.73	0.55	1.00	0.92	0.75	0.56	1.00	0.95	0.78	0.58	1.00	1.00	0.81	0.60	1.00	1.00	0.81	0.61
	ΔT	24	23	20	16	25	24	21	16	25	24	21	16	25	24	21	17	23	24	20	16	22	22	19	15
	kW	2.07	2.12	2.19	2.26	2.24	2.28	2.36	2.42	2.38	2.43	2.51	2.60	2.50	2.56	2.65	2.74	2.61	2.67	2.76	2.85	2.70	2.77	2.86	2.96
	Amps	9.9	10.1	10.4	10.7	10.6	10.8	11.1	11.5	11.4	11.6	11.9	12.3	12.0	12.3	12.7	13.1	12.7	13.0	13.4	13.8	13.4	13.7	14.1	14.6
	HI PR	220	237	250	261	247	266	281	293	281	302	319	333	320	344	364	379	360	387	409	427	398	428	452	471
	LO PR	109	116	126	135	115	122	134	142	120	127	139	148	126	134	146	155	132	140	153	163	136	145	158	168
	MBh	34.5	35.2	37.6	40.2	33.7	34.4	36.8	39.3	32.9	33.6	35.9	38.4	32.1	32.8	35.0	37.4	30.5	31.1	33.3	35.5	28.2	28.8	30.8	32.9
	S/T	0.88	0.83	0.67	0.50	0.92	0.86	0.70	0.52	0.94	0.88	0.72	0.54	0.97	0.91	0.74	0.55	1.00	0.94	0.77	0.57	1.00	0.95	0.77	0.58
	ΔT	25	24	21	17	26	25	21	17	26	25	21	17	26	25	22	17	25	25	21	17	24	23	20	16
kW	2.06	2.10	2.17	2.24	2.22	2.27	2.34	2.42	2.36	2.41	2.49	2.57	2.48	2.54	2.62	2.71	2.59	2.65	2.74	2.83	2.68	2.74	2.83	2.93	
Amps	9.9	10.0	10.3	10.6	10.5	10.7	11.0	11.4	11.3	11.5	11.8	12.2	12.0	12.2	12.6	13.0	12.6	12.9	13.3	13.7	13.3	13.6	14.0	14.4	
HI PR	218	235	248	258	245	263	278	290	278	299	316	330	317	341	360	375	356	384	405	422	394	424	447	467	
LO PR	108	115	125	133	114	121	132	141	118	126	137	146	124	132	144	154	130	139	151	161	135	143	157	167	
MBh	31.8	32.5	34.7	37.1	31.1	31.7	33.9	36.3	30.3	31.0	33.1	35.4	29.6	30.2	32.3	34.5	28.1	28.7	30.7	32.8	26.0	26.6	28.4	30.4	
S/T	0.85	0.80	0.65	0.49	0.88	0.83	0.67	0.50	0.91	0.85	0.69	0.52	0.93	0.88	0.71	0.53	0.97	0.91	0.74	0.55	0.98	0.92	0.75	0.56	
ΔT	26	25	22	17	26	25	22	17	26	25	22	17	26	25	22	18	26	25	21	17	24	23	20	16	
kW	2.01	2.05	2.11	2.18	2.16	2.21	2.28	2.36	2.30	2.35	2.43	2.51	2.42	2.48	2.56	2.64	2.52	2.58	2.67	2.76	2.61	2.67	2.76	2.86	
Amps	9.6	9.8	10.1	10.4	10.3	10.5	10.8	11.1	11.0	11.2	11.6	11.9	11.7	11.9	12.3	12.7	12.3	12.6	12.9	13.4	12.9	13.2	13.6	14.1	
HI PR	211	228	240	251	237	255	270	281	270	290	307	320	307	331	349	364	346	372	393	410	382	411	434	453	
LO PR	105	111	121	129	110	118	128	137	115	122	133	142	121	128	140	149	126	134	147	156	131	139	152	162	

85	MBh	36.1	36.8	38.6	41.1	35.3	36.0	37.7	40.2	34.4	35.1	36.8	39.2	33.6	34.2	35.9	38.3	31.9	32.5	34.1	36.4	29.6	30.1	31.6	33.7
	S/T	0.97	0.94	0.85	0.69	1.00	0.97	0.88	0.71	1.00	1.00	0.90	0.73	1.00	1.00	0.93	0.75	1.00	1.00	0.96	0.78	1.00	1.00	0.97	0.79
	ΔT	26	26	24	21	26	26	25	21	26	26	25	21	25	25	25	21	24	24	24	21	22	22	23	20
	kW	2.09	2.13	2.20	2.28	2.25	2.30	2.38	2.46	2.40	2.45	2.53	2.62	2.53	2.58	2.67	2.76	2.63	2.69	2.78	2.88	2.73	2.79	2.88	2.98
	Amps	10.0	10.2	10.5	10.8	10.7	10.9	11.2	11.6	11.5	11.7	12.0	12.4	12.1	12.4	12.8	13.2	12.8	13.1	13.5	13.9	13.5	13.8	14.2	14.7
	HI PR	222	239	253	264	249	268	284	296	284	305	322	336	323	348	367	383	364	391	413	431	402	432	456	476
	LO PR	110	117	128	136	116	124	135	144	121	128	140	149	127	135	147	157	133	141	154	164	137	146	160	170
	MBh	35.1	35.7	37.4	39.9	34.3	34.9	36.6	39.0	33.4	34.1	35.7	38.1	32.6	33.3	34.8	37.2	31.0	31.6	33.1	35.3	28.7	29.3	30.6	32.7
	S/T	0.93	0.89	0.81	0.65	0.96	0.93	0.84	0.68	0.98	0.95	0.86	0.70	1.00	0.98	0.89	0.72	1.00	1.00	0.92	0.75	1.00	1.00	0.93	0.75
	ΔT	27	27	25	22	27	27	26	22	28	27	26	22	27	27	26	22	26	26	25	22	24	24	24	21
kW	2.07	2.12	2.19	2.26	2.24	2.28	2.36	2.44	2.38	2.43	2.51	2.60	2.50	2.56	2.65	2.74	2.61	2.67	2.76	2.85	2.70	2.77	2.86	2.96	
Amps	9.9	10.1	10.4	10.7	10.6	10.8	11.1	11.5	11.4	11.6	11.9	12.3	12.0	12.3	12.7	13.1	12.7	13.0	13.4	13.8	13.4	13.7	14.1	14.6	
HI PR	220	237	250	261	247	266	281	293	281	302	319	333	320	344	364	379	360	387	409	427	398	428	452	471	
LO PR	109	116	126	135	115	122	134	142	120	127	139	148	126	134	146	155	132	140	153	163	136	145	158	168	
MBh	32.4	33.0	34.6	36.9	31.6	32.2	33.8	36.0	30.9	31.5	32.9	35.1	30.1	30.7	32.1	34.3	28.6	29.2	30.5	32.6	26.5	27.0	28.3	30.2	
S/T	0.89	0.86	0.78	0.63	0.93	0.89	0.81	0.65	0.95	0.92	0.83	0.67	0.98	0.95	0.85	0.69	1.00	0.98	0.89	0.72	1.00	0.99	0.89	0.72	
ΔT	28	27	26	22	28	27	26	22	28	28	26	23	28	28	26	23	27	27	26	22	25	26	24	21	
kW	2.02	2.07	2.13	2.20	2.18	2.23	2.30	2.38	2.32	2.37	2.45	2.53	2.44	2.50	2.58	2.67	2.55	2.60	2.69	2.78	2.64	2.69	2.79	2.88	
Amps	9.7	9.9	10.2	10.5	10.4	10.6	10.9	11.2	11.1	11.3	11.7	12.0	11.8	12.0	12.4	12.8	12.4	12.7	13.0	13.5	13.1	13.3	13.7	14.2	
HI PR	214	230	243	253	240	258	272	284	273	293	310	323	310	334	353	368	349	376	397	414	386	415	438	457	
LO PR	106	112	123	131	112	119	130	138	116	123	135	143	122	130	141	151	128	136	148	158	132	140	153	163	

IDB = Entering Indoor Dry Bulb Temperature
 High and low pressures are measured at the liquid and suction service valves.
 Shaded area reflects AHRI (TVA) conditions
 kW = Total system power
 Amps = outdoor unit amps (comp. + fan)

EXPANDED COOLING DATA — ASXC160481B* / CA*F4860*6** +TXV/MBVC2000** HIGH STAGE

IDB	AIRFLOW	OUTDOOR AMBIENT TEMPERATURE																							
		65°F				75°F				85°F				95°F				105°F				115°F			
		59	63	67	71	59	63	67	71	59	63	67	71	59	63	67	71	59	63	67	71	59	63	67	71
70	MBh	46.1	47.7	52.3	-	45.0	46.6	51.1	-	43.9	45.5	49.9	-	42.8	44.4	48.7	-	40.7	42.2	46.2	-	37.7	39.1	42.8	-
	S/T	0.74	0.62	0.43	-	0.77	0.64	0.45	-	0.79	0.66	0.46	-	0.82	0.68	0.47	-	0.85	0.71	0.49	-	0.85	0.71	0.49	-
	ΔT	17	15	11	-	18	15	12	-	18	15	12	-	18	15	12	-	18	15	12	-	16	14	11	-
	kW	3.03	3.10	3.19	-	3.27	3.34	3.45	-	3.48	3.55	3.67	-	3.66	3.74	3.87	-	3.82	3.90	4.03	-	3.95	4.04	4.18	-
	Amps	14.6	14.9	15.3	-	15.5	15.9	16.3	-	16.7	17.0	17.5	-	17.6	18.0	18.5	-	18.6	19.0	19.5	-	19.5	20.0	20.5	-
	HI PR	235	253	267	-	264	284	300	-	300	323	341	-	341	367	388	-	384	413	437	-	424	457	482	-
	LO PR	104	111	121	-	110	117	128	-	114	122	133	-	120	128	140	-	126	134	146	-	130	139	151	-
	MBh	44.7	46.3	50.8	-	43.7	45.3	49.6	-	42.6	44.2	48.4	-	41.6	43.1	47.2	-	39.5	41.0	44.9	-	36.6	37.9	41.6	-
	S/T	0.71	0.59	0.41	-	0.73	0.61	0.43	-	0.75	0.63	0.44	-	0.78	0.65	0.45	-	0.81	0.67	0.47	-	0.81	0.68	0.47	-
	ΔT	18	16	12	-	18	16	12	-	18	16	12	-	19	16	12	-	18	16	12	-	17	15	11	-
	kW	3.01	3.07	3.17	-	3.24	3.31	3.42	-	3.45	3.52	3.64	-	3.63	3.71	3.83	-	3.78	3.87	4.00	-	3.92	4.01	4.14	-
	Amps	14.5	14.8	15.1	-	15.4	15.7	16.2	-	16.5	16.9	17.3	-	17.5	17.8	18.4	-	18.4	18.8	19.4	-	19.4	19.8	20.4	-
HI PR	233	250	264	-	261	281	297	-	297	319	337	-	338	364	384	-	380	409	432	-	420	452	478	-	
LO PR	103	110	120	-	109	116	127	-	113	120	132	-	119	127	138	-	125	133	145	-	129	137	150	-	
MBh	41.3	42.8	46.9	-	40.3	41.8	45.8	-	39.4	40.8	44.7	-	38.4	39.8	43.6	-	36.5	37.8	41.4	-	33.8	35.0	38.4	-	
S/T	0.68	0.57	0.40	-	0.71	0.59	0.41	-	0.73	0.61	0.42	-	0.75	0.63	0.43	-	0.78	0.65	0.45	-	0.78	0.66	0.45	-	
ΔT	19	16	12	-	19	16	12	-	19	16	12	-	19	16	12	-	19	16	12	-	17	15	11	-	
kW	2.93	3.00	3.09	-	3.16	3.23	3.33	-	3.36	3.44	3.55	-	3.54	3.62	3.74	-	3.69	3.77	3.90	-	3.82	3.90	4.04	-	
Amps	14.2	14.4	14.8	-	15.1	15.4	15.8	-	16.1	16.5	16.9	-	17.1	17.4	17.9	-	18.0	18.4	18.9	-	18.9	19.3	19.9	-	
HI PR	226	243	256	-	253	272	288	-	288	310	327	-	328	353	373	-	369	397	419	-	408	439	463	-	
LO PR	100	106	116	-	106	112	123	-	110	117	128	-	115	123	134	-	121	129	140	-	125	133	145	-	

75	MBh	46.8	48.2	52.2	56.0	45.7	47.1	51.0	54.7	44.7	46.0	49.8	53.4	43.6	44.9	48.6	52.1	41.4	42.6	46.1	49.5	38.3	39.5	42.7	45.9
	S/T	0.84	0.76	0.57	0.37	0.88	0.78	0.59	0.38	0.90	0.80	0.61	0.39	0.93	0.83	0.63	0.40	0.96	0.86	0.65	0.42	0.97	0.87	0.66	0.42
	ΔT	20	19	15	11	20	19	15	11	20	19	15	11	21	19	16	11	20	19	15	11	19	17	14	10
	kW	3.06	3.12	3.22	3.33	3.29	3.37	3.48	3.59	3.51	3.58	3.70	3.83	3.69	3.77	3.90	4.03	3.85	3.94	4.07	4.21	3.99	4.08	4.21	4.36
	Amps	14.7	15.0	15.4	15.9	15.7	16.0	16.4	16.9	16.8	17.1	17.6	18.2	17.8	18.1	18.6	19.3	18.7	19.1	19.7	20.3	19.7	20.1	20.7	21.4
	HI PR	237	255	270	281	266	287	303	316	303	326	344	359	345	371	392	409	388	418	441	460	429	461	487	508
	LO PR	105	112	122	130	111	118	129	138	116	123	134	143	121	129	141	150	127	135	148	157	132	140	153	163
	MBh	45.5	46.8	50.7	54.4	44.4	45.7	49.5	53.1	43.4	44.6	48.3	51.9	42.3	43.6	47.1	50.6	40.2	41.4	44.8	48.1	37.2	38.3	41.5	44.5
	S/T	0.81	0.72	0.55	0.35	0.84	0.75	0.57	0.36	0.86	0.77	0.58	0.37	0.88	0.79	0.60	0.38	0.92	0.82	0.62	0.40	0.93	0.83	0.63	0.40
	ΔT	21	19	16	11	21	20	16	11	21	20	16	11	21	20	16	11	21	20	16	11	20	18	15	10
	kW	3.03	3.10	3.20	3.30	3.27	3.34	3.45	3.56	3.48	3.55	3.67	3.79	3.66	3.74	3.87	4.00	3.82	3.90	4.03	4.17	3.95	4.04	4.18	4.32
	Amps	14.6	14.9	15.3	15.7	15.5	15.9	16.3	16.8	16.7	17.0	17.5	18.0	17.6	18.0	18.5	19.1	18.6	19.0	19.5	20.2	19.5	20.0	20.5	21.2
HI PR	235	253	267	278	264	284	300	312	300	323	341	355	342	368	388	405	384	413	437	455	424	457	482	503	
LO PR	104	111	121	129	110	117	128	136	114	122	133	142	120	128	140	149	126	134	146	156	130	139	151	161	
MBh	42.0	43.2	46.8	50.2	41.0	42.2	45.7	49.0	40.0	41.2	44.6	47.9	39.0	40.2	43.5	46.7	37.1	38.2	41.3	44.4	34.4	35.4	38.3	41.1	
S/T	0.78	0.69	0.53	0.34	0.81	0.72	0.55	0.35	0.83	0.74	0.56	0.36	0.85	0.76	0.58	0.37	0.88	0.79	0.60	0.39	0.89	0.80	0.60	0.39	
ΔT	21	20	16	11	22	20	16	11	22	20	16	11	22	20	16	11	22	20	16	11	20	19	15	10	
kW	2.96	3.02	3.12	3.22	3.19	3.26	3.36	3.47	3.39	3.46	3.58	3.70	3.57	3.65	3.77	3.90	3.72	3.80	3.93	4.06	3.85	3.94	4.07	4.21	
Amps	14.3	14.5	14.9	15.4	15.2	15.5	15.9	16.4	16.3	16.6	17.1	17.6	17.2	17.6	18.1	18.6	18.1	18.5	19.1	19.7	19.1	19.5	20.0	20.7	
HI PR	228	245	259	270	256	275	291	303	291	313	331	345	331	356	376	393	373	401	423	442	412	443	468	488	
LO PR	101	108	117	125	107	114	124	132	111	118	129	137	117	124	135	144	122	130	142	151	126	134	147	156	

IDB = Entering Indoor Dry Bulb Temperature
 High and low pressures are measured at the liquid and suction service valves.
 Shaded area reflects ACCA (TVA) conditions
 kW = Total system power
 Amps = outdoor unit amps (comp.+fan)

EXPANDED COOLING DATA — ASXC160481B* / CA*F4860*6** +TXV/MBVC2000** HIGH STAGE (CONT.)

IDB	AIRFLOW	OUTDOOR AMBIENT TEMPERATURE												ENTERING INDOOR WET BULB TEMPERATURE												
		65°F				75°F				85°F				95°F				105°F				115°F				
		59	63	67	71	59	63	67	71	59	63	67	71	59	63	67	71	59	63	67	71	59	63	67	71	
80	1800	MBh	47.7	48.7	52.0	55.6	46.6	47.6	50.8	54.3	45.5	46.4	49.6	53.0	44.3	45.3	48.4	51.8	42.1	43.0	46.0	49.2	39.0	39.9	42.6	45.5
		S/T	0.93	0.87	0.71	0.53	0.96	0.90	0.73	0.55	1.00	0.92	0.75	0.56	1.00	0.95	0.78	0.58	1.00	1.00	0.81	0.60	1.00	1.00	0.81	0.61
	ΔT	23	22	19	15	23	22	19	15	23	22	19	15	23	22	19	15	22	22	19	15	20	20	18	14	
	kW	3.08	3.15	3.25	3.35	3.32	3.39	3.51	3.62	3.53	3.61	3.73	3.86	3.72	3.81	3.93	4.07	3.88	3.97	4.10	4.24	4.02	4.11	4.25	4.40	
	Amps	14.8	15.1	15.5	16.0	15.8	16.1	16.5	17.1	16.9	17.3	17.8	18.3	17.9	18.3	18.8	19.4	18.9	19.3	19.8	20.5	19.9	20.3	20.9	21.6	
	HI PR	240	258	272	284	269	289	306	319	306	329	348	363	348	375	396	413	392	422	445	465	433	466	492	513	
	LO PR	106	113	123	131	112	119	130	139	117	124	136	144	123	130	142	152	129	137	149	159	133	141	154	164	
	MBh	46.3	47.3	50.5	54.0	45.2	46.2	49.4	52.8	44.1	45.1	48.2	51.5	43.1	44.0	47.0	50.2	40.9	41.8	44.7	47.7	37.9	38.7	41.4	44.2	
	S/T	0.88	0.83	0.67	0.50	0.92	0.86	0.70	0.52	0.94	0.88	0.72	0.54	0.97	0.91	0.74	0.55	1.00	0.94	0.77	0.57	1.00	0.95	0.77	0.58	
	ΔT	24	23	20	16	24	23	20	16	24	23	20	16	24	23	20	16	24	23	20	16	22	21	18	15	
	kW	3.06	3.12	3.22	3.33	3.29	3.37	3.48	3.59	3.51	3.58	3.70	3.83	3.69	3.77	3.90	4.03	3.85	3.94	4.07	4.21	3.99	4.08	4.21	4.36	
	Amps	14.7	15.0	15.4	15.9	15.7	16.0	16.4	16.9	16.8	17.1	17.6	18.2	17.8	18.1	18.7	19.3	18.7	19.1	19.7	20.3	19.7	20.1	20.7	21.4	
HI PR	237	255	270	281	266	287	303	316	303	326	344	359	345	371	392	409	388	418	441	460	429	461	487	508		
LO PR	105	112	122	130	111	118	129	138	116	123	134	143	121	129	141	150	127	135	148	157	132	140	153	163		
MBh	42.7	43.6	46.6	49.9	41.7	42.6	45.6	48.7	40.7	41.6	44.5	47.5	39.7	40.6	43.4	46.4	37.8	38.6	41.2	44.1	35.0	35.7	38.2	40.8		
S/T	0.85	0.80	0.65	0.49	0.88	0.83	0.67	0.50	0.91	0.85	0.69	0.52	0.93	0.88	0.71	0.53	0.97	0.91	0.74	0.55	0.98	0.92	0.75	0.56		
ΔT	24	23	20	16	24	23	20	16	24	23	20	16	24	23	20	16	24	23	20	16	22	22	19	15		
kW	2.98	3.05	3.14	3.24	3.21	3.28	3.39	3.50	3.42	3.49	3.61	3.73	3.60	3.68	3.80	3.93	3.75	3.84	3.96	4.10	3.88	3.97	4.11	4.25		
Amps	14.4	14.6	15.0	15.5	15.3	15.6	16.0	16.5	16.4	16.7	17.2	17.7	17.3	17.7	18.2	18.8	18.3	18.7	19.2	19.8	19.2	19.6	20.2	20.9		
HI PR	230	248	262	273	258	278	294	306	294	316	334	348	335	360	380	397	376	405	428	446	416	448	473	493		
LO PR	102	109	119	126	108	115	125	133	112	119	130	139	118	125	137	146	123	131	143	153	128	136	148	158		
85	1800	MBh	48.5	49.4	51.8	55.2	47.4	48.3	50.6	54.0	46.2	47.1	49.4	52.7	45.1	46.0	48.2	51.4	42.9	43.7	45.8	48.8	39.7	40.5	42.4	45.2
		S/T	0.97	0.94	0.85	0.69	1.00	0.97	0.88	0.71	1.00	1.00	0.90	0.73	1.00	1.00	0.93	0.75	1.00	1.00	0.96	0.78	1.00	1.00	0.97	0.79
	ΔT	24	24	22	19	24	23	20	16	24	24	23	20	23	23	23	20	22	22	23	19	20	21	21	18	
	kW	3.11	3.17	3.27	3.38	3.35	3.42	3.53	3.65	3.56	3.64	3.76	3.89	3.75	3.84	3.97	4.10	3.92	4.00	4.14	4.28	4.05	4.15	4.29	4.44	
	Amps	14.9	15.2	15.6	16.1	15.9	16.2	16.7	17.2	17.0	17.4	17.9	18.5	18.0	18.4	18.9	19.6	19.0	19.4	20.0	20.7	20.0	20.4	21.0	21.8	
	HI PR	242	261	275	287	272	292	309	322	309	332	351	366	352	379	400	417	396	426	450	469	437	471	497	518	
	LO PR	107	114	125	133	113	121	132	140	118	125	137	146	124	132	144	153	130	138	151	161	134	143	156	166	
	MBh	47.1	48.0	50.3	53.6	46.0	46.9	49.1	52.4	44.9	45.8	47.9	51.1	43.8	44.7	46.8	49.9	41.6	42.4	44.4	47.4	38.5	39.3	41.2	43.9	
	S/T	0.93	0.89	0.81	0.65	0.96	0.93	0.84	0.68	0.98	0.95	0.86	0.70	1.00	0.98	0.89	0.72	1.00	1.00	0.92	0.75	1.00	1.00	0.93	0.75	
	ΔT	25	25	23	20	25	25	24	20	25	25	24	20	25	25	24	21	24	24	23	20	22	23	22	19	
	kW	3.08	3.15	3.25	3.35	3.32	3.39	3.51	3.62	3.53	3.61	3.73	3.86	3.72	3.81	3.93	4.07	3.88	3.97	4.10	4.24	4.02	4.11	4.25	4.40	
	Amps	14.8	15.1	15.5	16.0	15.8	16.1	16.5	17.1	16.9	17.3	17.8	18.3	17.9	18.3	18.8	19.4	18.9	19.3	19.8	20.5	19.9	20.3	20.9	21.6	
HI PR	240	258	272	284	269	289	306	319	306	329	348	363	348	375	396	413	392	422	445	465	433	466	492	513		
LO PR	106	113	123	131	112	119	130	139	117	124	136	144	123	130	142	152	129	137	149	159	133	141	154	164		
MBh	43.5	44.3	46.4	49.5	42.5	43.3	45.3	48.4	41.4	42.2	44.2	47.2	40.4	41.2	43.2	46.0	38.4	39.2	41.0	43.7	35.6	36.3	38.0	40.5		
S/T	0.89	0.86	0.78	0.63	0.93	0.89	0.81	0.65	0.95	0.92	0.83	0.67	0.98	0.95	0.85	0.69	1.00	0.98	0.89	0.72	1.00	0.99	0.89	0.72		
ΔT	25	25	24	21	26	25	24	21	26	25	24	21	26	26	24	21	25	25	24	21	23	24	22	19		
kW	3.01	3.07	3.17	3.27	3.24	3.31	3.42	3.53	3.45	3.52	3.64	3.76	3.63	3.71	3.83	3.96	3.78	3.87	4.00	4.13	3.92	4.01	4.14	4.28		
Amps	14.5	14.7	15.1	15.6	15.4	15.7	16.2	16.7	16.5	16.9	17.3	17.9	17.5	17.8	18.3	18.9	18.4	18.8	19.4	20.0	19.4	19.8	20.4	21.0		
HI PR	233	250	264	276	261	281	296	309	297	319	337	352	338	364	384	401	380	409	432	451	420	452	477	498		
LO PR	103	110	120	128	109	116	127	135	113	120	132	140	119	127	138	147	125	133	145	154	129	137	150	159		

IDB = Entering Indoor Dry Bulb Temperature
 High and low pressures are measured at the liquid and suction service valves.
 Shaded area reflects AHRI (TVA) conditions
 kW = Total system power
 Amps = outdoor unit amps (comp. +fan)

EXPANDED COOLING DATA — ASXC160601A* / CA*F4961*6A* + TXV / MBVC2000** LOW STAGE

IDB	AIRFLOW	OUTDOOR AMBIENT TEMPERATURE																							
		65°F				75°F				85°F				95°F				105°F				115°F			
		59	63	67	71	59	63	67	71	59	63	67	71	59	63	67	71	59	63	67	71	59	63	67	71
70	MBh	41.8	43.3	47.5	-	40.8	42.3	46.3	-	39.8	41.3	45.2	-	38.9	40.3	44.1	-	36.9	38.3	41.9	-	34.2	35.5	38.8	-
	S/T	0.75	0.62	0.43	-	0.78	0.65	0.45	-	0.80	0.66	0.46	-	0.82	0.69	0.47	-	0.85	0.71	0.49	-	0.86	0.72	0.50	-
	ΔT	18	16	12	-	18	16	12	-	18	16	12	-	19	16	12	-	18	16	12	-	17	15	11	-
	KW	2.61	2.67	2.76	-	2.83	2.89	2.99	-	3.02	3.09	3.19	-	3.19	3.26	3.37	-	3.33	3.41	3.52	-	3.45	3.53	3.66	-
	Amps	10.1	10.3	10.7	-	10.9	11.2	11.6	-	11.9	12.2	12.6	-	12.7	13.0	13.5	-	14.9	15.2	15.8	-	15.7	16.1	16.7	-
	HI PR	231	248	252	-	253	272	276	-	297	319	323	-	338	363	368	-	380	409	415	-	439	472	479	-
	Lo PR	120	124	136	-	124	128	140	-	128	132	144	-	132	136	148	-	134	139	151	-	138	142	155	-
	MBh	40.6	42.0	46.1	-	39.6	41.1	45.0	-	38.7	40.1	43.9	-	37.7	39.1	42.9	-	35.9	37.2	40.7	-	33.2	34.4	37.7	-
	S/T	0.71	0.60	0.41	-	0.74	0.62	0.43	-	0.76	0.63	0.44	-	0.78	0.65	0.45	-	0.81	0.68	0.47	-	0.82	0.68	0.47	-
	ΔT	19	16	12	-	19	17	13	-	19	17	13	-	19	17	13	-	19	17	13	-	18	15	12	-
	KW	2.59	2.65	2.74	-	2.80	2.87	2.97	-	2.99	3.06	3.17	-	3.16	3.23	3.34	-	3.30	3.38	3.49	-	3.42	3.50	3.62	-
	Amps	10.0	10.2	10.6	-	10.8	11.1	11.5	-	11.8	12.1	12.5	-	12.6	12.9	13.4	-	14.7	15.1	15.6	-	15.6	15.9	16.5	-
HI PR	228	246	249	-	251	270	274	-	294	316	320	-	335	360	365	-	376	405	410	-	435	468	474	-	
Lo PR	119	123	134	-	123	127	138	-	127	131	143	-	130	134	147	-	133	137	150	-	136	141	153	-	
MBh	37.4	38.8	42.5	-	36.6	37.9	41.5	-	35.7	37.0	40.5	-	34.8	36.1	39.6	-	33.1	34.3	37.6	-	30.7	31.8	34.8	-	
S/T	0.69	0.57	0.40	-	0.71	0.60	0.41	-	0.73	0.61	0.42	-	0.75	0.63	0.44	-	0.78	0.65	0.45	-	0.79	0.66	0.46	-	
ΔT	19	17	13	-	20	17	13	-	20	17	13	-	20	17	13	-	19	17	13	-	18	16	12	-	
KW	2.57	2.63	2.72	-	2.78	2.84	2.94	-	2.97	3.03	3.14	-	3.13	3.20	3.31	-	3.27	3.35	3.46	-	3.39	3.47	3.59	-	
Amps	9.9	10.1	10.5	-	10.7	11.0	11.4	-	11.7	12.0	12.4	-	12.5	12.8	13.2	-	14.6	15.0	15.5	-	15.4	15.8	16.3	-	
HI PR	226	243	247	-	248	267	271	-	291	313	317	-	331	356	361	-	373	401	406	-	431	463	469	-	
Lo PR	118	122	133	-	122	125	137	-	126	130	142	-	129	133	145	-	132	136	148	-	135	139	152	-	
75	MBh	42.5	43.8	47.4	50.8	41.5	42.7	46.3	49.6	40.5	41.7	45.2	48.5	39.5	40.7	44.1	47.3	37.6	38.7	41.9	44.9	34.8	35.8	38.8	41.6
	S/T	0.85	0.76	0.58	0.37	0.88	0.79	0.60	0.38	0.90	0.81	0.61	0.39	0.93	0.83	0.63	0.41	0.97	0.87	0.66	0.42	0.98	0.87	0.66	0.43
	ΔT	21	19	16	11	21	20	16	11	21	20	16	11	22	20	16	11	21	20	16	11	20	18	15	10
	KW	2.61	2.67	2.76	2.86	2.83	2.89	2.99	3.10	3.02	3.09	3.19	3.31	3.19	3.26	3.37	3.49	3.33	3.41	3.52	3.65	3.45	3.53	3.66	3.79
	Amps	10.1	10.3	10.7	11.1	10.9	11.2	11.6	12.0	11.9	12.2	12.6	13.1	12.7	13.0	13.5	14.0	14.9	15.2	15.8	16.4	15.7	16.1	16.7	17.3
	HI PR	231	248	252	257	253	272	276	282	297	319	323	331	338	363	368	377	380	409	415	424	439	472	479	490
	Lo PR	120	124	136	144	124	128	140	149	128	132	144	154	132	136	148	158	134	139	151	161	138	142	155	165
	MBh	41.3	42.5	46.0	49.3	40.3	41.5	44.9	48.2	39.3	40.5	43.8	47.1	38.4	39.5	42.8	45.9	36.5	37.5	40.6	43.6	33.8	34.8	37.6	40.4
	S/T	0.81	0.73	0.55	0.35	0.84	0.75	0.57	0.37	0.86	0.77	0.58	0.38	0.89	0.80	0.60	0.39	0.92	0.83	0.63	0.40	0.93	0.83	0.63	0.41
	ΔT	22	20	17	11	22	20	17	12	22	21	17	12	22	21	17	12	22	20	17	12	21	19	16	11
	KW	2.59	2.65	2.74	2.83	2.80	2.87	2.97	3.07	2.99	3.06	3.17	3.28	3.16	3.23	3.34	3.46	3.30	3.38	3.49	3.62	3.42	3.50	3.62	3.75
	Amps	10.0	10.2	10.6	11.0	10.8	11.1	11.5	11.9	11.8	12.1	12.5	13.0	12.6	12.9	13.4	13.9	14.7	15.1	15.6	16.2	15.6	15.9	16.5	17.1
HI PR	228	246	249	255	251	270	274	280	294	316	320	327	335	360	365	373	376	405	410	419	435	468	474	485	
Lo PR	119	123	134	143	123	127	138	147	127	131	143	152	130	134	147	156	133	137	150	159	136	141	153	163	
MBh	38.1	39.2	42.4	45.5	37.2	38.3	41.5	44.5	36.3	37.4	40.5	43.4	35.4	36.5	39.5	42.4	33.7	34.6	37.5	40.3	31.2	32.1	34.7	37.3	
S/T	0.78	0.70	0.53	0.34	0.81	0.72	0.55	0.35	0.83	0.74	0.56	0.36	0.86	0.77	0.58	0.37	0.89	0.80	0.60	0.39	0.90	0.80	0.61	0.39	
ΔT	22	21	17	12	23	21	17	12	23	21	17	12	23	21	17	12	23	21	17	12	21	19	16	11	
KW	2.57	2.63	2.72	2.81	2.78	2.84	2.94	3.04	2.97	3.03	3.14	3.25	3.13	3.20	3.31	3.43	3.27	3.35	3.46	3.58	3.39	3.47	3.59	3.72	
Amps	9.9	10.1	10.5	10.9	10.7	11.0	11.4	11.8	11.7	12.0	12.4	12.8	12.5	12.8	13.2	13.7	14.6	15.0	15.5	16.1	15.4	15.8	16.3	17.0	
HI PR	226	243	247	252	248	267	271	277	291	313	317	324	331	356	361	369	373	401	406	415	431	463	469	480	
Lo PR	118	122	133	142	122	125	137	146	126	130	142	151	129	133	145	155	132	136	148	158	135	139	152	162	

IDB = Entering Indoor Dry Bulb Temperature
 High and low pressures are measured at the liquid and suction service valves.
 Shaded area reflects ACCA (TVA) conditions
 Amps = outdoor unit amps (comp. + fan)
 kW = Total system power

EXPANDED COOLING DATA — ASXC160601A* / CA*F4961*6A* + TXV / MBVC2000** LOW STAGE (CONT.)

IDB	AIRFLOW	OUTDOOR AMBIENT TEMPERATURE												ENTERING INDOOR WET BULB TEMPERATURE											
		65°F				75°F				85°F				95°F				105°F				115°F			
		59	63	67	71	59	63	67	71	59	63	67	71	59	63	67	71	59	63	67	71	59	63	67	71
80	1575	43.3	44.2	47.2	50.5	42.2	43.2	46.1	49.3	41.2	42.1	45.0	48.1	40.2	41.1	43.9	47.0	38.2	39.1	41.7	44.6	35.4	36.2	38.7	41.3
	MBh	0.93	0.87	0.71	0.53	0.97	0.91	0.74	0.55	1.00	0.93	0.76	0.57	1.00	0.96	0.78	0.58	1.00	1.00	0.81	0.61	1.00	1.00	0.82	0.61
	S/T	24	23	20	16	24	23	20	16	23	23	20	16	23	23	20	16	22	23	20	16	21	21	18	15
	ΔT	2.61	2.67	2.76	2.86	2.83	2.89	2.99	3.10	3.02	3.09	3.19	3.31	3.19	3.26	3.37	3.49	3.33	3.41	3.52	3.65	3.45	3.53	3.66	3.79
	kW	10.1	10.3	10.7	11.1	10.9	11.2	11.6	12.0	11.9	12.2	12.6	13.1	12.7	13.0	13.5	14.0	14.9	15.2	15.8	16.4	15.7	16.1	16.7	17.3
	Amps	231	248	252	257	253	272	276	282	297	319	323	331	338	363	368	377	380	409	415	424	439	472	479	490
	HI PR	120	124	136	144	124	128	140	149	128	132	144	154	132	136	148	158	134	139	151	161	138	142	155	165
	Lo PR	42.0	42.9	45.8	49.0	41.0	41.9	44.8	47.9	40.0	40.9	43.7	46.7	39.1	39.9	42.6	45.6	37.1	37.9	40.5	43.3	34.4	35.1	37.5	40.1
	MBh	0.89	0.83	0.68	0.51	0.92	0.86	0.70	0.53	0.95	0.89	0.72	0.54	0.98	0.92	0.74	0.56	1.00	0.95	0.77	0.58	1.00	0.96	0.78	0.58
	S/T	25	24	20	16	25	24	21	17	25	24	21	17	25	24	21	17	25	24	21	16	23	22	19	15
ΔT	2.59	2.65	2.74	2.83	2.80	2.87	2.97	3.07	2.99	3.06	3.17	3.28	3.16	3.23	3.34	3.46	3.30	3.38	3.49	3.62	3.42	3.50	3.62	3.75	
kW	10.0	10.2	10.6	11.0	10.8	11.1	11.5	11.9	11.8	12.1	12.5	13.0	12.6	12.9	13.4	13.9	14.7	15.1	15.6	16.2	15.6	15.9	16.5	17.1	
Amps	228	246	249	255	251	270	274	280	294	316	320	327	335	360	365	373	376	405	410	419	435	468	474	485	
HI PR	119	123	134	143	123	127	138	147	127	131	143	152	130	134	147	156	133	137	150	159	136	141	153	163	
Lo PR	38.8	39.6	42.3	45.2	37.9	38.7	41.3	44.2	37.0	37.8	40.3	43.1	36.1	36.8	39.4	42.1	34.3	35.0	37.4	40.0	31.7	32.4	34.6	37.0	
MBh	0.86	0.80	0.65	0.49	0.89	0.83	0.68	0.51	0.91	0.85	0.70	0.52	0.94	0.88	0.72	0.54	0.98	0.92	0.75	0.56	0.98	0.92	0.75	0.56	
S/T	25	24	21	17	25	24	21	17	25	24	21	17	25	24	21	17	25	24	21	17	23	22	20	16	
ΔT	2.57	2.63	2.72	2.81	2.78	2.84	2.94	3.04	2.97	3.03	3.14	3.25	3.13	3.20	3.31	3.43	3.27	3.35	3.46	3.58	3.39	3.47	3.59	3.72	
kW	9.9	10.1	10.5	10.9	10.7	11.0	11.4	11.8	11.7	12.0	12.4	12.8	12.5	12.8	13.2	13.7	14.6	15.0	15.5	16.1	15.4	15.8	16.3	17.0	
Amps	226	243	247	252	248	267	271	277	291	313	317	324	331	356	361	369	373	401	406	415	431	463	469	480	
HI PR	118	122	133	142	122	125	137	146	126	130	142	151	129	133	145	155	132	136	148	158	135	139	152	162	
Lo PR	44.0	44.9	47.0	50.1	43.0	43.8	45.9	49.0	42.0	42.8	44.8	47.8	40.9	41.7	43.7	46.6	38.9	39.6	41.5	44.3	36.0	36.7	38.5	41.0	
MBh	0.98	0.94	0.85	0.69	1.00	0.98	0.88	0.72	1.00	1.00	0.90	0.73	1.00	1.00	0.93	0.76	1.00	1.00	0.97	0.79	1.00	1.00	0.98	0.79	
S/T	25	25	23	20	25	25	24	20	24	25	24	20	24	24	24	21	23	23	23	20	21	21	22	19	
ΔT	2.61	2.67	2.76	2.86	2.83	2.89	2.99	3.10	3.02	3.09	3.19	3.31	3.19	3.26	3.37	3.49	3.33	3.41	3.52	3.65	3.45	3.53	3.66	3.79	
kW	10.1	10.3	10.7	11.1	10.9	11.2	11.6	12.0	11.9	12.2	12.6	13.1	12.7	13.0	13.5	14.0	14.9	15.2	15.8	16.4	15.7	16.1	16.7	17.3	
Amps	231	248	252	257	253	272	276	282	297	319	323	331	338	363	368	377	380	409	415	424	439	472	479	490	
HI PR	120	124	136	144	124	128	140	149	128	132	144	154	132	136	148	158	134	139	151	161	138	142	155	165	
Lo PR	42.7	43.6	45.6	48.7	41.7	42.5	44.6	47.5	40.7	41.5	43.5	46.4	39.7	40.5	42.4	45.3	37.8	38.5	40.3	43.0	35.0	35.7	37.3	39.8	
MBh	0.93	0.90	0.81	0.66	0.97	0.93	0.84	0.68	0.99	0.96	0.86	0.70	1.00	0.99	0.89	0.72	1.00	1.00	0.92	0.75	1.00	1.00	0.93	0.76	
S/T	26	26	24	21	26	26	25	21	27	26	25	21	26	26	25	21	25	25	24	21	23	23	23	20	
ΔT	2.59	2.65	2.74	2.83	2.80	2.87	2.97	3.07	2.99	3.06	3.17	3.28	3.16	3.23	3.34	3.46	3.30	3.38	3.49	3.62	3.42	3.50	3.62	3.75	
kW	10.0	10.2	10.6	11.0	10.8	11.1	11.5	11.9	11.8	12.1	12.5	13.0	12.6	12.9	13.4	13.9	14.7	15.1	15.6	16.2	15.6	15.9	16.5	17.1	
Amps	228	246	249	255	251	270	274	280	294	316	320	327	335	360	365	373	376	405	410	419	435	468	474	485	
HI PR	119	123	134	143	123	127	138	147	127	131	143	152	130	134	147	156	133	137	150	159	136	141	153	163	
Lo PR	39.4	40.2	42.1	44.9	38.5	39.3	41.1	43.9	37.6	38.3	40.1	42.8	36.7	37.4	39.2	41.8	34.8	35.5	37.2	39.7	32.3	32.9	34.5	36.8	
MBh	0.90	0.87	0.78	0.64	0.93	0.90	0.81	0.66	0.96	0.92	0.83	0.68	0.99	0.95	0.86	0.70	1.00	0.99	0.89	0.72	1.00	1.00	0.90	0.73	
S/T	26.6	26	25	21	27	26	25	22	27	27	25	22	27	27	25	22	26	26	25	22	24	25	23	20	
ΔT	2.57	2.63	2.72	2.81	2.78	2.84	2.94	3.04	2.97	3.03	3.14	3.25	3.13	3.20	3.31	3.43	3.27	3.35	3.46	3.58	3.39	3.47	3.59	3.72	
kW	9.9	10.1	10.5	10.9	10.7	11.0	11.4	11.8	11.7	12.0	12.4	12.8	12.5	12.8	13.2	13.7	14.6	15.0	15.5	16.1	15.4	15.8	16.3	17.0	
Amps	226	243	247	252	248	267	271	277	291	313	317	324	331	356	361	369	373	401	406	415	431	463	469	480	
HI PR	118	122	133	142	122	125	137	146	126	130	142	151	129	133	145	155	132	136	148	158	135	139	152	162	
Lo PR	44.0	44.9	47.0	50.1	43.0	43.8	45.9	49.0	42.0	42.8	44.8	47.8	40.9	41.7	43.7	46.6	38.9	39.6	41.5	44.3	36.0	36.7	38.5	41.0	

IDB	AIRFLOW	OUTDOOR AMBIENT TEMPERATURE												ENTERING INDOOR WET BULB TEMPERATURE											
		65°F				75°F				85°F				95°F				105°F				115°F			
		59	63	67	71	59	63	67	71	59	63	67	71	59	63	67	71	59	63	67	71	59	63	67	71
85	1575	43.3	44.2	47.2	50.5	42.2	43.2	46.1	49.3	41.2	42.1	45.0	48.1	40.2	41.1	43.9	47.0	38.2	39.1	41.7	44.6	35.4	36.2	38.7	41.3
	MBh	0.93	0.87	0.71	0.53	0.97	0.91	0.74	0.55	1.00	0.93	0.76	0.57	1.00	0.96	0.78	0.58	1.00	1.00	0.81	0.61	1.00	1.00	0.82	0.61
	S/T	24	23	20	16	24	23	20	16	23	23	20	16	23	23	20	16	22	23	20	16	21	21	18	15
	ΔT	2.61	2.67	2.76	2.86	2.83	2.89	2.99	3.10	3.02	3.09	3.19	3.31	3.19	3.26	3.37	3.49	3.33	3.41	3.52	3.65	3.45	3.53	3.66	3.79
	kW	10.1	10.3	10.7	11.1	10.9	11.2	11.6	12.0	11.9	12.2	12.6	13.1	12.7	13.0	13.5	14.0	14.9	15.2	15.8	16.4	15.7	16.1	16.7	17.3
	Amps	231	248	252	257	253	272	276	282	297	319	323	331	338	363	368	377	380	409	415	424	439	472	479	490
	HI PR	120	124	136	144	124	128	140	149	128	132	144	154	132	136	148	158	134	139	151	161	138	142	155	165
	Lo PR	42.0	42.9	45.8	49.0	41.0	41.9	44.8	47.9	40.0	40.9	43.7	46.7	39.1	39.9	42.6	45.6	37.1	37.9	40.5	43.3	34.4	35.1	37.5	40.1
	MBh	0.89	0.83	0.68	0.51	0.92	0.86	0.70																	

EXPANDED COOLING DATA — ASXC160601A* / CA*F4961*6A* + TXV/ MBVC2000** HIGH STAGE

IDB	AIRFLOW	OUTDOOR AMBIENT TEMPERATURE																									
		65°F				75°F				85°F				95°F				105°F				115°F					
		59	63	67	71	59	63	67	71	59	63	67	71	59	63	67	71	59	63	67	71	59	63	67	71		
70	2025	MBh	55.9	57.9	63.4	-	54.6	56.5	62.0	-	53.3	55.2	60.5	-	52.0	53.9	59.0	-	49.4	51.2	56.1	-	45.7	47.4	51.9	-	
		S/T	0.77	0.64	0.44	-	0.79	0.66	0.46	-	0.81	0.68	0.47	-	0.84	0.70	0.49	-	0.87	0.73	0.50	-	0.88	0.73	0.51	-	
	ΔT	19	17	13	-	20	17	13	-	20	17	13	-	20	17	13	-	20	17	13	-	18	16	12	-		
	1800	kW	3.94	4.02	4.15	-	4.25	4.34	4.48	-	4.52	4.62	4.77	-	4.76	4.86	5.03	-	4.96	5.07	5.24	-	5.14	5.25	5.43	-	
		Amps	14.2	14.5	15.0	-	15.4	15.8	16.3	-	16.8	17.2	17.8	-	18.0	18.4	19.0	-	21.0	21.6	22.3	-	22.2	22.8	23.6	-	
	1575	HI PR	247	266	269	-	271	292	296	-	318	342	346	-	362	389	395	-	407	438	444	-	470	506	513	-	
		Lo PR	118	121	132	-	121	125	136	-	125	129	141	-	128	132	145	-	131	135	148	-	134	138	151	-	
	75	2025	MBh	54.2	56.2	61.6	-	53.0	54.9	60.1	-	51.7	53.6	58.7	-	50.4	52.3	57.3	-	47.9	49.7	54.4	-	44.4	46.0	50.4	-
			S/T	0.73	0.61	0.42	-	0.76	0.63	0.44	-	0.78	0.65	0.45	-	0.80	0.67	0.46	-	0.83	0.69	0.48	-	0.84	0.70	0.49	-
		ΔT	20	18	13	-	20	18	13	-	20	18	13	-	21	18	14	-	20	18	13	-	19	16	12	-	
		1800	kW	3.91	3.99	4.12	-	4.21	4.30	4.44	-	4.48	4.58	4.73	-	4.72	4.82	4.98	-	4.92	5.03	5.20	-	5.09	5.21	5.39	-
			Amps	14.0	14.4	14.9	-	15.2	15.6	16.1	-	16.6	17.0	17.6	-	17.8	18.2	18.9	-	20.8	21.4	22.1	-	22.0	22.6	23.4	-
1575		HI PR	245	263	267	-	269	289	293	-	314	338	343	-	358	385	391	-	403	433	439	-	466	501	508	-	
		Lo PR	116	120	131	-	120	124	135	-	124	128	139	-	127	131	143	-	130	134	146	-	133	137	150	-	
70		2025	MBh	50.1	51.9	56.8	-	48.9	50.7	55.5	-	47.7	49.5	54.2	-	46.6	48.3	52.9	-	44.2	45.8	50.2	-	41.0	42.5	46.5	-
			S/T	0.70	0.59	0.41	-	0.73	0.61	0.42	-	0.75	0.63	0.43	-	0.77	0.65	0.45	-	0.80	0.67	0.46	-	0.81	0.68	0.47	-
		ΔT	21	18	14	-	21	18	14	-	21	18	14	-	21	18	14	-	21	18	14	-	19	17	13	-	
		1800	kW	3.87	3.96	4.08	-	4.18	4.27	4.41	-	4.44	4.54	4.69	-	4.68	4.78	4.94	-	4.88	4.99	5.16	-	5.05	5.17	5.34	-
			Amps	13.9	14.3	14.7	-	15.1	15.5	16.0	-	16.4	16.9	17.4	-	17.6	18.1	18.7	-	20.6	21.1	21.9	-	21.8	22.3	23.1	-
	1575	HI PR	242	260	264	-	266	286	290	-	311	335	340	-	355	381	387	-	399	429	435	-	461	496	503	-	
		Lo PR	115	119	130	-	119	122	134	-	123	126	138	-	126	130	142	-	128	132	145	-	132	136	148	-	

IDB	AIRFLOW	OUTDOOR AMBIENT TEMPERATURE																									
		65°F				75°F				85°F				95°F				105°F				115°F					
		59	63	67	71	59	63	67	71	59	63	67	71	59	63	67	71	59	63	67	71	59	63	67	71		
75	2025	MBh	56.8	58.5	63.3	67.9	55.5	57.1	61.8	66.4	54.2	55.8	60.4	64.8	52.8	54.4	58.9	63.2	50.2	51.7	55.9	60.0	46.5	47.9	51.8	55.6	
		S/T	0.87	0.78	0.59	0.38	0.90	0.81	0.61	0.39	0.93	0.83	0.63	0.40	0.95	0.85	0.65	0.42	0.99	0.89	0.67	0.43	1.00	0.89	0.68	0.44	
	ΔT	22	21	17	12	23	21	17	12	23	21	17	12	23	21	17	12	23	21	17	12	21	19	16	11		
	1800	kW	3.94	4.02	4.15	4.29	4.25	4.34	4.48	4.63	4.52	4.62	4.77	4.93	4.76	4.86	5.03	5.20	4.96	5.07	5.24	5.42	5.14	5.25	5.43	5.62	
		Amps	14.2	14.5	15.0	15.6	15.4	15.8	16.3	16.9	16.8	17.2	17.8	18.5	18.0	18.4	19.0	19.8	21.0	21.6	22.3	23.2	22.2	22.8	23.6	24.5	
	1575	HI PR	247	266	269	275	271	292	296	302	318	342	346	354	362	389	395	403	407	438	444	454	470	506	513	524	
		Lo PR	118	121	132	141	121	125	136	145	125	129	141	150	128	132	145	154	131	135	148	157	134	138	151	161	
	70	2025	MBh	55.1	56.8	61.5	66.0	53.9	55.5	60.0	64.4	52.6	54.1	58.6	62.9	51.3	52.8	57.2	61.4	48.7	50.2	54.3	58.3	45.1	46.5	50.3	54.0
			S/T	0.83	0.74	0.56	0.36	0.86	0.77	0.58	0.37	0.88	0.79	0.60	0.38	0.91	0.81	0.62	0.40	0.95	0.85	0.64	0.41	0.95	0.85	0.65	0.42
		ΔT	23	22	18	12	24	22	18	12	24	22	18	12	24	22	18	12	24	22	18	12	22	20	17	11	
		1800	kW	3.91	3.99	4.12	4.25	4.21	4.30	4.44	4.59	4.48	4.58	4.73	4.89	4.72	4.82	4.98	5.15	4.92	5.03	5.20	5.38	5.09	5.21	5.39	5.57
			Amps	14.0	14.4	14.9	15.5	15.2	15.6	16.1	16.8	16.6	17.0	17.6	18.3	17.8	18.2	18.9	19.6	20.8	21.4	22.1	23.0	22.0	22.6	23.4	24.3
1575		HI PR	245	263	267	273	269	289	293	299	314	338	343	350	358	385	391	399	403	433	439	449	466	501	508	519	
		Lo PR	116	120	131	140	120	124	135	144	124	128	139	149	127	131	143	153	130	134	146	156	133	137	150	159	
75		2025	MBh	50.9	52.4	56.7	60.9	49.7	51.2	55.4	59.5	48.5	50.0	54.1	58.1	47.3	48.8	52.8	56.6	45.0	46.3	50.1	53.8	41.7	42.9	46.4	49.8
			S/T	0.80	0.72	0.54	0.35	0.83	0.74	0.56	0.36	0.85	0.76	0.58	0.37	0.88	0.79	0.59	0.38	0.91	0.82	0.62	0.40	0.92	0.82	0.62	0.40
		ΔT	24	22	18	12	24	22	18	13	24	22	18	13	24	22	18	13	24	22	18	12	22	21	17	12	
		1800	kW	3.87	3.96	4.08	4.22	4.18	4.27	4.41	4.55	4.44	4.54	4.69	4.85	4.68	4.78	4.94	5.11	4.88	4.99	5.16	5.33	5.05	5.17	5.34	5.52
			Amps	13.9	14.3	14.7	15.3	15.1	15.5	16.0	16.6	16.4	16.9	17.4	18.1	17.6	18.1	18.7	19.4	20.6	21.1	21.9	22.7	21.8	22.3	23.1	24.0
	1575	HI PR	242	260	264	270	266	286	290	296	311	335	340	347	355	381	387	395	399	429	435	445	461	496	503	514	
		Lo PR	115	119	130	138	119	122	134	142	123	126	138	147	126	130	142	151	128	132	145	154	132	136	148	158	

IDB = Entering Indoor Dry Bulb Temperature
 High and low pressures are measured at the liquid and suction service valves.
 Shaded area reflects ACCA (TVA) conditions
 Amps = outdoor unit amps (comp.+fan)
 kW = Total system power

EXPANDED COOLING DATA — ASXC160601A* / CA*F4961*6A* + TXV/ MBVC2000** HIGH STAGE (CONT.)

IDB	AIRFLOW	OUTDOOR AMBIENT TEMPERATURE												ENTERING INDOOR WET BULB TEMPERATURE											
		65°F				75°F				85°F				95°F				105°F				115°F			
		59	63	67	71	59	63	67	71	59	63	67	71	59	63	67	71	59	63	67	71	59	63	67	71
80	MBh	57.8	59.1	63.1	67.5	56.5	57.7	61.6	65.9	55.1	56.3	60.2	64.3	53.8	55.0	58.7	62.8	51.1	52.2	55.8	59.6	47.3	48.4	51.7	55.2
		S/T	0.95	0.90	0.73	0.54	1.00	0.93	0.76	0.56	1.00	0.95	0.77	0.58	1.00	1.00	0.80	0.60	1.00	1.00	0.83	0.62	1.00	1.00	0.84
	ΔT	25	24	21	17	26	24	21	17	25	24	21	17	24	25	21	17	23	24	21	17	21	22	20	16
		3.94	4.02	4.15	4.29	4.25	4.34	4.48	4.63	4.52	4.62	4.77	4.93	4.76	4.86	5.03	5.20	4.96	5.07	5.24	5.42	5.14	5.25	5.43	5.62
	Amps	14.2	14.5	15.0	15.6	15.4	15.8	16.3	16.9	16.8	17.2	17.8	18.5	18.0	18.4	19.0	19.8	21.0	21.6	22.3	23.2	22.2	22.8	23.6	24.5
		HI PR	247	266	269	275	271	292	296	302	318	342	346	354	362	389	395	403	407	438	444	454	470	506	513
	Lo PR	118	121	132	141	121	125	136	145	125	129	141	150	128	132	145	154	131	135	148	157	134	138	151	161
		56.1	57.4	61.3	65.5	54.8	56.0	59.9	64.0	53.5	54.7	58.4	62.5	52.2	53.4	57.0	60.9	49.6	50.7	54.2	57.9	45.9	46.9	50.2	53.6
	S/T	0.91	0.85	0.70	0.52	0.94	0.88	0.72	0.54	0.97	0.91	0.74	0.55	1.00	0.94	0.76	0.57	1.00	0.97	0.79	0.59	1.00	0.98	0.80	0.60
		ΔT	26	25	22	17	26	25	22	18	26	25	22	18	27	26	22	18	25	25	22	17	23	24	20
	kW	3.91	3.99	4.12	4.25	4.21	4.30	4.44	4.59	4.48	4.58	4.73	4.89	4.72	4.82	4.98	5.15	4.92	5.03	5.20	5.38	5.09	5.21	5.39	5.57
		Amps	14.0	14.4	14.9	15.5	15.2	15.6	16.1	16.8	16.6	17.0	17.6	18.3	17.8	18.2	18.9	19.6	20.8	21.4	22.1	23.0	22.0	22.6	23.4
HI PR	245	263	267	273	269	289	293	299	314	338	343	350	358	385	391	399	403	433	439	449	466	501	508	519	
	Lo PR	116	120	131	140	120	124	135	144	124	128	139	149	127	131	143	153	130	134	146	156	133	137	150	159
MBh	51.8	52.9	56.6	60.5	50.6	51.7	55.2	59.1	49.4	50.5	53.9	57.6	48.2	49.2	52.6	56.2	45.8	46.8	50.0	53.4	42.4	43.3	46.3	49.5	
	S/T	0.88	0.82	0.67	0.50	0.91	0.85	0.69	0.52	0.93	0.88	0.71	0.53	0.96	0.90	0.74	0.55	1.00	0.94	0.76	0.57	1.01	0.95	0.77	0.58
ΔT	27	25	22	18	27	26	22	18	27	26	22	18	27	26	23	18	27	26	22	18	25	24	21	17	
	3.87	3.96	4.08	4.22	4.18	4.27	4.41	4.55	4.44	4.54	4.69	4.85	4.68	4.78	4.94	5.11	4.88	4.99	5.16	5.33	5.05	5.17	5.34	5.52	
Amps	13.9	14.3	14.7	15.3	15.1	15.5	16.0	16.6	16.4	16.9	17.4	18.1	17.6	18.1	18.7	19.4	20.6	21.1	21.9	22.7	21.8	22.3	23.1	24.0	
	HI PR	242	260	264	270	266	286	290	296	311	335	340	347	355	381	387	395	399	429	435	445	461	496	503	514
Lo PR	115	119	130	138	119	122	134	142	123	126	138	147	126	130	142	151	128	132	145	154	132	136	148	158	

85	MBh	58.8	60.0	62.8	67.0	57.5	58.6	61.3	65.4	56.1	57.2	59.9	63.9	54.7	55.8	58.4	62.3	52.0	53.0	55.5	59.2	48.2	49.1	51.4	54.8
		S/T	1.00	0.97	0.87	0.71	1.00	1.00	0.90	0.73	1.00	1.00	0.93	0.75	1.00	1.00	0.96	0.78	1.00	1.00	0.99	0.81	1.00	1.00	1.00
	ΔT	27	26	25	22	26	26	25	22	25	26	25	22	25	25	25	22	24	24	25	22	22	22	23	20
		3.94	4.02	4.15	4.29	4.25	4.34	4.48	4.63	4.52	4.62	4.77	4.93	4.76	4.86	5.03	5.20	4.96	5.07	5.24	5.42	5.14	5.25	5.43	5.62
	Amps	14.2	14.5	15.0	15.6	15.4	15.8	16.3	16.9	16.8	17.2	17.8	18.5	18.0	18.4	19.0	19.8	21.0	21.6	22.3	23.2	22.2	22.8	23.6	24.5
		HI PR	247	266	269	275	271	292	296	302	318	342	346	354	362	389	395	403	407	438	444	454	470	506	513
	Lo PR	118	121	132	141	121	125	136	145	125	129	141	150	128	132	145	154	131	135	148	157	134	138	151	161
		57.1	58.2	61.0	65.0	55.8	56.9	59.6	63.5	54.5	55.5	58.1	62.0	53.1	54.2	56.7	60.5	50.5	51.4	53.9	57.5	46.7	47.7	49.9	53.2
	S/T	0.95	0.92	0.83	0.67	0.99	0.95	0.86	0.70	1.00	0.98	0.88	0.72	1.00	1.00	0.91	0.74	1.00	1.00	0.95	0.77	1.00	1.00	0.95	0.77
		ΔT	28	27	26	22	28	28	26	23	28	28	26	23	27	28	26	23	26	26	26	23	24	24	24
	kW	3.91	3.99	4.12	4.25	4.21	4.30	4.44	4.59	4.48	4.58	4.73	4.89	4.72	4.82	4.98	5.15	4.92	5.03	5.20	5.38	5.09	5.21	5.39	5.57
		Amps	14.0	14.4	14.9	15.5	15.2	15.6	16.1	16.8	16.6	17.0	17.6	18.3	17.8	18.2	18.9	19.6	20.8	21.4	22.1	23.0	22.0	22.6	23.4
HI PR	245	263	267	273	269	289	293	299	314	338	343	350	358	385	391	399	403	433	439	449	466	501	508	519	
	Lo PR	116	120	131	140	120	124	135	144	124	128	139	149	127	131	143	153	130	134	146	156	133	137	150	159
MBh	52.7	53.7	56.3	60.0	51.5	52.5	55.0	58.6	50.3	51.2	53.7	57.2	49.0	50.0	52.3	55.8	46.6	47.5	49.7	53.1	43.1	44.0	46.1	49.1	
	S/T	0.92	0.89	0.80	0.65	0.95	0.92	0.83	0.67	0.98	0.94	0.85	0.69	1.00	0.97	0.88	0.71	1.00	1.00	0.91	0.74	1.00	1.00	0.92	0.75
ΔT	28	28	26	23	29	28	27	23	29	28	27	23	29	28	27	23	27	28	26	23	25	26	25	21	
	3.87	3.96	4.08	4.22	4.18	4.27	4.41	4.55	4.44	4.54	4.69	4.85	4.68	4.78	4.94	5.11	4.88	4.99	5.16	5.33	5.05	5.17	5.34	5.52	
Amps	13.9	14.3	14.7	15.3	15.1	15.5	16.0	16.6	16.4	16.9	17.4	18.1	17.6	18.1	18.7	19.4	20.6	21.1	21.9	22.7	21.8	22.3	23.1	24.0	
	HI PR	242	260	264	270	266	286	290	296	311	335	340	347	355	381	387	395	399	429	435	445	461	496	503	514
Lo PR	115	119	130	138	119	122	134	142	123	126	138	147	126	130	142	151	128	132	145	154	132	136	148	158	

IDB = Entering Indoor Dry Bulb Temperature
 High and low pressures are measured at the liquid and suction service valves.
 Shaded area reflects AHRI (TVA) conditions
 Amps = outdoor unit amps (comp.+fan)
 kW = Total system power

EXPANDED COOLING DATA — ASXC160601B* / CA*F496*6**+TXV / MBVC2000*-1** LOW STAGE

IDB	AIRFLOW	OUTDOOR AMBIENT TEMPERATURE																									
		65°F				75°F				85°F				95°F				105°F				115°F					
		59	63	67	71	59	63	67	71	59	63	67	71	59	63	67	71	59	63	67	71	59	63	67	71		
70	1350	MBh	39.3	40.7	44.6	-	38.3	39.7	43.5	-	37.4	38.8	42.5	-	36.5	37.8	41.5	-	34.7	36.0	39.4	-	32.1	33.3	36.5	-	
		S/T	0.73	0.61	0.42	-	0.76	0.63	0.44	-	0.78	0.65	0.45	-	0.80	0.67	0.47	-	0.83	0.70	0.48	-	0.84	0.70	0.49	-	
	1217	ΔT	20	17	13	-	20	17	13	-	20	17	13	-	20	17	13	-	20	17	13	-	18	16	12	-	
		kW	2.43	2.49	2.57	-	2.63	2.69	2.78	-	2.81	2.87	2.97	-	2.96	3.03	3.14	-	3.09	3.17	3.28	-	3.21	3.28	3.40	-	
	1050	Amps	9.9	10.1	10.4	-	10.7	10.9	11.3	-	11.6	11.9	12.3	-	12.4	12.7	13.1	-	13.2	13.5	14.0	-	14.0	14.3	14.8	-	
		HI PR	214	231	244	-	241	259	273	-	274	294	311	-	312	335	354	-	351	377	398	-	387	417	440	-	
	75	1350	LO PR	107	114	124	-	113	120	132	-	118	125	137	-	124	132	144	-	130	138	150	-	134	143	156	-
			MBh	38.7	40.1	43.9	-	37.8	39.2	42.9	-	36.9	38.2	41.9	-	36.0	37.3	40.9	-	34.2	35.4	38.8	-	31.7	32.8	35.9	-
		1217	S/T	0.70	0.59	0.41	-	0.73	0.61	0.42	-	0.75	0.62	0.43	-	0.77	0.64	0.45	-	0.80	0.67	0.46	-	0.81	0.67	0.47	-
			ΔT	21	18	13	-	21	18	14	-	21	18	14	-	21	18	14	-	21	18	14	-	19	17	13	-
		1050	kW	2.42	2.47	2.56	-	2.62	2.68	2.77	-	2.79	2.85	2.95	-	2.94	3.01	3.12	-	3.07	3.15	3.26	-	3.19	3.26	3.38	-
			Amps	9.8	10.0	10.4	-	10.6	10.9	11.2	-	11.5	11.8	12.2	-	12.3	12.6	13.0	-	13.1	13.4	13.9	-	13.9	14.2	14.7	-
75		1350	HI PR	213	229	242	-	239	257	271	-	272	292	309	-	309	333	352	-	348	375	396	-	385	414	437	-
			LO PR	106	113	124	-	112	120	131	-	117	124	136	-	123	131	143	-	129	137	149	-	133	142	155	-
		1217	MBh	35.7	37.0	40.5	-	34.9	36.1	39.6	-	34.0	35.3	38.6	-	33.2	34.4	37.7	-	31.5	32.7	35.8	-	29.2	30.3	33.2	-
			S/T	0.68	0.57	0.39	-	0.70	0.59	0.41	-	0.72	0.60	0.42	-	0.74	0.62	0.43	-	0.77	0.64	0.45	-	0.78	0.65	0.45	-
		1050	ΔT	21	18	14	-	21	19	14	-	21	19	14	-	22	19	14	-	21	18	14	-	20	17	13	-
			kW	2.36	2.41	2.49	-	2.55	2.61	2.69	-	2.72	2.78	2.88	-	2.87	2.93	3.03	-	2.99	3.06	3.17	-	3.10	3.18	3.29	-
	75	1350	Amps	9.5	9.8	10.1	-	10.3	10.6	10.9	-	11.2	11.5	11.8	-	12.0	12.3	12.7	-	12.7	13.0	13.5	-	13.5	13.8	14.3	-
			HI PR	207	222	235	-	232	249	263	-	264	284	299	-	300	323	341	-	338	363	384	-	373	401	424	-
		1217	LO PR	103	110	120	-	109	116	127	-	113	121	132	-	119	127	138	-	125	133	145	-	129	137	150	-
			MBh	39.92	41.10	44.49	47.75	38.99	40.14	43.45	46.64	38.06	39.19	42.42	45.52	37.13	38.23	41.38	44.41	35.28	36.32	39.31	42.19	32.68	33.64	36.42	39.08
		1050	S/T	0.83	0.75	0.56	0.36	0.86	0.77	0.58	0.38	0.89	0.79	0.60	0.39	0.91	0.82	0.62	0.40	0.95	0.85	0.64	0.41	0.96	0.86	0.65	0.42
			ΔT	23	21	17	12	23	21	17	12	23	21	17	12	23	21	17	12	23	21	17	12	21	20	16	11
75		1350	kW	2.45	2.51	2.59	2.68	2.65	2.72	2.81	2.90	2.83	2.90	3.00	3.10	2.99	3.06	3.16	3.27	3.12	3.19	3.31	3.42	3.24	3.31	3.43	3.55
			Amps	10.0	10.2	10.5	10.9	10.8	11.0	11.4	11.8	11.7	12.0	12.4	12.8	12.5	12.8	13.2	13.7	13.3	13.6	14.1	14.6	14.1	14.4	14.9	15.5
		1217	HI PR	217	233	246	257	243	262	276	288	276	297	314	328	315	339	358	373	354	381	402	420	391	421	445	464
			LO PR	108	115	126	134	114	122	133	142	119	126	138	147	125	133	145	154	131	139	152	162	135	144	157	167
		1050	MBh	39.3	40.5	43.8	47.0	38.4	39.6	42.8	45.9	37.5	38.6	41.8	44.9	36.6	37.7	40.8	43.8	34.8	35.8	38.7	41.6	32.2	33.1	35.9	38.5
			S/T	0.80	0.71	0.54	0.35	0.83	0.74	0.56	0.36	0.85	0.76	0.57	0.37	0.88	0.78	0.59	0.38	0.91	0.81	0.62	0.40	0.92	0.82	0.62	0.40
	75	1350	ΔT	24	22	18	12	24	22	18	13	24	22	18	13	24	22	18	13	24	22	18	12	22	21	17	12
			kW	2.44	2.49	2.58	2.67	2.64	2.70	2.79	2.89	2.81	2.88	2.98	3.08	2.97	3.04	3.14	3.25	3.10	3.17	3.28	3.40	3.22	3.29	3.41	3.53
		1217	Amps	9.9	10.1	10.5	10.9	10.7	11.0	11.3	11.7	11.6	11.9	12.3	12.8	12.4	12.7	13.1	13.6	13.2	13.5	14.0	14.5	14.0	14.4	14.8	15.4
			HI PR	215	231	244	255	241	260	274	286	274	295	312	325	313	336	355	370	352	378	400	417	389	418	442	461
		1050	LO PR	108	114	125	133	114	121	132	141	118	126	137	146	124	132	144	153	130	138	151	161	134	143	156	166
			MBh	36.3	37.4	40.5	43.4	35.5	36.5	39.5	42.4	34.6	35.6	38.6	41.4	33.8	34.8	37.6	40.4	32.1	33.0	35.8	38.4	29.7	30.6	33.1	35.5
75		1350	S/T	0.77	0.69	0.52	0.34	0.80	0.71	0.54	0.35	0.82	0.73	0.55	0.36	0.84	0.76	0.57	0.37	0.88	0.78	0.59	0.38	0.88	0.79	0.60	0.38
			ΔT	24	23	18	13	25	23	19	13	25	23	19	13	25	23	19	13	25	23	19	13	23	21	17	12
		1217	kW	2.38	2.43	2.51	2.60	2.57	2.63	2.72	2.81	2.74	2.80	2.90	3.00	2.89	2.96	3.06	3.17	3.02	3.09	3.20	3.31	3.13	3.20	3.32	3.43
			Amps	9.6	9.9	10.2	10.6	10.4	10.7	11.0	11.4	11.3	11.6	12.0	12.4	12.1	12.4	12.8	13.3	12.9	13.2	13.6	14.1	13.6	14.0	14.4	15.0
		1050	HI PR	209	224	237	247	234	252	266	277	266	286	303	316	303	326	345	359	341	367	388	404	377	406	428	447
			LO PR	104	111	121	129	110	117	128	136	115	122	133	142	120	128	140	149	126	134	146	156	130	139	151	161

IDB = Entering Indoor Dry Bulb Temperature
 High and low pressures are measured at the liquid and suction service valves.
 Shaded area reflects ACCA (TVA) conditions
 Amps = outdoor unit amps (comp.+fan)
 kW = Total system power

EXPANDED COOLING DATA — ASXC160601B* / CA*F496*6**+TXV / MBVC2000*-1** LOW STAGE (CONT.)

IDB	AIRFLOW	OUTDOOR AMBIENT TEMPERATURE												ENTERING INDOOR WET BULB TEMPERATURE											
		65°F				75°F				85°F				95°F				105°F				115°F			
		59	63	67	71	59	63	67	71	59	63	67	71	59	63	67	71	59	63	67	71	59	63	67	71
80	MBh	40.63	41.51	44.35	47.41	39.68	40.55	43.32	46.31	38.74	39.58	42.29	45.21	37.79	38.62	41.26	44.11	35.90	36.69	39.20	41.90	33.26	33.98	36.31	38.81
	S/T	0.91	0.86	0.70	0.52	0.95	0.89	0.72	0.54	0.97	0.91	0.74	0.55	1.00	0.94	0.77	0.57	1.00	0.98	0.79	0.59	1.00	0.98	0.80	0.60
	ΔT	25	24	21	17	26	25	21	17	26	25	21	17	26	25	22	17	24	24	22	17	23	23	20	16
	kW	2.47	2.53	2.62	2.70	2.68	2.74	2.83	2.93	2.86	2.92	3.02	3.13	3.01	3.08	3.19	3.30	3.15	3.22	3.33	3.45	3.26	3.34	3.46	3.58
	Amps	10.1	10.3	10.6	11.0	10.9	11.1	11.5	11.9	11.8	12.1	12.5	13.0	12.6	12.9	13.4	13.9	13.4	13.8	14.2	14.8	14.2	14.6	15.1	15.6
	HI PR	219	235	249	259	245	264	279	291	279	300	317	331	318	342	361	377	358	385	406	424	395	425	449	468
	LO PR	109	116	127	135	116	123	134	143	120	128	139	149	126	134	147	156	132	141	154	164	137	145	159	169
	MBh	40.0	40.9	43.7	46.7	39.1	39.9	42.7	45.6	38.2	39.0	41.7	44.5	37.2	38.0	40.6	43.5	35.4	36.1	38.6	41.3	32.8	33.5	35.8	38.2
	S/T	0.88	0.82	0.67	0.50	0.91	0.85	0.69	0.52	0.93	0.87	0.71	0.53	0.96	0.90	0.73	0.55	1.00	0.93	0.76	0.57	1.00	0.94	0.77	0.57
	ΔT	26	25	22	18	27	26	22	18	27	26	22	18	27	26	23	18	27	26	22	18	25	24	21	17
	kW	2.46	2.52	2.60	2.69	2.66	2.72	2.81	2.91	2.84	2.90	3.00	3.11	3.00	3.07	3.17	3.28	3.13	3.20	3.31	3.43	3.24	3.32	3.44	3.56
	Amps	10.0	10.2	10.6	11.0	10.8	11.1	11.4	11.8	11.7	12.0	12.4	12.9	12.5	12.8	13.3	13.8	13.3	13.7	14.1	14.7	14.1	14.5	15.0	15.5
HI PR	217	234	247	257	244	262	277	289	277	298	315	329	316	340	359	374	355	382	404	421	392	422	446	465	
LO PR	109	116	126	134	115	122	133	142	119	127	139	148	125	133	146	155	131	140	152	162	136	144	158	168	
MBh	36.9	37.8	40.3	43.1	36.1	36.9	39.4	42.1	35.2	36.0	38.5	41.1	34.4	35.1	37.5	40.1	32.6	33.4	35.6	38.1	30.2	30.9	33.0	35.3	
S/T	0.84	0.79	0.64	0.48	0.87	0.82	0.67	0.50	0.90	0.84	0.68	0.51	0.93	0.87	0.71	0.53	0.96	0.90	0.73	0.55	0.97	0.91	0.74	0.55	
ΔT	27	26	23	18	28	26	23	18	28	27	23	18	28	27	23	19	27	26	23	18	26	25	21	17	
kW	2.40	2.45	2.53	2.62	2.59	2.65	2.74	2.84	2.77	2.83	2.93	3.03	2.92	2.99	3.09	3.20	3.05	3.12	3.23	3.34	3.16	3.23	3.35	3.46	
Amps	9.7	10.0	10.3	10.7	10.5	10.8	11.1	11.5	11.4	11.7	12.1	12.5	12.2	12.5	12.9	13.4	13.0	13.3	13.7	14.3	13.7	14.1	14.6	15.1	
HI PR	211	227	239	250	236	254	269	280	269	289	306	319	306	330	348	363	345	371	392	408	381	410	433	451	
LO PR	105	112	122	130	111	118	129	138	116	123	134	143	122	129	141	150	127	135	148	158	132	140	153	163	
85	MBh	41.34	42.14	44.13	47.08	40.38	41.16	43.11	45.99	39.41	40.18	42.08	44.89	38.45	39.20	41.05	43.80	36.53	37.24	39.00	41.61	33.84	34.49	36.13	38.54
	S/T	0.96	0.92	0.83	0.68	0.99	0.96	0.86	0.70	1.00	0.98	0.89	0.72	1.00	1.00	0.92	0.74	1.00	1.00	0.95	0.77	1.00	1.00	0.96	0.78
	ΔT	27	27	25	22	27	27	25	22	27	27	25	22	26	27	26	22	25	25	25	22	23	23	24	20
	kW	2.50	2.55	2.64	2.73	2.70	2.76	2.86	2.96	2.88	2.95	3.05	3.16	3.04	3.11	3.22	3.33	3.18	3.25	3.36	3.48	3.29	3.37	3.49	3.61
	Amps	10.1	10.4	10.7	11.1	11.0	11.2	11.6	12.0	11.9	12.2	12.6	13.1	12.7	13.0	13.5	14.0	13.6	13.9	14.4	14.9	14.4	14.7	15.2	15.8
	HI PR	221	238	251	262	248	267	282	294	282	303	320	334	321	346	365	381	361	389	411	428	399	430	454	473
	LO PR	110	118	128	137	117	124	136	144	121	129	141	150	127	136	148	158	134	142	155	165	138	147	160	171
	MBh	40.7	41.5	43.5	46.4	39.8	40.5	42.5	45.3	38.8	39.6	41.5	44.2	37.9	38.6	40.4	43.1	36.0	36.7	38.4	41.0	33.3	34.0	35.6	38.0
	S/T	0.92	0.89	0.80	0.65	0.95	0.92	0.83	0.67	0.98	0.94	0.85	0.69	1.00	0.97	0.88	0.71	1.00	1.00	0.91	0.74	1.00	1.00	0.92	0.74
	ΔT	28	28	26	23	29	28	27	23	29	28	27	23	29	28	27	23	27	28	26	23	25	26	25	21
	kW	2.48	2.54	2.62	2.71	2.68	2.75	2.84	2.94	2.86	2.93	3.03	3.14	3.02	3.09	3.20	3.31	3.16	3.23	3.34	3.46	3.27	3.35	3.47	3.59
	Amps	10.1	10.3	10.7	11.1	10.9	11.2	11.5	12.0	11.8	12.1	12.5	13.0	12.7	13.0	13.4	13.9	13.5	13.8	14.3	14.8	14.3	14.6	15.1	15.7
HI PR	219	236	249	260	246	265	280	292	280	301	318	332	319	343	362	378	359	386	408	425	396	427	450	470	
LO PR	110	117	127	136	116	123	135	143	120	128	140	149	127	135	147	157	133	141	154	164	137	146	159	170	
MBh	37.6	38.3	40.1	42.8	36.7	37.4	39.2	41.8	35.8	36.5	38.3	40.8	35.0	35.6	37.3	39.8	33.2	33.9	35.5	37.8	30.8	31.4	32.9	35.0	
S/T	0.88	0.85	0.77	0.63	0.92	0.88	0.80	0.65	0.94	0.91	0.82	0.66	0.97	0.94	0.85	0.69	1.00	0.97	0.88	0.71	1.00	0.98	0.88	0.72	
ΔT	29	29	27	23	29	29	27	24	30	29	27	24	30	29	28	24	29	29	27	24	27	27	25	22	
kW	2.42	2.47	2.56	2.64	2.62	2.67	2.77	2.86	2.79	2.85	2.95	3.05	2.94	3.01	3.12	3.22	3.07	3.15	3.25	3.37	3.19	3.26	3.38	3.49	
Amps	9.8	10.0	10.4	10.8	10.6	10.9	11.2	11.6	11.5	11.8	12.2	12.6	12.3	12.6	13.0	13.5	13.1	13.4	13.9	14.4	13.9	14.2	14.7	15.3	
HI PR	213	229	242	252	239	257	271	283	272	292	309	322	309	333	352	367	348	374	395	412	385	414	437	456	
LO PR	106	113	124	132	112	120	131	139	117	124	136	145	123	131	143	152	129	137	149	159	133	142	155	165	

IDB = Entering Indoor Dry Bulb Temperature
 High and low pressures are measured at the liquid and suction service valves.
 Shaded area reflects AHRI (TVA) conditions
 Amps = outdoor unit amps (comp.+fan)
 kW = Total system power

EXPANDED COOLING DATA — ASXC160601B* / CA*F496*6**+TXV / MBVC2000*-1** HIGH STAGE

IDB	AIRFLOW	OUTDOOR AMBIENT TEMPERATURE																							
		65°F				75°F				85°F				95°F				105°F				115°F			
		59	63	67	71	59	63	67	71	59	63	67	71	59	63	67	71	59	63	67	71	59	63	67	71
70	MBh	55.9	57.9	63.4	-	54.6	56.5	62.0	-	53.3	55.2	60.5	-	52.0	53.9	59.0	-	49.4	51.2	56.1	-	45.7	47.4	51.9	-
	S/T	0.74	0.62	0.43	-	0.77	0.64	0.45	-	0.79	0.66	0.46	-	0.82	0.68	0.47	-	0.85	0.71	0.49	-	0.85	0.71	0.49	-
	ΔT	19	16	12	-	19	17	13	-	19	17	13	-	19	17	13	-	19	16	12	-	18	15	12	-
	kW	3.57	3.65	3.77	-	3.86	3.95	4.09	-	4.12	4.22	4.36	-	4.35	4.45	4.61	-	4.55	4.65	4.82	-	4.71	4.83	4.99	-
	Amps	14.1	14.4	14.9	-	15.2	15.6	16.2	-	16.6	17.0	17.6	-	17.8	18.2	18.9	-	19.0	19.4	20.1	-	20.1	20.6	21.3	-
	HI PR	231	248	262	-	259	279	294	-	295	317	335	-	336	361	381	-	377	406	429	-	417	449	474	-
	LO PR	104	111	121	-	110	117	128	-	114	122	133	-	120	128	140	-	126	134	146	-	130	139	151	-
	MBh	54.2	56.2	61.6	-	53.0	54.9	60.1	-	51.7	53.6	58.7	-	50.4	52.3	57.3	-	47.9	49.7	54.4	-	44.4	46.0	50.4	-
	S/T	0.71	0.59	0.41	-	0.73	0.61	0.43	-	0.75	0.63	0.44	-	0.78	0.65	0.45	-	0.81	0.67	0.47	-	0.81	0.68	0.47	-
	ΔT	20	17	13	-	20	17	13	-	20	17	13	-	20	17	13	-	20	17	13	-	18	16	12	-
	kW	3.54	3.62	3.74	-	3.83	3.92	4.05	-	4.09	4.18	4.33	-	4.31	4.41	4.57	-	4.51	4.61	4.77	-	4.67	4.78	4.95	-
	Amps	13.9	14.3	14.8	-	15.1	15.5	16.0	-	16.5	16.9	17.4	-	17.6	18.1	18.7	-	18.8	19.2	19.9	-	19.9	20.4	21.1	-
HI PR	229	246	260	-	256	276	291	-	292	314	331	-	332	357	377	-	374	402	425	-	413	444	469	-	
LO PR	103	110	120	-	109	116	127	-	113	120	132	-	119	127	138	-	125	133	145	-	129	137	150	-	
MBh	50.1	51.9	56.8	-	48.9	50.7	55.5	-	47.7	49.5	54.2	-	46.6	48.3	52.9	-	44.2	45.8	50.2	-	41.0	42.5	46.5	-	
S/T	0.68	0.57	0.40	-	0.71	0.59	0.41	-	0.73	0.61	0.42	-	0.75	0.63	0.43	-	0.78	0.65	0.45	-	0.78	0.66	0.45	-	
ΔT	20	17	13	-	20	17	13	-	20	18	13	-	20	18	13	-	20	17	13	-	19	16	12	-	
kW	3.45	3.53	3.65	-	3.73	3.82	3.95	-	3.98	4.07	4.21	-	4.20	4.30	4.45	-	4.39	4.49	4.65	-	4.55	4.66	4.82	-	
Amps	13.6	13.9	14.4	-	14.7	15.0	15.6	-	16.0	16.4	16.9	-	17.1	17.5	18.1	-	18.2	18.7	19.3	-	19.4	19.8	20.5	-	
HI PR	222	239	252	-	249	268	283	-	283	304	321	-	322	347	366	-	363	390	412	-	401	431	455	-	
LO PR	100	106	116	-	106	112	123	-	110	117	128	-	115	123	134	-	121	129	140	-	125	133	145	-	

2025	MBh	56.80	58.48	63.30	67.94	55.48	57.12	61.83	66.36	54.16	55.76	60.36	64.78	52.84	54.40	58.89	63.20	50.20	51.68	55.94	60.04	46.50	47.87	51.82	55.62
	S/T	0.84	0.76	0.57	0.37	0.88	0.78	0.59	0.38	0.90	0.80	0.61	0.39	0.93	0.83	0.63	0.40	0.96	0.86	0.65	0.42	0.97	0.87	0.66	0.42
	ΔT	22	20	16	11	22	20	17	12	22	20	17	12	22	20	17	12	22	20	17	11	20	19	15	11
	kW	3.60	3.68	3.81	3.94	3.90	3.99	4.12	4.27	4.16	4.26	4.40	4.56	4.39	4.49	4.65	4.81	4.59	4.70	4.86	5.03	4.76	4.87	5.04	5.22
	Amps	14.2	14.6	15.0	15.6	15.4	15.8	16.3	16.9	16.8	17.2	17.8	18.5	18.0	18.4	19.0	19.8	19.1	19.6	20.3	21.1	20.3	20.8	21.5	22.4
	HI PR	233	251	265	276	262	282	297	310	298	320	338	353	339	365	385	402	381	410	433	452	421	453	479	499
	LO PR	105	112	122	130	111	118	129	138	116	123	134	143	121	129	141	150	127	135	148	157	132	140	153	163
	MBh	55.1	56.8	61.5	66.0	53.9	55.5	60.0	64.4	52.6	54.1	58.6	62.9	51.3	52.8	57.2	61.4	48.7	50.2	54.3	58.3	45.1	46.5	50.3	54.0
	S/T	0.81	0.72	0.55	0.35	0.84	0.75	0.57	0.36	0.86	0.77	0.58	0.37	0.88	0.79	0.60	0.38	0.92	0.82	0.62	0.40	0.93	0.83	0.63	0.40
	ΔT	23	21	17	12	23	21	17	12	23	21	17	12	23	21	17	12	23	21	17	12	21	20	16	11
	kW	3.57	3.65	3.78	3.90	3.87	3.95	4.09	4.23	4.12	4.22	4.36	4.52	4.35	4.45	4.61	4.77	4.55	4.65	4.82	4.99	4.71	4.83	5.00	5.17
	Amps	14.1	14.4	14.9	15.5	15.3	15.6	16.2	16.8	16.6	17.0	17.6	18.3	17.8	18.2	18.9	19.6	19.0	19.4	20.1	20.9	20.1	20.6	21.3	22.2
HI PR	231	248	262	274	259	279	294	307	295	317	335	349	336	361	381	398	378	406	429	447	417	449	474	494	
LO PR	104	111	121	129	110	117	128	136	114	122	133	142	120	128	140	149	126	134	146	156	130	139	151	161	
MBh	50.9	52.4	56.7	60.9	49.7	51.2	55.4	59.5	48.5	50.0	54.1	58.1	47.3	48.8	52.8	56.6	45.0	46.3	50.1	53.8	41.7	42.9	46.4	49.8	
S/T	0.78	0.69	0.53	0.34	0.81	0.72	0.55	0.35	0.83	0.74	0.56	0.36	0.85	0.76	0.58	0.37	0.88	0.79	0.60	0.39	0.89	0.80	0.60	0.39	
ΔT	23	21	17	12	23	22	18	12	23	22	18	12	24	22	18	12	24	21	18	12	22	20	16	11	
kW	3.48	3.56	3.68	3.80	3.77	3.85	3.98	4.12	4.02	4.11	4.25	4.40	4.24	4.34	4.49	4.64	4.43	4.53	4.69	4.85	4.59	4.70	4.86	5.03	
Amps	13.7	14.0	14.5	15.0	14.8	15.2	15.7	16.3	16.1	16.5	17.1	17.8	17.3	17.7	18.3	19.0	18.4	18.9	19.5	20.3	19.5	20.0	20.7	21.5	
HI PR	224	241	254	265	251	270	286	298	286	308	325	339	326	350	370	386	366	394	416	434	405	435	460	480	
LO PR	101	108	117	125	107	114	124	132	111	118	129	137	117	124	135	144	122	130	142	151	126	134	147	156	

IDB = Entering Indoor Dry Bulb Temperature
 High and low pressures are measured at the liquid and suction service valves.
 Shaded area reflects ACCA (TVA) conditions
 Amps = outdoor unit amps (comp.+fan)
 kW = Total system power

EXPANDED COOLING DATA — ASXC160601B* / CA*F496*6**+TXV / MBVC2000*-1** HIGH STAGE (CONT.)

IDB	AIRFLOW	OUTDOOR AMBIENT TEMPERATURE												ENTERING INDOOR WET BULB TEMPERATURE											
		65°F				75°F				85°F				95°F				105°F				115°F			
		59	63	67	71	59	63	67	71	59	63	67	71	59	63	67	71	59	63	67	71	59	63	67	71
80	MBh	57.81	59.07	63.11	67.47	56.47	57.70	61.65	65.90	55.12	56.33	60.18	64.33	53.78	54.95	58.71	62.76	51.09	52.20	55.77	59.62	47.32	48.36	51.66	55.23
	S/T	0.93	0.87	0.71	0.53	0.96	0.90	0.73	0.55	1.00	0.92	0.75	0.56	1.00	0.95	0.78	0.58	1.00	1.00	0.81	0.60	1.00	1.00	0.81	0.61
	ΔT	24	23	20	16	25	24	21	16	25	24	21	16	24	24	21	17	23	24	20	16	21	22	19	15
	kW	3.63	3.72	3.84	3.97	3.93	4.02	4.16	4.30	4.20	4.29	4.44	4.60	4.43	4.53	4.69	4.86	4.63	4.74	4.90	5.08	4.80	4.91	5.09	5.27
	Amps	14.3	14.7	15.2	15.8	15.5	15.9	16.5	17.1	16.9	17.3	17.9	18.6	18.1	18.6	19.2	20.0	19.3	19.8	20.5	21.3	20.5	21.0	21.7	22.6
	HI PR	236	253	268	279	264	284	300	313	301	323	342	356	342	368	389	406	385	414	438	457	426	458	484	504
	LO PR	106	113	123	131	112	119	130	139	117	124	136	144	123	130	142	152	129	137	149	159	133	141	154	164
	MBh	56.1	57.4	61.3	65.5	54.8	56.0	59.9	64.0	53.5	54.7	58.4	62.5	52.2	53.4	57.0	60.9	49.6	50.7	54.2	57.9	45.9	46.9	50.2	53.6
	S/T	0.88	0.83	0.67	0.50	0.92	0.86	0.70	0.52	0.94	0.88	0.72	0.54	0.97	0.91	0.74	0.55	1.00	0.94	0.77	0.57	1.00	0.95	0.77	0.58
	ΔT	25	24	21	17	26	25	21	17	26	25	21	17	26	25	22	17	25	24	21	17	23	23	20	16
	kW	3.60	3.68	3.81	3.94	3.90	3.99	4.12	4.27	4.16	4.26	4.40	4.56	4.39	4.49	4.65	4.81	4.59	4.70	4.86	5.03	4.76	4.87	5.04	5.22
	Amps	14.2	14.6	15.1	15.6	15.4	15.8	16.3	16.9	16.8	17.2	17.8	18.5	18.0	18.4	19.0	19.8	19.1	19.6	20.3	21.1	20.3	20.8	21.5	22.4
HI PR	233	251	265	276	262	282	297	310	298	320	338	353	339	365	385	402	381	410	433	452	421	453	479	499	
LO PR	105	112	122	130	111	118	129	138	116	123	134	143	121	129	141	150	127	135	148	157	132	140	153	163	
MBh	51.8	52.9	56.6	60.5	50.6	51.7	55.2	59.1	49.4	50.5	53.9	57.6	48.2	49.2	52.6	56.2	45.8	46.8	50.0	53.4	42.4	43.3	46.3	49.5	
S/T	0.85	0.80	0.65	0.49	0.88	0.83	0.67	0.50	0.91	0.85	0.69	0.52	0.93	0.88	0.71	0.53	0.97	0.91	0.74	0.55	0.98	0.92	0.75	0.56	
ΔT	26	25	21	17	26	25	22	17	26	25	22	17	26	25	22	18	26	25	22	17	24	23	20	16	
kW	3.51	3.59	3.71	3.84	3.80	3.88	4.02	4.16	4.05	4.15	4.29	4.44	4.28	4.38	4.53	4.69	4.47	4.57	4.73	4.90	4.63	4.74	4.91	5.08	
Amps	13.8	14.2	14.6	15.2	15.0	15.3	15.9	16.5	16.3	16.7	17.3	17.9	17.4	17.9	18.5	19.2	18.6	19.1	19.7	20.5	19.7	20.2	20.9	21.7	
HI PR	226	243	257	268	254	273	288	301	289	311	328	342	329	354	374	390	370	398	420	438	409	440	464	484	
LO PR	102	109	119	126	108	115	125	133	112	119	130	139	118	125	137	146	123	131	143	153	128	136	148	158	
2025	MBh	58.82	59.96	62.80	67.00	57.45	58.57	61.34	65.44	56.09	57.17	59.88	63.88	54.72	55.78	58.42	62.32	51.98	52.99	55.50	59.21	48.15	49.08	51.41	54.84
	S/T	0.97	0.94	0.85	0.69	1.00	0.97	0.88	0.71	1.00	1.00	0.90	0.73	1.00	1.00	0.93	0.75	1.00	1.00	0.96	0.78	1.00	1.00	0.97	0.79
	ΔT	26	26	24	21	26	26	24	21	25	26	24	21	25	25	25	21	24	24	24	21	22	22	23	20
	kW	3.66	3.75	3.87	4.01	3.97	4.06	4.20	4.34	4.23	4.33	4.48	4.64	4.47	4.57	4.73	4.90	4.67	4.78	4.95	5.12	4.84	4.96	5.13	5.31
	Amps	14.5	14.8	15.3	15.9	15.7	16.1	16.6	17.3	17.1	17.5	18.1	18.8	18.3	18.8	19.4	20.2	19.5	20.0	20.7	21.5	20.7	21.2	22.0	22.8
	HI PR	238	256	270	282	267	287	303	316	304	327	345	360	346	372	393	410	389	419	442	461	430	463	488	509
	LO PR	107	114	125	133	113	121	132	140	118	125	137	146	124	132	144	153	130	138	151	161	134	143	156	166
	MBh	57.1	58.2	61.0	65.0	55.8	56.9	59.6	63.5	54.5	55.5	58.1	62.0	53.1	54.2	56.7	60.5	50.5	51.4	53.9	57.5	46.7	47.7	49.9	53.2
	S/T	0.93	0.89	0.81	0.65	0.96	0.93	0.84	0.68	0.98	0.95	0.86	0.70	1.00	0.98	0.89	0.72	1.00	1.00	0.92	0.75	1.00	1.00	0.93	0.75
	ΔT	27	27	25	22	27	27	25	22	27	27	25	22	27	27	26	22	26	26	25	22	24	24	24	20
	kW	3.63	3.72	3.84	3.97	3.93	4.02	4.16	4.30	4.20	4.29	4.44	4.60	4.43	4.53	4.69	4.86	4.63	4.74	4.90	5.08	4.80	4.91	5.09	5.27
	Amps	14.3	14.7	15.2	15.8	15.5	15.9	16.5	17.1	16.9	17.3	17.9	18.6	18.1	18.6	19.2	20.0	19.3	19.8	20.5	21.3	20.5	21.0	21.7	22.6
HI PR	236	253	268	279	264	284	300	313	301	323	342	356	342	368	389	406	385	414	438	457	426	458	484	504	
LO PR	106	113	123	131	112	119	130	139	117	124	136	144	123	130	142	152	129	137	149	159	133	141	154	164	
MBh	52.7	53.7	56.3	60.0	51.5	52.5	55.0	58.6	50.3	51.2	53.7	57.2	49.0	50.0	52.3	55.8	46.6	47.5	49.7	53.1	43.1	44.0	46.1	49.1	
S/T	0.89	0.86	0.78	0.63	0.93	0.89	0.81	0.65	0.95	0.92	0.83	0.67	0.98	0.95	0.85	0.69	1.00	0.98	0.89	0.72	1.00	0.99	0.89	0.72	
ΔT	27	27	26	22	28	27	26	22	28	27	26	22	28	28	26	23	27	27	26	22	25	25	24	21	
kW	3.54	3.62	3.74	3.87	3.83	3.92	4.05	4.19	4.09	4.18	4.33	4.48	4.31	4.41	4.57	4.73	4.51	4.61	4.77	4.94	4.67	4.78	4.95	5.13	
Amps	13.9	14.3	14.8	15.3	15.1	15.5	16.0	16.6	16.4	16.9	17.4	18.1	17.6	18.1	18.7	19.4	18.8	19.2	19.9	20.7	19.9	20.4	21.1	21.9	
HI PR	228	246	260	271	256	276	291	304	292	314	331	346	332	357	377	394	374	402	425	443	413	444	469	489	
LO PR	103	110	120	128	109	116	127	135	113	120	132	140	119	127	138	147	125	133	145	154	129	137	150	159	

IDB = Entering Indoor Dry Bulb Temperature
 High and low pressures are measured at the liquid and suction service valves.
 Shaded area reflects AHRI (TVA) conditions
 Amps = outdoor unit amps (comp.+fan)
 kW = Total system power

AHRI PERFORMANCE DATA

OUTDOOR UNIT	INDOOR UNITS		COOLING CAPACITY (BTU/H)		SEER ¹	EER ²	AHRI #
	COIL/AIR HANDLER	FURNACE/BLOWER	TOTAL	SENSIBLE			
ASXC16 0241B*	AEPF183016C*+TXV		24,000	18,000	16.0	13.0	3654962
	AEPF313716A*+TXV		24,400	18,300	16.0	13.0	3654963
	AVPTC183014A*		24,000	18,000	16.0	13.0	4431349
	CA*F3636*6C*+TXV	A*VC950714CXA*	24,000	18,000	16.0	13.0	4202505
	CA*F3636*6C*+TXV	G*VC90704CXA*	24,000	18,000	16.0	13.0	3654974
	CA*F3636*6C*+TXV	G*V90704C**	24,000	18,000	16.0	13.0	3654973
	CA*F3636*6C*+TXV	A*VC950704CXA*	24,000	18,000	16.0	13.0	3654972
	CA*F3636*6C*+TXV	A*VC950453BXA*	24,000	18,000	16.0	13.0	3654971
	CA*F3636*6C*+TXV	A*VC90704CXA*	24,000	18,000	16.0	13.0	3654970
	CA*F3636*6C*+TXV	A*VC80704BXA*	24,000	18,000	16.0	13.0	3654969
	CA*F3636*6C*+TXV	A*V90704C**	24,000	18,000	16.0	13.0	3654968
	CA*F3636*6C*+TXV	A*V90453B**	24,000	18,000	16.0	13.0	3654967
	CA*F3636*6C*+TXV	A*V80704B**	24,000	18,000	16.0	13.0	3654966
	CA*F3636*6C*+TXV	MBVC1200** -1A*	24,000	18,000	16.0	13.0	3654965
	CA*F3636*6C*+TXV	MBE1200** -1B*	24,000	18,000	16.0	13.0	3654964
	CA*F3636*6D*+TXV	G*VC90704CXA*	24,000	18,000	16.0	13.0	4392732
	CA*F3636*6D*+TXV	A*VC950714CXA*	24,000	18,000	16.0	13.0	4392731
	CA*F3636*6D*+TXV	A*VC950704CXA*	24,000	18,000	16.0	13.0	4392730
	CA*F3636*6D*+TXV	A*VC950453BXA*	24,000	18,000	16.0	13.0	4392729
	CA*F3636*6D*+TXV	A*VC90704CXA*	24,000	18,000	16.0	13.0	4392728
	CA*F3636*6D*+TXV	A*VC80704BXA*	24,000	18,000	16.0	13.0	4392727
	CA*F3636*6D*+TXV	MBVC1200** -1A*	24,000	18,000	16.0	13.0	4392726
	CA*F3642*6C*+TXV	A*VC950714CXA*	24,000	18,000	16.0	13.0	4586538
	CA*F3642*6C*+TXV	G*VC950714CXA*	24,000	18,000	16.0	13.0	4202506
	CA*F3642*6C*+TXV	G*VC950905CXA*	24,000	18,000	16.0	13.0	4200629
	CA*F3642*6C*+TXV	A*VC950905CXA*	24,000	18,000	16.0	13.0	4200627
	CA*F3642*6C*+TXV	G*VC950915DXA*	24,000	18,000	16.0	13.0	4199963
	CA*F3642*6C*+TXV	A*VC950915DXA*	24,000	18,000	16.0	13.0	4199962
	CA*F3642*6C*+TXV	G*VC950704CXA*	24,000	18,000	16.0	13.0	3654982
	CA*F3642*6C*+TXV	G*VC950453BXA*	24,000	18,000	16.0	13.0	3654981
	CA*F3642*6C*+TXV	G*VC90905DXA*	24,000	18,000	16.0	13.0	3654980
	CA*F3642*6C*+TXV	G*V950704C**	24,000	18,000	16.0	13.0	3654979
	CA*F3642*6C*+TXV	G*V950453B**	24,000	18,000	16.0	13.0	3654978
	CA*F3642*6C*+TXV	G*V90905D**	24,000	18,000	16.0	13.0	3654977
	CA*F3642*6C*+TXV	A*VC80704BXA*	24,000	18,000	16.0	13.0	3654976
	CA*F3642*6C*+TXV	A*V80704B**	24,000	18,000	16.0	13.0	3654975
	CA*F3642*6D*+TXV	A*VC950714CXA*	24,000	18,000	16.0	13.0	4586539
	CA*F3642*6D*+TXV	A*VC950704CXA*	24,000	18,000	16.0	13.0	4546775
	CA*F3642*6D*+TXV	G*VC950714CXA*	24,000	18,000	16.0	13.0	4202517
	CA*F3642*6D*+TXV	G*VC950905CXA*	24,000	18,000	16.0	13.0	4200633
	CA*F3642*6D*+TXV	A*VC950905CXA*	24,000	18,000	16.0	13.0	4200631
	CA*F3642*6D*+TXV	G*VC950915DXA*	24,000	18,000	16.0	13.0	4199967
CA*F3642*6D*+TXV	A*VC950915DXA*	24,000	18,000	16.0	13.0	4199965	
CA*F3642*6D*+TXV	G*VC950704CXA*	24,000	18,000	16.0	13.0	3881344	
CA*F3642*6D*+TXV	G*VC950453BXA*	24,000	18,000	16.0	13.0	3881343	
CA*F3642*6D*+TXV	G*VC90905DXA*	24,000	18,000	16.0	13.0	3881342	
CA*F3642*6D*+TXV	G*V950704CXA*	24,000	18,000	16.0	13.0	3881341	
CA*F3642*6D*+TXV	G*V950453B**	24,000	18,000	16.0	13.0	3881340	
CA*F3642*6D*+TXV	G*V90905D**	24,000	18,000	16.0	13.0	3881339	

See Notes on Page 45.

AHRI PERFORMANCE DATA (CONT.)

OUTDOOR UNIT	INDOOR UNITS		COOLING CAPACITY (BTU/H)		SEER ¹	EER ²	AHRI #
	COIL/AIR HANDLER	FURNACE/BLOWER	TOTAL	SENSIBLE			
ASXC16 0241B* (cont.)	CA*F3642*6D*+TXV	A*VC80704BXA*	24,000	18,000	16.0	13.0	3881338
	CA*F3642*6D*+TXV	A*V80704B**	24,000	18,000	16.0	13.0	3881337
	CHPF3636B6C*+TXV	G*VC950714CXA*	24,000	18,000	16.0	12.5	4202508
	CHPF3636B6C*+TXV	A*VC950714CXA*	24,000	18,000	16.0	12.5	4202507
	CHPF3636B6C*+TXV	G*VC950704CXA*	24,000	18,000	16.0	12.5	3654995
	CHPF3636B6C*+TXV	G*VC950453BXA*	24,000	18,000	16.0	13.0	3654994
	CHPF3636B6C*+TXV	G*V950704C**	24,000	18,000	16.0	12.5	3654993
	CHPF3636B6C*+TXV	G*V950453B**	24,000	18,000	16.0	13.0	3654992
	CHPF3636B6C*+TXV	A*VC950704CXA*	24,000	18,000	16.0	12.5	3654991
	CHPF3636B6C*+TXV	A*VC950453BXA*	24,000	18,000	16.0	13.0	3654990
	CHPF3636B6C*+TXV	A*VC90704CXA*	24,000	18,000	16.0	12.5	3654989
	CHPF3636B6C*+TXV	A*VC80704BXA*	24,000	18,000	16.0	13.0	3654988
	CHPF3636B6C*+TXV	A*V90704C**	24,000	18,000	16.0	12.5	3654987
	CHPF3636B6C*+TXV	A*V90453B**	24,000	18,000	16.0	13.0	3654986
	CHPF3636B6C*+TXV	A*V80704B**	24,000	18,000	16.0	13.0	3654985
	CHPF3636B6C*+TXV	MBVC1200** -1A*	24,000	18,000	16.0	13.0	3654984
	CHPF3636B6C*+TXV	MBE1200** -1B*	24,000	18,000	16.0	13.0	3654983
	CHPF3642C6C*+TXV	G*VC950714CXA*	24,000	18,000	16.0	13.0	4202510
	CHPF3642C6C*+TXV	A*VC950714CXA*	24,000	18,000	16.0	13.0	4202509
	CHPF3642C6C*+TXV	G*VC950704CXA*	24,000	18,000	16.0	13.0	3655004
	CHPF3642C6C*+TXV	G*VC950453BXA*	24,000	18,000	16.0	13.0	3655003
	CHPF3642C6C*+TXV	G*V950704C**	24,000	18,000	16.0	13.0	3655002
	CHPF3642C6C*+TXV	G*V950453B**	24,000	18,000	16.0	13.0	3655001
	CHPF3642C6C*+TXV	A*VC950704CXA*	24,000	18,000	16.0	13.0	3655000
	CHPF3642C6C*+TXV	A*VC950453BXA*	24,000	18,000	16.0	13.0	3654999
	CHPF3642C6C*+TXV	A*VC90704CXA*	24,000	18,000	16.0	13.0	3654998
	CHPF3642C6C*+TXV	A*V90704C**	24,000	18,000	16.0	13.0	3654997
	CHPF3642C6C*+TXV	A*V90453B**	24,000	18,000	16.0	13.0	3654996
	CHPF3743C6B*+TXV	G*VC950714CXA*	24,000	18,000	16.0	12.5	4202512
	CHPF3743C6B*+TXV	A*VC950714CXA*	24,000	18,000	16.0	12.5	4202511
	CHPF3743C6B*+TXV	G*VC950704CXA*	24,000	18,000	16.0	12.5	3655013
	CHPF3743C6B*+TXV	G*VC950453BXA*	24,000	18,000	16.0	12.5	3655012
	CHPF3743C6B*+TXV	G*V950704C**	24,000	18,000	16.0	12.5	3655011
	CHPF3743C6B*+TXV	G*V950453B**	24,000	18,000	16.0	12.5	3655010
	CHPF3743C6B*+TXV	A*VC950704CXA*	24,000	18,000	16.0	12.5	3655009
	CHPF3743C6B*+TXV	A*VC950453BXA*	24,000	18,000	16.0	12.5	3655008
	CHPF3743C6B*+TXV	A*VC90704CXA*	24,000	18,000	16.0	12.5	3655007
	CHPF3743C6B*+TXV	A*V90704C**	24,000	18,000	16.0	12.5	3655006
	CHPF3743C6B*+TXV	A*V90453B**	24,000	18,000	16.0	12.5	3655005
	CHTF3636B6A*+TXV	MBVC1200** -1A*	24,000	18,000	15.5	12.5	3655015
	CHTF3636B6A*+TXV	MBE1200** -1B*	24,000	18,000	15.5	12.5	3655014
	CSCF3036N6B*+TXV	G*VC950714CXA*	24,000	18,000	16.0	13.0	4202514
	CSCF3036N6B*+TXV	A*VC950714CXA*	24,000	18,000	16.0	13.0	4202513
	CSCF3036N6B*+TXV	G*VC950905CXA*	24,000	18,000	16.0	13.0	4200637
	CSCF3036N6B*+TXV	A*VC950905CXA*	24,000	18,000	16.0	13.0	4200635
	CSCF3036N6B*+TXV	G*VC950915DXA*	24,000	18,000	16.0	13.0	4199971
	CSCF3036N6B*+TXV	A*VC950915DXA*	24,000	18,000	16.0	13.0	4199969
	CSCF3036N6B*+TXV	G*VC950704CXA*	24,000	18,000	16.0	13.0	3655030
CSCF3036N6B*+TXV	G*VC950453BXA*	24,000	18,000	15.5	12.5	3655029	

See Notes on Page 45.

AHRI PERFORMANCE DATA (CONT.)

OUTDOOR UNIT	INDOOR UNITS		COOLING CAPACITY (BTU/H)		SEER ¹	EER ²	AHRI #
	COIL/AIR HANDLER	FURNACE/BLOWER	TOTAL	SENSIBLE			
ASXC16 0241B* (cont.)	CSCF3036N6B*+TXV	G*VC90905DXA*	24,000	18,000	16.0	13.0	3655028
	CSCF3036N6B*+TXV	G*VC90704CXA*	24,000	18,000	16.0	13.0	3655027
	CSCF3036N6B*+TXV	G*V950704C**	24,000	18,000	16.0	13.0	3655026
	CSCF3036N6B*+TXV	G*V950453B**	24,000	18,000	15.5	12.5	3655025
	CSCF3036N6B*+TXV	G*V90905D**	24,000	18,000	16.0	13.0	3655024
	CSCF3036N6B*+TXV	G*V90704C**	24,000	18,000	16.0	13.0	3655023
	CSCF3036N6B*+TXV	A*VC950704CXA*	24,000	18,000	16.0	13.0	3655022
	CSCF3036N6B*+TXV	A*VC950453BXA*	24,000	18,000	15.5	12.5	3655021
	CSCF3036N6B*+TXV	A*VC90704CXA*	24,000	18,000	16.0	13.0	3655020
	CSCF3036N6B*+TXV	A*VC80704BXA*	24,000	18,000	15.5	12.5	3655019
	CSCF3036N6B*+TXV	A*V90704C**	24,000	18,000	16.0	13.0	3655018
	CSCF3036N6B*+TXV	A*V90453B**	24,000	18,000	15.5	12.5	3655017
	CSCF3036N6B*+TXV	A*V80704B**	24,000	18,000	15.5	12.5	3655016
	CSCF3642N6C*+TXV	G*VC950714CXA*	24,000	18,000	16.0	13.0	4202516
	CSCF3642N6C*+TXV	A*VC950714CXA*	24,000	18,000	16.0	13.0	4202515
	CSCF3642N6C*+TXV	G*VC950905CXA*	24,000	18,000	16.0	13.0	4200640
	CSCF3642N6C*+TXV	A*VC950905CXA*	24,000	18,000	16.0	13.0	4200638
	CSCF3642N6C*+TXV	G*VC950915DXA*	24,000	18,000	16.0	13.0	4199973
	CSCF3642N6C*+TXV	A*VC950915DXA*	24,000	18,000	16.0	13.0	4199972
	CSCF3642N6C*+TXV	G*VC950704CXA*	24,000	18,000	16.0	13.0	3655045
	CSCF3642N6C*+TXV	G*VC950453BXA*	24,000	18,000	16.0	13.0	3655044
	CSCF3642N6C*+TXV	G*VC90905DXA*	24,000	18,000	16.0	13.0	3655043
	CSCF3642N6C*+TXV	G*VC90704CXA*	24,000	18,000	16.0	13.0	3655042
	CSCF3642N6C*+TXV	G*V950704C**	24,000	18,000	16.0	13.0	3655041
	CSCF3642N6C*+TXV	G*V950453B**	24,000	18,000	16.0	13.0	3655040
	CSCF3642N6C*+TXV	G*V90905D**	24,000	18,000	16.0	13.0	3655039
	CSCF3642N6C*+TXV	G*V90704C**	24,000	18,000	16.0	13.0	3655038
	CSCF3642N6C*+TXV	A*VC950704CXA*	24,000	18,000	16.0	13.0	3655037
	CSCF3642N6C*+TXV	A*VC950453BXA*	24,000	18,000	16.0	13.0	3655036
	CSCF3642N6C*+TXV	A*VC90704CXA*	24,000	18,000	16.0	13.0	3655035
	CSCF3642N6C*+TXV	A*VC80704BXA*	24,000	18,000	16.0	13.0	3655034
	CSCF3642N6C*+TXV	A*V90704C**	24,000	18,000	16.0	13.0	3655033
CSCF3642N6C*+TXV	A*V90453B**	24,000	18,000	16.0	13.0	3655032	
CSCF3642N6C*+TXV	A*V80704B**	24,000	18,000	16.0	13.0	3655031	
ASXC16 0361B*	AEPF313716A*+TXV		35,000	24,900	16.0	12.8	3655046
	AEPF426016C*+TXV		36,000	25,600	16.0	12.8	3655047
	AVPTC313714A*		35,000	24,900	16.0	12.8	4431350
	AVPTC426014A*		36,000	25,600	16.0	12.8	4431351
	CA*F3642*6C*+TXV	MBE1600**-1B*	35,000	24,900	16.0	12.5	3655048
	CA*F3642*6C*+TXV	MBVC1600**-1A*	35,000	24,900	16.0	12.5	3655049
	CA*F3642*6C*+TXV	G*VC950714CXA*	34,600	24,600	15.5	12.0	4202519
	CA*F3642*6C*+TXV	A*VC950714CXA*	34,600	24,600	15.5	12.0	4202518
	CA*F3642*6C*+TXV	G*VC950905CXA*	34,600	24,600	15.5	12.0	4200642
	CA*F3642*6C*+TXV	A*VC950905CXA*	34,600	24,600	15.5	12.0	4200641
	CA*F3642*6C*+TXV	G*VC950915DXA*	34,600	24,600	15.5	12.0	4199976
	CA*F3642*6C*+TXV	A*VC950915DXA*	34,600	24,600	15.5	12.0	4199974
	CA*F3642*6C*+TXV	G*VC951155DXA*	34,600	24,600	16.0	12.3	3655072
	CA*F3642*6C*+TXV	G*VC950905DXA*	34,600	24,600	16.0	12.3	3655071
	CA*F3642*6C*+TXV	G*VC950704CXA*	34,600	24,600	15.5	12.0	3655070

See Notes on Page 45.

AHRI PERFORMANCE DATA (CONT.)

OUTDOOR UNIT	INDOOR UNITS		COOLING CAPACITY (BTU/H)		SEER ¹	EER ²	AHRI #
	COIL/AIR HANDLER	FURNACE/BLOWER	TOTAL	SENSIBLE			
ASXC16 0361B* (cont.)	CA*F3642*6C*+TXV	G*VC950453BXA*	34,000	24,100	16.0	12.2	3655069
	CA*F3642*6C*+TXV	G*V951155D**	34,600	24,600	16.0	12.3	3655068
	CA*F3642*6C*+TXV	G*V950905D**	34,600	24,600	16.0	12.3	3655067
	CA*F3642*6C*+TXV	G*V950704C**	34,600	24,600	15.5	12.0	3655066
	CA*F3642*6C*+TXV	G*V950453B**	34,000	24,100	16.0	12.2	3655065
	CA*F3642*6C*+TXV	A*VC951155DXA*	34,600	24,600	16.0	12.3	3655064
	CA*F3642*6C*+TXV	A*VC950905DXA*	34,600	24,600	16.0	12.3	3655063
	CA*F3642*6C*+TXV	A*VC950704CXA*	34,600	24,600	15.5	12.0	3655062
	CA*F3642*6C*+TXV	A*VC950453BXA*	34,000	24,100	15.5	12.0	3655061
	CA*F3642*6C*+TXV	A*VC90905DXA*	34,600	24,600	16.0	12.3	3655060
	CA*F3642*6C*+TXV	A*VC90704CXA*	34,600	24,600	15.5	12.0	3655059
	CA*F3642*6C*+TXV	A*VC80905CXA*	35,000	24,900	15.5	12.0	3655058
	CA*F3642*6C*+TXV	A*VC80704BXA*	34,000	24,100	16.0	12.5	3655057
	CA*F3642*6C*+TXV	A*V91155D**	34,600	24,600	16.0	12.3	3655056
	CA*F3642*6C*+TXV	A*V90905D**	34,600	24,600	16.0	12.3	3655055
	CA*F3642*6C*+TXV	A*V90704C**	34,600	24,600	15.5	12.0	3655054
	CA*F3642*6C*+TXV	A*V90453B**	34,000	24,100	15.5	12.0	3655053
	CA*F3642*6C*+TXV	A*V81155C**	34,600	24,600	15.5	12.0	3655052
	CA*F3642*6C*+TXV	A*V80905C**	35,000	24,900	15.5	12.0	3655051
	CA*F3642*6C*+TXV	A*V80704B**	34,000	24,100	16.0	12.5	3655050
	CA*F3642*6D*+TXV	MBE1600**-1B*	35,000	24,900	16.0	12.5	3881335
	CA*F3642*6D*+TXV	MBVC1600**-1A*	35,000	24,900	16.0	12.5	3881336
	CA*F3642*6D*+TXV	G*VC950714CXA*	34,600	24,600	15.5	12.0	4202531
	CA*F3642*6D*+TXV	A*VC950714CXA*	34,600	24,600	15.5	12.0	4202530
	CA*F3642*6D*+TXV	G*VC950905CXA*	34,600	24,600	15.5	12.0	4200646
	CA*F3642*6D*+TXV	A*VC950905CXA*	34,600	24,600	15.5	12.0	4200644
	CA*F3642*6D*+TXV	G*VC950915DXA*	34,600	24,600	15.5	12.0	4199980
	CA*F3642*6D*+TXV	A*VC950915DXA*	34,600	24,600	15.5	12.0	4199978
	CA*F3642*6D*+TXV	G*VC951155DXA*	34,600	24,600	16.0	12.3	3881367
	CA*F3642*6D*+TXV	G*VC950905DXA*	34,600	24,600	16.0	12.3	3881366
	CA*F3642*6D*+TXV	G*VC950704CXA*	34,600	24,600	15.5	12.0	3881365
	CA*F3642*6D*+TXV	G*VC950453BXA*	34,000	24,100	16.0	12.2	3881364
	CA*F3642*6D*+TXV	G*V951155DXA*	34,600	24,600	16.0	12.3	3881363
	CA*F3642*6D*+TXV	G*V950905DXA*	34,600	24,600	16.0	12.3	3881362
	CA*F3642*6D*+TXV	G*V950704CXA*	34,600	24,600	15.5	12.0	3881361
	CA*F3642*6D*+TXV	G*V950453B**	34,000	24,100	16.0	12.2	3881360
	CA*F3642*6D*+TXV	A*VC951155DXA*	34,600	24,600	16.0	12.3	3881359
	CA*F3642*6D*+TXV	A*VC950905DXA*	34,600	24,600	16.0	12.3	3881358
	CA*F3642*6D*+TXV	A*VC950704CXA*	34,600	24,600	15.5	12.0	3881357
	CA*F3642*6D*+TXV	A*VC950453BXA*	34,000	24,100	15.5	12.0	3881356
	CA*F3642*6D*+TXV	A*VC90905DXA*	34,600	24,600	16.0	12.3	3881355
	CA*F3642*6D*+TXV	A*VC90704CXA*	34,600	24,600	15.5	12.0	3881354
CA*F3642*6D*+TXV	A*VC80905CXA*	35,000	24,900	15.5	12.0	3881353	
CA*F3642*6D*+TXV	A*VC80704BXA*	34,000	24,100	16.0	12.5	3881352	
CA*F3642*6D*+TXV	A*V91155DX**	34,600	24,600	16.0	12.3	3881351	
CA*F3642*6D*+TXV	A*V90905DX**	34,600	24,600	16.0	12.3	3881350	
CA*F3642*6D*+TXV	A*V90704CX**	34,600	24,600	15.5	12.0	3881349	
CA*F3642*6D*+TXV	A*V90453B**	34,000	24,100	15.5	12.0	3881348	
CA*F3642*6D*+TXV	A*V81155CX**	34,600	24,600	15.5	12.0	3881347	

See Notes on Page 45.

AHRI PERFORMANCE DATA (CONT.)

OUTDOOR UNIT	INDOOR UNITS		COOLING CAPACITY (BTU/H)		SEER ¹	EER ²	AHRI #
	COIL/AIR HANDLER	FURNACE/BLOWER	TOTAL	SENSIBLE			
ASXC16 0361B* (cont.)	CA*F3642*6D*+TXV	A*V80905CX**	35,000	24,900	15.5	12.0	3881346
	CA*F3642*6D*+TXV	A*V80704B**	34,000	24,100	16.0	12.5	3881345
	CA*F3743*6A*+TXV	MBE1600**-1B*	35,000	24,900	16.0	12.5	3655073
	CA*F3743*6A*+TXV	MBVC1600**-1A*	35,000	24,900	16.0	12.5	3655074
	CA*F3743*6A*+TXV	G*VC950714CXA*	34,000	24,100	16.0	12.5	4202521
	CA*F3743*6A*+TXV	A*VC950714CXA*	34,000	24,100	16.0	12.5	4202520
	CA*F3743*6A*+TXV	G*VC950905CXA*	34,000	24,100	16.0	12.0	4200650
	CA*F3743*6A*+TXV	A*VC950905CXA*	34,000	24,100	16.0	12.0	4200648
	CA*F3743*6A*+TXV	G*VC950915DXA*	34,000	24,100	16.0	12.0	4199983
	CA*F3743*6A*+TXV	A*VC950915DXA*	34,000	24,100	16.0	12.0	4199982
	CA*F3743*6A*+TXV	G*VC951155DXA*	34,000	24,100	16.0	12.5	3655095
	CA*F3743*6A*+TXV	G*VC950905DXA*	34,000	24,100	16.0	12.5	3655094
	CA*F3743*6A*+TXV	G*VC950704CXA*	34,000	24,100	16.0	12.5	3655093
	CA*F3743*6A*+TXV	G*V951155D**	34,000	24,100	16.0	12.5	3655092
	CA*F3743*6A*+TXV	G*V950905D**	34,000	24,100	16.0	12.5	3655091
	CA*F3743*6A*+TXV	G*V950704C**	34,000	24,100	16.0	12.5	3655090
	CA*F3743*6A*+TXV	A*VC951155DXA*	34,000	24,100	16.0	12.5	3655089
	CA*F3743*6A*+TXV	A*VC950905DXA*	34,000	24,100	16.0	12.5	3655088
	CA*F3743*6A*+TXV	A*VC950704CXA*	34,000	24,100	16.0	12.5	3655087
	CA*F3743*6A*+TXV	A*VC950453BXA*	34,000	24,100	16.0	12.2	3655086
	CA*F3743*6A*+TXV	A*VC90905DXA*	34,000	24,100	16.0	12.5	3655085
	CA*F3743*6A*+TXV	A*VC90704CXA*	34,000	24,100	16.0	12.5	3655084
	CA*F3743*6A*+TXV	A*VC80905CXA*	34,000	24,100	16.0	12.5	3655083
	CA*F3743*6A*+TXV	A*VC80704BXA*	34,000	24,100	16.0	12.5	3655082
	CA*F3743*6A*+TXV	A*V91155D**	34,000	24,100	16.0	12.5	3655081
	CA*F3743*6A*+TXV	A*V90905D**	34,000	24,100	16.0	12.5	3655080
	CA*F3743*6A*+TXV	A*V90704C**	34,000	24,100	16.0	12.5	3655079
	CA*F3743*6A*+TXV	A*V90453B**	34,000	24,100	16.0	12.2	3655078
	CA*F3743*6A*+TXV	A*V81155C**	34,000	24,100	16.0	12.5	3655077
	CA*F3743*6A*+TXV	A*V80905C**	34,000	24,100	16.0	12.5	3655076
	CA*F3743*6A*+TXV	A*V80704B**	34,000	24,100	16.0	12.5	3655075
	CA*F3743*6D*+TXV	MBVC1600**-1A*	35,000	24,900	16.0	12.5	4415257
	CA*F3743*6D*+TXV	G*VC951155DXA*	34,000	24,100	16.0	12.5	4415301
	CA*F3743*6D*+TXV	G*VC950905DXA*	34,000	24,100	16.0	12.5	4415300
	CA*F3743*6D*+TXV	G*VC950905CXA*	34,000	24,100	16.0	12.0	4415299
	CA*F3743*6D*+TXV	G*VC950714CXA*	34,000	24,100	16.0	12.5	4415298
	CA*F3743*6D*+TXV	G*VC950704CXA*	34,000	24,100	16.0	12.5	4415297
	CA*F3743*6D*+TXV	A*VC951155DXA*	34,000	24,100	16.0	12.5	4415296
	CA*F3743*6D*+TXV	A*VC950905DXA*	34,000	24,100	16.0	12.5	4415295
	CA*F3743*6D*+TXV	A*VC950905CXA*	34,000	24,100	16.0	12.0	4415294
	CA*F3743*6D*+TXV	A*VC950714CXA*	34,000	24,100	16.0	12.5	4415293
	CA*F3743*6D*+TXV	A*VC950704CXA*	34,000	24,100	16.0	12.5	4415292
CA*F3743*6D*+TXV	A*VC90704CXA*	34,000	24,100	16.0	12.5	4415291	
CA*F3743*6D*+TXV	A*VC80905CXA*	34,000	24,100	16.0	12.5	4415290	
CA*F3743*6D*+TXV	A*VC80704BXA*	34,000	24,100	16.0	12.5	4415289	
CA*F4860*6B*+TXV	G*VC950714CXA*	34,600	24,600	16.0	12.2	4202523	
CA*F4860*6B*+TXV	A*VC950714CXA*	34,600	24,600	16.0	12.2	4202522	
CA*F4860*6B*+TXV	G*VC950905CXA*	35,000	24,900	15.5	12.0	4200654	
CA*F4860*6B*+TXV	A*VC950905CXA*	35,000	24,900	15.5	12.0	4200652	

See Notes on Page 45.

AHRI PERFORMANCE DATA (CONT.)

OUTDOOR UNIT	INDOOR UNITS		COOLING CAPACITY (BTU/H)		SEER ¹	EER ²	AHRI #
	COIL/AIR HANDLER	FURNACE/BLOWER	TOTAL	SENSIBLE			
ASXC16 0361B* (cont.)	CA*F4860*6B*+TXV	G*VC950915DXA*	35,000	24,900	15.5	12.0	4199987
	CA*F4860*6B*+TXV	A*VC950915DXA*	35,000	24,900	15.5	12.0	4199986
	CA*F4860*6B*+TXV	G*VC951155DXA*	35,000	24,900	16.0	12.5	3655117
	CA*F4860*6B*+TXV	G*VC950905DXA*	35,000	24,900	16.0	12.5	3655116
	CA*F4860*6B*+TXV	G*VC950704CXA*	34,600	24,600	16.0	12.2	3655115
	CA*F4860*6B*+TXV	G*VC950453BXA*	35,000	24,900	16.0	12.2	3655114
	CA*F4860*6B*+TXV	G*V951155D**	35,000	24,900	16.0	12.5	3655113
	CA*F4860*6B*+TXV	G*V950905D**	35,000	24,900	16.0	12.5	3655112
	CA*F4860*6B*+TXV	G*V950704C**	34,600	24,600	16.0	12.2	3655111
	CA*F4860*6B*+TXV	G*V950453B**	35,000	24,900	16.0	12.2	3655110
	CA*F4860*6B*+TXV	A*VC951155DXA*	35,000	24,900	16.0	12.5	3655109
	CA*F4860*6B*+TXV	A*VC950905DXA*	35,000	24,900	16.0	12.5	3655108
	CA*F4860*6B*+TXV	A*VC950704CXA*	34,600	24,600	16.0	12.2	3655107
	CA*F4860*6B*+TXV	A*VC950453BXA*	35,000	24,900	16.0	12.2	3655106
	CA*F4860*6B*+TXV	A*VC90905DXA*	35,000	24,900	16.0	12.5	3655105
	CA*F4860*6B*+TXV	A*VC90704CXA*	34,600	24,600	16.0	12.2	3655104
	CA*F4860*6B*+TXV	A*VC80905CXA*	35,000	24,900	16.0	12.5	3655103
	CA*F4860*6B*+TXV	A*VC80704BXA*	34,600	24,600	16.0	12.5	3655102
	CA*F4860*6B*+TXV	A*V91155D**	35,000	24,900	16.0	12.5	3655101
	CA*F4860*6B*+TXV	A*V90905D**	35,000	24,900	16.0	12.5	3655100
	CA*F4860*6B*+TXV	A*V90704C**	34,600	24,600	16.0	12.2	3655099
	CA*F4860*6B*+TXV	A*V90453B**	35,000	24,900	16.0	12.2	3655098
	CA*F4860*6B*+TXV	A*V80905C**	35,000	24,900	16.0	12.5	3655097
	CA*F4860*6B*+TXV	A*V80704B**	34,600	24,600	16.0	12.5	3655096
	CA*F4860*6D*+TXV	G*VC950714CXA*	34,600	24,600	16.0	12.2	4202533
	CA*F4860*6D*+TXV	A*VC950714CXA*	34,600	24,600	16.0	12.2	4202532
	CA*F4860*6D*+TXV	G*VC950905CXA*	35,000	24,900	15.5	12.0	4200657
	CA*F4860*6D*+TXV	A*VC950905CXA*	35,000	24,900	15.5	12.0	4200655
	CA*F4860*6D*+TXV	G*VC950915DXA*	35,000	24,900	15.5	12.0	4199991
	CA*F4860*6D*+TXV	A*VC950915DXA*	35,000	24,900	15.5	12.0	4199989
	CA*F4860*6D*+TXV	G*VC951155DXA*	35,000	24,900	16.0	12.5	3881396
	CA*F4860*6D*+TXV	G*VC950905DXA*	35,000	24,900	16.0	12.5	3881395
	CA*F4860*6D*+TXV	G*VC950704CXA*	34,600	24,600	16.0	12.2	3881394
	CA*F4860*6D*+TXV	G*VC950453BXA*	35,000	24,900	16.0	12.2	3881393
	CA*F4860*6D*+TXV	G*V951155DXA*	35,000	24,900	16.0	12.5	3881392
	CA*F4860*6D*+TXV	G*V950905DXA*	35,000	24,900	16.0	12.5	3881391
	CA*F4860*6D*+TXV	G*V950704CXA*	34,600	24,600	16.0	12.2	3881390
	CA*F4860*6D*+TXV	G*V950453B**	35,000	24,900	16.0	12.2	3881389
	CA*F4860*6D*+TXV	A*VC951155DXA*	35,000	24,900	16.0	12.5	3881388
	CA*F4860*6D*+TXV	A*VC950905DXA*	35,000	24,900	16.0	12.5	3881387
	CA*F4860*6D*+TXV	A*VC950704CXA*	34,600	24,600	16.0	12.2	3881386
	CA*F4860*6D*+TXV	A*VC950453BXA*	35,000	24,900	16.0	12.2	3881385
CA*F4860*6D*+TXV	A*VC90905DXA*	35,000	24,900	16.0	12.5	3881384	
CA*F4860*6D*+TXV	A*VC90704CXA*	34,600	24,600	16.0	12.2	3881383	
CA*F4860*6D*+TXV	A*VC80905CXA*	35,000	24,900	16.0	12.5	3881382	
CA*F4860*6D*+TXV	A*VC80704BXA*	34,600	24,600	16.0	12.5	3881381	
CA*F4860*6D*+TXV	A*V91155DX**	35,000	24,900	16.0	12.5	3881380	
CA*F4860*6D*+TXV	A*V90905DX**	35,000	24,900	16.0	12.5	3881379	
CA*F4860*6D*+TXV	A*V90704CX**	34,600	24,600	16.0	12.2	3881378	

See Notes on Page 45.

AHRI PERFORMANCE DATA (CONT.)

OUTDOOR UNIT	INDOOR UNITS		COOLING CAPACITY (BTU/H)		SEER ¹	EER ²	AHRI #
	COIL/AIR HANDLER	FURNACE/BLOWER	TOTAL	SENSIBLE			
ASXC16 0361B* (cont.)	CA*F4860*6D*+TXV	A*V90453B**	35,000	24,900	16.0	12.2	3881377
	CA*F4860*6D*+TXV	A*V80905CX**	35,000	24,900	16.0	12.5	3881376
	CA*F4860*6D*+TXV	A*V80704B**	34,600	24,600	16.0	12.5	3881375
	CHPF3642C6C*+TXV	MBE1600**-1B*	34,600	24,600	16.0	12.5	3655118
	CHPF3642C6C*+TXV	MBVC1600**-1A*	34,600	24,600	16.0	12.5	3655119
	CHPF3642C6C*+TXV	A*VC950714CXA*	34,600	24,600	16.0	12.0	4202524
	CHPF3642C6C*+TXV	A*VC950704CXA*	34,600	24,600	16.0	12.0	3655127
	CHPF3642C6C*+TXV	A*VC90704CXA*	34,600	24,600	16.0	12.0	3655126
	CHPF3642C6C*+TXV	A*VC80905CXA*	34,600	24,600	16.0	12.5	3655125
	CHPF3642C6C*+TXV	A*VC80704BXA*	34,000	24,100	15.5	12.0	3655124
	CHPF3642C6C*+TXV	A*V90704C**	34,600	24,600	16.0	12.0	3655123
	CHPF3642C6C*+TXV	A*V81155C**	34,600	24,600	16.0	12.5	3655122
	CHPF3642C6C*+TXV	A*V80905C**	34,600	24,600	16.0	12.5	3655121
	CHPF3642C6C*+TXV	A*V80704B**	34,000	24,100	15.5	12.0	3655120
	CHPF3642D6C*+TXV	MBE2000**-1B*	35,000	24,900	16.0	12.8	3655128
	CHPF3642D6C*+TXV	MBVC2000**-1A*	35,000	24,900	16.0	12.8	3655129
	CHPF3642D6C*+TXV	G*VC950915DXA*	34,600	24,600	16.0	12.0	4594830
	CHPF3642D6C*+TXV	A*VC950905CXA*	34,600	24,600	16.0	12.0	4200659
	CHPF3642D6C*+TXV	A*VC950915DXA*	34,600	24,600	16.0	12.0	4199993
	CHPF3642D6C*+TXV	A*VC951155DXA*	34,600	24,600	16.0	12.5	3655134
	CHPF3642D6C*+TXV	A*VC950905DXA*	34,600	24,600	16.0	12.5	3655133
	CHPF3642D6C*+TXV	A*VC90905DXA*	34,600	24,600	16.0	12.5	3655132
	CHPF3642D6C*+TXV	A*V91155D**	34,600	24,600	16.0	12.5	3655131
	CHPF3642D6C*+TXV	A*V90905D**	34,600	24,600	16.0	12.5	3655130
	CHPF3743C6B*+TXV	MBE1600**-1B*	34,600	24,600	16.0	12.5	3655135
	CHPF3743C6B*+TXV	MBE2000**-1B*	35,000	24,900	16.0	12.8	3655136
	CHPF3743C6B*+TXV	MBVC1600**-1A*	34,600	24,600	16.0	12.5	3655137
	CHPF3743C6B*+TXV	MBVC2000**-1A*	35,000	24,900	16.0	12.8	3655138
	CHPF3743C6B*+TXV	G*VC950915DXA*	34,600	24,600	16.0	12.0	4594831
	CHPF3743C6B*+TXV	A*VC950714CXA*	34,600	24,600	16.0	12.0	4202525
	CHPF3743C6B*+TXV	A*VC950905CXA*	34,600	24,600	16.0	12.0	4200661
	CHPF3743C6B*+TXV	A*VC950915DXA*	34,600	24,600	16.0	12.0	4199995
	CHPF3743C6B*+TXV	A*VC951155DXA*	34,600	24,600	16.0	12.5	3655153
	CHPF3743C6B*+TXV	A*VC950905DXA*	34,600	24,600	16.0	12.5	3655152
	CHPF3743C6B*+TXV	A*VC950704CXA*	34,600	24,600	16.0	12.0	3655151
	CHPF3743C6B*+TXV	A*VC950453BXA*	34,000	24,100	16.0	12.2	3655150
	CHPF3743C6B*+TXV	A*VC90905DXA*	34,600	24,600	16.0	12.5	3655149
	CHPF3743C6B*+TXV	A*VC90704CXA*	34,600	24,600	16.0	12.0	3655148
	CHPF3743C6B*+TXV	A*VC80905CXA*	34,600	24,600	16.0	12.5	3655147
	CHPF3743C6B*+TXV	A*VC80704BXA*	34,000	24,100	15.5	12.0	3655146
	CHPF3743C6B*+TXV	A*V91155D**	34,600	24,600	16.0	12.5	3655145
	CHPF3743C6B*+TXV	A*V90905D**	34,600	24,600	16.0	12.5	3655144
CHPF3743C6B*+TXV	A*V90704C**	34,600	24,600	16.0	12.0	3655143	
CHPF3743C6B*+TXV	A*V90453B**	34,000	24,100	16.0	12.2	3655142	
CHPF3743C6B*+TXV	A*V81155C**	34,600	24,600	16.0	12.5	3655141	
CHPF3743C6B*+TXV	A*V80905C**	34,600	24,600	16.0	12.5	3655140	
CHPF3743C6B*+TXV	A*V80704B**	34,000	24,100	15.5	12.0	3655139	
CHPF3743D6B*+TXV	MBE2000**-1B*	35,000	24,900	16.0	12.8	3655154	
CHPF3743D6B*+TXV	MBVC2000**-1A*	35,000	24,900	16.0	12.8	3655155	

See Notes on Page 45.

AHRI PERFORMANCE DATA (CONT.)

OUTDOOR UNIT	INDOOR UNITS		COOLING CAPACITY (BTU/H)		SEER ¹	EER ²	AHRI #
	COIL/AIR HANDLER	FURNACE/BLOWER	TOTAL	SENSIBLE			
ASXC16 0361B* (cont.)	CHPF3743D6B*+TXV	G*VC950915DXA*	34,600	24,600	16.0	12.0	4594832
	CHPF3743D6B*+TXV	A*VC950714CXA*	34,000	24,100	16.0	12.2	4202526
	CHPF3743D6B*+TXV	A*VC950905CXA*	34,600	24,600	16.0	12.0	4200662
	CHPF3743D6B*+TXV	A*VC950915DXA*	34,600	24,600	16.0	12.0	4199997
	CHPF3743D6B*+TXV	A*VC951155DXA*	34,600	24,600	16.0	12.5	3655170
	CHPF3743D6B*+TXV	A*VC950905DXA*	34,600	24,600	16.0	12.5	3655169
	CHPF3743D6B*+TXV	A*VC950704CXA*	34,000	24,100	16.0	12.2	3655168
	CHPF3743D6B*+TXV	A*VC950453BXA*	34,000	24,100	16.0	12.2	3655167
	CHPF3743D6B*+TXV	A*VC90905DXA*	34,600	24,600	16.0	12.5	3655166
	CHPF3743D6B*+TXV	A*VC90704CXA*	34,000	24,100	16.0	12.2	3655165
	CHPF3743D6B*+TXV	A*VC80905CXA*	34,000	24,100	16.0	12.5	3655164
	CHPF3743D6B*+TXV	A*VC80704BXA*	34,000	24,100	16.0	12.5	3655163
	CHPF3743D6B*+TXV	A*V91155D**	34,600	24,600	16.0	12.5	3655162
	CHPF3743D6B*+TXV	A*V90905D**	34,600	24,600	16.0	12.5	3655161
	CHPF3743D6B*+TXV	A*V90704C**	34,000	24,100	16.0	12.2	3655160
	CHPF3743D6B*+TXV	A*V90453B**	34,000	24,100	16.0	12.2	3655159
	CHPF3743D6B*+TXV	A*V81155C**	34,000	24,100	16.0	12.5	3655158
	CHPF3743D6B*+TXV	A*V80905C**	34,000	24,100	16.0	12.5	3655157
	CHPF3743D6B*+TXV	A*V80704B**	34,000	24,100	16.0	12.5	3655156
	CHPF4860D6D*+TXV	G*VC950915DXA*	35,000	24,900	16.0	12.0	4594833
	CHPF4860D6D*+TXV	A*VC950714CXA*	35,000	24,900	16.0	12.2	4202527
	CHPF4860D6D*+TXV	A*VC950905CXA*	35,000	24,900	16.0	12.0	4200665
	CHPF4860D6D*+TXV	A*VC950915DXA*	35,000	24,900	16.0	12.0	4199998
	CHPF4860D6D*+TXV	A*VC951155DXA*	35,000	24,900	16.0	12.5	3655185
	CHPF4860D6D*+TXV	A*VC950905DXA*	35,000	24,900	16.0	12.5	3655184
	CHPF4860D6D*+TXV	A*VC950704CXA*	35,000	24,900	16.0	12.2	3655183
	CHPF4860D6D*+TXV	A*VC950453BXA*	34,600	24,600	16.0	12.2	3655182
	CHPF4860D6D*+TXV	A*VC90905DXA*	35,000	24,900	16.0	12.5	3655181
	CHPF4860D6D*+TXV	A*VC90704CXA*	35,000	24,900	16.0	12.2	3655180
	CHPF4860D6D*+TXV	A*VC80905CXA*	34,600	24,600	16.0	12.5	3655179
	CHPF4860D6D*+TXV	A*VC80704BXA*	34,600	24,600	16.0	12.5	3655178
	CHPF4860D6D*+TXV	A*V91155D**	35,000	24,900	16.0	12.5	3655177
	CHPF4860D6D*+TXV	A*V90905D**	35,000	24,900	16.0	12.5	3655176
	CHPF4860D6D*+TXV	A*V90704C**	35,000	24,900	16.0	12.2	3655175
	CHPF4860D6D*+TXV	A*V90453B**	34,600	24,600	16.0	12.2	3655174
	CHPF4860D6D*+TXV	A*V81155C**	35,000	24,900	16.0	12.5	3655173
	CHPF4860D6D*+TXV	A*V80905C**	34,600	24,600	16.0	12.5	3655172
	CHPF4860D6D*+TXV	A*V80704B**	34,600	24,600	16.0	12.5	3655171
	CSCF3642N6C*+TXV	G*VC950915DXA*	34,600	24,600	16.0	12.0	4594834
	CSCF3642N6C*+TXV	A*VC950714CXA*	34,200	24,300	16.0	12.0	4202528
	CSCF3642N6C*+TXV	A*VC950905CXA*	34,600	24,600	16.0	12.0	4200667
	CSCF3642N6C*+TXV	A*VC950915DXA*	34,600	24,600	16.0	12.0	4200001
	CSCF3642N6C*+TXV	A*VC951155DXA*	34,600	24,600	16.0	12.2	3655201
	CSCF3642N6C*+TXV	A*VC950905DXA*	34,600	24,600	16.0	12.2	3655200
	CSCF3642N6C*+TXV	A*VC950704CXA*	34,200	24,300	16.0	12.0	3655199
	CSCF3642N6C*+TXV	A*VC950453BXA*	34,000	24,100	16.0	12.2	3655198
	CSCF3642N6C*+TXV	A*VC90905DXA*	34,600	24,600	16.0	12.2	3655197
	CSCF3642N6C*+TXV	A*VC90704CXA*	34,200	24,300	16.0	12.0	3655196
CSCF3642N6C*+TXV	A*VC80905CXA*	34,200	24,300	16.0	12.3	3655195	

See Notes on Page 45.

AHRI PERFORMANCE DATA (CONT.)

OUTDOOR UNIT	INDOOR UNITS		COOLING CAPACITY (BTU/H)		SEER ¹	EER ²	AHRI #
	COIL/AIR HANDLER	FURNACE/BLOWER	TOTAL	SENSIBLE			
ASXC16 0361B* (cont.)	CSCF3642N6C*+TXV	A*VC80704BXA*	34,000	24,100	16.0	12.5	3655194
	CSCF3642N6C*+TXV	A*V91155D**	34,600	24,600	16.0	12.2	3655193
	CSCF3642N6C*+TXV	A*V90905D**	34,600	24,600	16.0	12.2	3655192
	CSCF3642N6C*+TXV	A*V90704C**	34,200	24,300	16.0	12.0	3655191
	CSCF3642N6C*+TXV	A*V90453B**	34,000	24,100	16.0	12.2	3655190
	CSCF3642N6C*+TXV	A*V81155C**	34,200	24,300	16.0	12.3	3655189
	CSCF3642N6C*+TXV	A*V80905C**	34,200	24,300	16.0	12.3	3655188
	CSCF3642N6C*+TXV	A*V80704B**	34,000	24,100	16.0	12.5	3655187
	CSCF4860N6C*+TXV	G*VC950915DXA*	35,000	24,900	16.0	12.0	4594835
	CSCF4860N6C*+TXV	A*VC950714CXA*	35,000	24,900	16.0	12.5	4202529
	CSCF4860N6C*+TXV	A*VC950905CXA*	35,000	24,900	16.0	12.0	4200668
	CSCF4860N6C*+TXV	A*VC950915DXA*	35,000	24,900	16.0	12.0	4200003
	CSCF4860N6C*+TXV	A*VC951155DXA*	35,000	24,900	16.0	12.5	3655216
	CSCF4860N6C*+TXV	A*VC950905DXA*	35,000	24,900	16.0	12.5	3655215
	CSCF4860N6C*+TXV	A*VC950704CXA*	35,000	24,900	16.0	12.5	3655214
	CSCF4860N6C*+TXV	A*VC950453BXA*	35,000	24,900	16.0	12.2	3655213
	CSCF4860N6C*+TXV	A*VC90905DXA*	35,000	24,900	16.0	12.5	3655212
	CSCF4860N6C*+TXV	A*VC90704CXA*	35,000	24,900	16.0	12.5	3655211
	CSCF4860N6C*+TXV	A*VC80905CXA*	34,600	24,600	16.0	12.5	3655210
	CSCF4860N6C*+TXV	A*VC80704BXA*	35,000	24,900	16.0	12.5	3655209
	CSCF4860N6C*+TXV	A*V91155D**	35,000	24,900	16.0	12.5	3655208
	CSCF4860N6C*+TXV	A*V90905D**	35,000	24,900	16.0	12.5	3655207
	CSCF4860N6C*+TXV	A*V90704C**	35,000	24,900	16.0	12.5	3655206
	CSCF4860N6C*+TXV	A*V90453B**	35,000	24,900	16.0	12.2	3655205
	CSCF4860N6C*+TXV	A*V81155C**	35,000	24,900	16.0	12.5	3655204
	CSCF4860N6C*+TXV	A*V80905C**	34,600	24,600	16.0	12.5	3655203
	CSCF4860N6C*+TXV	A*V80704B**	35,000	24,900	16.0	12.5	3655202
	CT*F3636*6A*+TXV	MBE1600**-1B*	34,600	24,600	16.0	12.5	3655217
	CT*F3636*6A*+TXV	MBVC1600**-1A*	34,600	24,600	16.0	12.5	3655218
	ASXC16 0481A*	AEPF426016C*+TXV		46,000	35,000	12	15.5
AVPTC426014A*			46,000	35,000	12	15.5	4431353
CA*F4860*6B*+TXV		MBE1600**-1B*	46,000	35,000	12	15	3610659
CA*F4860*6B*+TXV		MBE2000**-1B*	47,000	35,700	12.5	16	3610661
CA*F4860*6B*+TXV		MBVC1600**-1A*	46,000	35,000	12	15	3610609
CA*F4860*6B*+TXV		MBVC2000**-1A*	47,000	35,700	12.5	16	3610610
CA*F4860*6B*+TXV		A*VC950714CXA*	45,500	34,600	12	15	4202534
CA*F4860*6B*+TXV		G*VC950905CXA*	47,000	35,700	11.5	15	4200672
CA*F4860*6B*+TXV		A*VC950905CXA*	47,000	35,700	11.5	15	4200670
CA*F4860*6B*+TXV		G*VC950915DXA*	47,000	35,700	11.5	15	4200006
CA*F4860*6B*+TXV		A*VC950915DXA*	47,000	35,700	11.5	15	4200004
CA*F4860*6B*+TXV		A*VC81155CXA*	46,500	35,300	12	16	3642634
CA*F4860*6B*+TXV		A*VC80704BXA*	45,500	34,600	12	15	3642619
CA*F4860*6B*+TXV		A*VC80905CXA*	47,000	35,700	12.25	16	3630030
CA*F4860*6B*+TXV		G*VC951155DXA*	47,000	35,700	12.25	16	3610502
CA*F4860*6B*+TXV		G*VC950905DXA*	47,000	35,700	12.25	16	3610501
CA*F4860*6B*+TXV		G*V951155D**	47,000	35,700	12.25	16	3610500
CA*F4860*6B*+TXV		G*V950905D**	47,000	35,700	12.25	16	3610499
CA*F4860*6B*+TXV		A*VC951155DXA*	47,000	35,700	12.5	16	3610498
CA*F4860*6B*+TXV		A*VC950905DXA*	47,000	35,700	12.25	16	3610497

See Notes on Page 45.

AHRI PERFORMANCE DATA (CONT.)

OUTDOOR UNIT	INDOOR UNITS		COOLING CAPACITY (BTU/H)		SEER ¹	EER ²	AHRI #
	COIL/AIR HANDLER	FURNACE/BLOWER	TOTAL	SENSIBLE			
ASXC16 0481A* (cont.)	CA*F4860*6B*+TXV	A*VC90905DXA*	47,000	35,700	12.25	16	3610496
	CA*F4860*6B*+TXV	A*V91155D**	47,000	35,700	12.5	16	3610495
	CA*F4860*6B*+TXV	A*V90905D**	47,000	35,700	12.25	16	3610494
	CA*F4860*6B*+TXV	A*V80905C**	47,000	35,700	12.25	16	3610493
	CA*F4860*6B*+TXV	A*V81155C**	46,500	35,300	12.5	16	3610487
	CA*F4860*6B*+TXV	A*VC950704CXA*	45,500	34,600	12	15	3610455
	CA*F4860*6B*+TXV	A*VC90704CXA*	45,500	34,600	12	15	3610454
	CA*F4860*6B*+TXV	A*V90704C**	45,500	34,600	12	15	3610453
	CA*F4860*6B*+TXV	A*V80704B**	45,500	34,600	12	15	3610452
	CA*F4860*6D*+TXV	MBE1600**-1B*	46,000	35,000	12	15	3881368
	CA*F4860*6D*+TXV	MBVC1600**-1A*	46,000	35,000	12	15	3881371
	CA*F4860*6D*+TXV	MBVC2000**-1A*	47,000	35,700	12.5	16	3881372
	CA*F4860*6D*+TXV	A*VC950714CXA*	45,500	34,600	12	15	4202538
	CA*F4860*6D*+TXV	G*VC950905CXA*	47,000	35,700	11.5	15	4200676
	CA*F4860*6D*+TXV	A*VC950905CXA*	47,000	35,700	11.5	15	4200674
	CA*F4860*6D*+TXV	G*VC950915DXA*	47,000	35,700	11.5	15	4200010
	CA*F4860*6D*+TXV	A*VC950915DXA*	47,000	35,700	11.5	15	4200008
	CA*F4860*6D*+TXV	G*VC951155DXA*	47,000	35,700	12.25	16	3881414
	CA*F4860*6D*+TXV	G*VC950905DXA*	47,000	35,700	12.25	16	3881413
	CA*F4860*6D*+TXV	G*V951155DXA*	47,000	35,700	12.25	16	3881412
	CA*F4860*6D*+TXV	G*V950905DXA*	47,000	35,700	12.25	16	3881411
	CA*F4860*6D*+TXV	A*VC951155DXA*	47,000	35,700	12.5	16	3881410
	CA*F4860*6D*+TXV	A*VC950905DXA*	47,000	35,700	12.25	16	3881409
	CA*F4860*6D*+TXV	A*VC950704CXA*	45,500	34,600	12	15	3881408
	CA*F4860*6D*+TXV	A*VC90905DXA*	47,000	35,700	12.25	16	3881407
	CA*F4860*6D*+TXV	A*VC90704CXA*	45,500	34,600	12	15	3881406
	CA*F4860*6D*+TXV	A*VC81155CXA*	46,500	35,300	12	16	3881405
	CA*F4860*6D*+TXV	A*VC80905CXA*	47,000	35,700	12.25	16	3881404
	CA*F4860*6D*+TXV	A*VC80704BXA*	45,500	34,600	12	15	3881403
	CA*F4860*6D*+TXV	A*V91155DX**	47,000	35,700	12.5	16	3881402
	CA*F4860*6D*+TXV	A*V90905DX**	47,000	35,700	12.25	16	3881401
	CA*F4860*6D*+TXV	A*V90704CX**	45,500	34,600	12	15	3881400
	CA*F4860*6D*+TXV	A*V81155CX**	46,500	35,300	12.5	16	3881399
	CA*F4860*6D*+TXV	A*V80905CX**	47,000	35,700	12.25	16	3881398
	CA*F4860*6D*+TXV	A*V80704B**	45,500	34,600	12	15	3881397
	CA*F4961*6A*+TXV	MBE1600**-1B*	46,000	35,000	12	15	3610660
	CA*F4961*6A*+TXV	MBE2000**-1B*	47,000	35,700	12.5	16	3610662
	CA*F4961*6A*+TXV	MBVC1600**-1A*	46,000	35,000	12	15	3610611
	CA*F4961*6A*+TXV	MBVC2000**-1A*	47,000	35,700	12.5	16	3610612
	CA*F4961*6A*+TXV	A*VC950714CXA*	46,500	35,300	12	15	4202537
	CA*F4961*6A*+TXV	G*VC950905CXA*	47,000	35,700	12	15.5	4200680
	CA*F4961*6A*+TXV	A*VC950905CXA*	47,000	35,700	12	15.5	4200678
	CA*F4961*6A*+TXV	G*VC950915DXA*	47,000	35,700	12	15.5	4200014
	CA*F4961*6A*+TXV	A*VC950915DXA*	47,000	35,700	12	15.5	4200013
	CA*F4961*6A*+TXV	A*VC81155CXA*	46,500	35,300	12	16	3642636
	CA*F4961*6A*+TXV	A*VC80704BXA*	46,000	35,000	12.2	15.5	3642628
	CA*F4961*6A*+TXV	A*VC80905CXA*	47,000	35,700	12.5	16	3630031
	CA*F4961*6A*+TXV	G*VC951155DXA*	47,000	35,700	12.5	16	3610512
CA*F4961*6A*+TXV	G*VC950905DXA*	47,000	35,700	12.5	16	3610511	

See Notes on Page 45.

AHRI PERFORMANCE DATA (CONT.)

OUTDOOR UNIT	INDOOR UNITS		COOLING CAPACITY (BTU/H)		SEER ¹	EER ²	AHRI #
	COIL/AIR HANDLER	FURNACE/BLOWER	TOTAL	SENSIBLE			
ASXC16 0481A* (cont.)	CA*F4961*6A*+TXV	G*V951155D**	47,000	35,700	12.5	16	3610510
	CA*F4961*6A*+TXV	G*V950905D**	47,000	35,700	12.5	16	3610509
	CA*F4961*6A*+TXV	A*VC951155DXA*	47,000	35,700	12.5	16	3610508
	CA*F4961*6A*+TXV	A*VC950905DXA*	47,000	35,700	12.5	16	3610507
	CA*F4961*6A*+TXV	A*VC90905DXA*	47,000	35,700	12.5	16	3610506
	CA*F4961*6A*+TXV	A*V91155D**	47,000	35,700	12.5	16	3610505
	CA*F4961*6A*+TXV	A*V90905D**	47,000	35,700	12.5	16	3610504
	CA*F4961*6A*+TXV	A*V80905C**	47,000	35,700	12.5	16	3610503
	CA*F4961*6A*+TXV	A*VC950704CXA*	46,500	35,300	12	15	3610491
	CA*F4961*6A*+TXV	A*VC90704CXA*	46,500	35,300	12	15	3610490
	CA*F4961*6A*+TXV	A*V90704C**	46,500	35,300	12	15	3610489
	CA*F4961*6A*+TXV	A*V81155C**	46,500	35,300	12.5	16	3610488
	CA*F4961*6A*+TXV	A*V80704B**	46,000	35,000	12.2	15.5	3610466
	CA*F4961*6D*+TXV	MBVC1600** -1A*	46,000	35,000	12	15	4431404
	CA*F4961*6D*+TXV	MBVC2000** -1A*	47,000	35,700	12.5	16	4431405
	CA*F4961*6D*+TXV	G*VC951155DXA*	47,000	35,700	12.5	16	4431422
	CA*F4961*6D*+TXV	G*VC950905DXA*	47,000	35,700	12.5	16	4431421
	CA*F4961*6D*+TXV	G*VC950905CXA*	47,000	35,700	12	15.5	4431420
	CA*F4961*6D*+TXV	A*VC951155DXA*	47,000	35,700	12.5	16	4431419
	CA*F4961*6D*+TXV	A*VC950905DXA*	47,000	35,700	12.5	16	4431418
	CA*F4961*6D*+TXV	A*VC950905CXA*	47,000	35,700	12	15.5	4431417
	CA*F4961*6D*+TXV	A*VC950714CXA*	46,500	35,300	12	15	4431416
	CA*F4961*6D*+TXV	A*VC950704CXA*	46,500	35,300	12	15	4431415
	CA*F4961*6D*+TXV	A*VC90905DXA*	47,000	35,700	12.5	16	4431414
	CA*F4961*6D*+TXV	A*VC90704CXA*	46,500	35,300	12	15	4431413
	CA*F4961*6D*+TXV	A*VC81155CXA*	46,500	35,300	12	16	4431412
	CA*F4961*6D*+TXV	A*VC80905CXA*	47,000	35,700	12.5	16	4431411
	CA*F4961*6D*+TXV	A*VC80704BXA*	46,000	35,000	12.2	15.5	4431410
	CHPF4860D6D*+TXV	MBE1600** -1B*	46,000	35,000	12	15	3610470
	CHPF4860D6D*+TXV	MBE2000** -1B*	47,000	35,700	12.5	16	3610520
	CHPF4860D6D*+TXV	MBVC1600** -1A*	46,000	35,000	12	15	3610613
	CHPF4860D6D*+TXV	MBVC2000** -1A*	47,000	35,700	12.5	16	3610614
	CHPF4860D6D*+TXV	G*VC950915DXA*	47,000	35,700	12.25	16	4594836
	CHPF4860D6D*+TXV	A*VC950714CXA*	46,000	35,000	12	15.5	4202536
	CHPF4860D6D*+TXV	A*VC950905CXA*	47,000	35,700	12.25	16	4200682
	CHPF4860D6D*+TXV	A*VC950915DXA*	47,000	35,700	12.25	16	4200016
	CHPF4860D6D*+TXV	G*VC81155CXA*	45,500	34,600	12	15.5	3642626
	CHPF4860D6D*+TXV	A*VC81155CXA*	45,500	34,600	12	15.5	3642624
	CHPF4860D6D*+TXV	A*VC80704BXA*	45,500	34,600	12	15.5	3642620
	CHPF4860D6D*+TXV	G*VC80905CXA*	45,500	34,600	12	15.5	3630018
	CHPF4860D6D*+TXV	A*VC80905CXA*	45,500	34,600	12	15.5	3630016
	CHPF4860D6D*+TXV	A*VC951155DXA*	47,000	35,700	12.25	16	3610525
	CHPF4860D6D*+TXV	A*VC950905DXA*	47,000	35,700	12.25	16	3610524
	CHPF4860D6D*+TXV	A*VC90905DXA*	47,000	35,700	12.25	16	3610523
	CHPF4860D6D*+TXV	A*V91155D**	47,000	35,700	12.25	16	3610522
	CHPF4860D6D*+TXV	A*V90905D**	47,000	35,700	12.25	16	3610521
	CHPF4860D6D*+TXV	A*VC950704CXA*	46,000	35,000	12	15.5	3610474
	CHPF4860D6D*+TXV	A*VC90704CXA*	46,000	35,000	12	15.5	3610473
CHPF4860D6D*+TXV	A*V90704C**	46,000	35,000	12	15.5	3610472	

See Notes on Page 45.

AHRI PERFORMANCE DATA (CONT.)

OUTDOOR UNIT	INDOOR UNITS		COOLING CAPACITY (BTU/H)		SEER ¹	EER ²	AHRI #
	COIL/AIR HANDLER	FURNACE/BLOWER	TOTAL	SENSIBLE			
ASXC16 0481A* (cont.)	CHPF4860D6D*+TXV	G*V81155C**	45,500	34,600	12	15.5	3610460
	CHPF4860D6D*+TXV	G*V80905C**	45,500	34,600	12	15.5	3610459
	CHPF4860D6D*+TXV	A*V81155C**	45,500	34,600	12	15.5	3610458
	CHPF4860D6D*+TXV	A*V80905C**	45,500	34,600	12	15.5	3610457
	CHPF4860D6D*+TXV	A*V80704B**	45,500	34,600	12	15.5	3610456
	CSCF4860N6C*+TXV	G*VC950915DXA*	46,000	35,000	12.5	16	4594837
	CSCF4860N6C*+TXV	A*VC950714CXA*	45,500	34,600	12	15	4202535
	CSCF4860N6C*+TXV	A*VC950905CXA*	46,000	35,000	12.5	16	4200684
	CSCF4860N6C*+TXV	A*VC950915DXA*	46,000	35,000	12.5	16	4200018
	CSCF4860N6C*+TXV	A*VC81155CXA*	46,000	35,000	12	15.5	3642631
	CSCF4860N6C*+TXV	A*VC80704BXA*	45,500	34,600	12	15.5	3642622
	CSCF4860N6C*+TXV	A*VC80905CXA*	47,000	35,700	12.25	16	3630032
	CSCF4860N6C*+TXV	A*V80905C**	47,000	35,700	12.25	16	3610529
	CSCF4860N6C*+TXV	A*VC951155DXA*	46,000	35,000	12.5	16	3610483
	CSCF4860N6C*+TXV	A*VC950905DXA*	46,000	35,000	12.5	16	3610482
	CSCF4860N6C*+TXV	A*VC90905DXA*	46,000	35,000	12.5	16	3610481
	CSCF4860N6C*+TXV	A*V91155D**	46,000	35,000	12.5	16	3610480
	CSCF4860N6C*+TXV	A*V90905D**	46,000	35,000	12.5	16	3610479
	CSCF4860N6C*+TXV	A*V81155C**	46,000	35,000	12	15.5	3610478
	CSCF4860N6C*+TXV	A*VC950704CXA*	45,500	34,600	12	15	3610464
CSCF4860N6C*+TXV	A*VC90704CXA*	45,500	34,600	12	15	3610463	
CSCF4860N6C*+TXV	A*V90704C**	45,500	34,600	12	15	3610462	
CSCF4860N6C*+TXV	A*V80704B**	45,500	34,600	12	15.5	3610461	
ASXC16 0481B*	AEPF426016C*+TXV		46,000	35,000	12	15.5	4172372
	AVPTC426014A*		46,000	35,000	12	15.5	4431352
	CA*F4860*6B*+TXV	G*VC951155DXA*	46,000	35,000	12.3	16	4172390
	CA*F4860*6B*+TXV	G*VC950905DXA*	46,000	35,000	12.3	16	4172389
	CA*F4860*6B*+TXV	G*VC950704CXA*	45,500	34,600	12	15	4172388
	CA*F4860*6B*+TXV	G*VC90905DXA*	46,000	35,000	12.3	16	4172387
	CA*F4860*6B*+TXV	G*VC90704CXA*	45,500	34,600	12	15	4172386
	CA*F4860*6B*+TXV	G*VC81155CXA*	46,000	35,000	12	16	4172385
	CA*F4860*6B*+TXV	G*VC80905CXA*	46,000	35,000	12.3	16	4172384
	CA*F4860*6B*+TXV	G*VC80704BXA*	45,500	34,600	12	15	4172383
	CA*F4860*6B*+TXV	A*VC951155DXA*	46,000	35,000	12.5	16	4172382
	CA*F4860*6B*+TXV	A*VC950905DXA*	46,000	35,000	12.3	16	4172381
	CA*F4860*6B*+TXV	A*VC950704CXA*	45,500	34,600	12	15	4172380
	CA*F4860*6B*+TXV	A*VC90905DXA*	46,000	35,000	12.3	16	4172379
	CA*F4860*6B*+TXV	A*VC90704CXA*	45,500	34,600	12	15	4172378
	CA*F4860*6B*+TXV	A*VC81155CXA*	46,000	35,000	12	16	4172377
	CA*F4860*6B*+TXV	A*VC80905CXA*	46,000	35,000	12.3	16	4172376
	CA*F4860*6B*+TXV	A*VC80704BXA*	45,500	34,600	12	15	4172375
	CA*F4860*6B*+TXV	MBVC2000** -1A*	47,000	35,700	12.5	16	4172374
	CA*F4860*6B*+TXV	MBVC1600** -1A*	46,000	35,000	12	15	4172373
	CA*F4860*6D*+TXV	MBVC2000** -1A*	47,000	35,700	12.5	16	4559619
	CA*F4860*6D*+TXV	MBVC1600** -1A*	46,000	35,000	12	15	4559618
	CA*F4860*6D*+TXV	G*VC951155DXA*	46,000	35,000	12.3	16	4172406
	CA*F4860*6D*+TXV	G*VC950905DXA*	46,000	35,000	12.3	16	4172405
CA*F4860*6D*+TXV	G*VC950704CXA*	45,500	34,600	12	15	4172404	
CA*F4860*6D*+TXV	G*VC90905DXA*	46,000	35,000	12.3	16	4172403	

See Notes on Page 45.

AHRI PERFORMANCE DATA (CONT.)

OUTDOOR UNIT	INDOOR UNITS		COOLING CAPACITY (BTU/H)		SEER ¹	EER ²	AHRI #
	COIL/AIR HANDLER	FURNACE/BLOWER	TOTAL	SENSIBLE			
ASXC16 0481B* (cont.)	CA*F4860*6D*+TXV	G*VC90704CXA*	45,500	34,600	12	15	4172402
	CA*F4860*6D*+TXV	G*VC81155CXA*	46,000	35,000	12	16	4172401
	CA*F4860*6D*+TXV	G*VC80905CXA*	46,000	35,000	12.3	16	4172400
	CA*F4860*6D*+TXV	G*VC80704BXA*	45,500	34,600	12	15	4172399
	CA*F4860*6D*+TXV	A*VC951155DXA*	46,000	35,000	12.5	16	4172398
	CA*F4860*6D*+TXV	A*VC950905DXA*	46,000	35,000	12.3	16	4172397
	CA*F4860*6D*+TXV	A*VC950704CXA*	45,500	34,600	12	15	4172396
	CA*F4860*6D*+TXV	A*VC90905DXA*	46,000	35,000	12.3	16	4172395
	CA*F4860*6D*+TXV	A*VC90704CXA*	45,500	34,600	12	15	4172394
	CA*F4860*6D*+TXV	A*VC81155CXA*	46,000	35,000	12	16	4172393
	CA*F4860*6D*+TXV	A*VC80905CXA*	46,000	35,000	12.3	16	4172392
	CA*F4860*6D*+TXV	A*VC80704BXA*	45,500	34,600	12	15	4172391
	CA*F4961*6A*+TXV	G*VC951155DXA*	47,000	35,700	12.5	16	4172424
	CA*F4961*6A*+TXV	G*VC950905DXA*	47,000	35,700	12.5	16	4172423
	CA*F4961*6A*+TXV	G*VC950704CXA*	46,500	35,300	12	15	4172422
	CA*F4961*6A*+TXV	G*VC90905DXA*	47,000	35,700	12.5	16	4172421
	CA*F4961*6A*+TXV	G*VC90704CXA*	46,500	35,300	12	15	4172420
	CA*F4961*6A*+TXV	G*VC81155CXA*	46,500	35,300	12	16	4172419
	CA*F4961*6A*+TXV	G*VC80905CXA*	47,000	35,700	12.5	16	4172418
	CA*F4961*6A*+TXV	G*VC80704BXA*	46,000	35,000	12.3	15.5	4172417
	CA*F4961*6A*+TXV	A*VC951155DXA*	47,000	35,700	12.5	16	4172416
	CA*F4961*6A*+TXV	A*VC950905DXA*	47,000	35,700	12.5	16	4172415
	CA*F4961*6A*+TXV	A*VC950704CXA*	46,500	35,300	12	15	4172414
	CA*F4961*6A*+TXV	A*VC90905DXA*	47,000	35,700	12.5	16	4172413
	CA*F4961*6A*+TXV	A*VC90704CXA*	46,500	35,300	12	15	4172412
	CA*F4961*6A*+TXV	A*VC81155CXA*	46,500	35,300	12	16	4172411
	CA*F4961*6A*+TXV	A*VC80905CXA*	47,000	35,700	12.5	16	4172410
	CA*F4961*6A*+TXV	A*VC80704BXA*	46,000	35,000	12.3	15.5	4172409
	CA*F4961*6A*+TXV	MBVC2000**-1A*	47,000	35,700	12.5	16	4172408
	CA*F4961*6A*+TXV	MBVC1600**-1A*	46,000	35,000	12	15	4172407
	CA*F4961*6D*+TXV	G*VC951155DXA*	47,000	35,700	12.5	16	4431438
	CA*F4961*6D*+TXV	G*VC950905DXA*	47,000	35,700	12.5	16	4431437
	CA*F4961*6D*+TXV	G*VC950704CXA*	46,500	35,300	12	15	4431436
	CA*F4961*6D*+TXV	G*VC90905DXA*	47,000	35,700	12.5	16	4431435
	CA*F4961*6D*+TXV	G*VC90704CXA*	46,500	35,300	12	15	4431434
	CA*F4961*6D*+TXV	G*VC81155CXA*	46,500	35,300	12	16	4431433
	CA*F4961*6D*+TXV	G*VC80905CXA*	47,000	35,700	12.5	16	4431432
	CA*F4961*6D*+TXV	G*VC80704BXA*	46,000	35,000	12.3	15.5	4431431
	CA*F4961*6D*+TXV	A*VC951155DXA*	47,000	35,700	12.5	16	4431430
	CA*F4961*6D*+TXV	A*VC950905DXA*	47,000	35,700	12.5	16	4431429
	CA*F4961*6D*+TXV	A*VC950704CXA*	46,500	35,300	12	15	4431428
	CA*F4961*6D*+TXV	A*VC90905DXA*	47,000	35,700	12.5	16	4431427
CA*F4961*6D*+TXV	A*VC90704CXA*	46,500	35,300	12	15	4431426	
CA*F4961*6D*+TXV	A*VC81155CXA*	46,500	35,300	12	16	4431425	
CA*F4961*6D*+TXV	A*VC80905CXA*	47,000	35,700	12.5	16	4431424	
CA*F4961*6D*+TXV	A*VC80704BXA*	46,000	35,000	12.3	15.5	4431423	
CA*F4961*6D*+TXV	MBVC2000**-1A*	47,000	35,700	12.5	16	4431407	
CA*F4961*6D*+TXV	MBVC1600**-1A*	46,000	35,000	12	15	4431406	
CHPF4860D6D*+TXV	G*VC951155DXA*	47,000	35,700	12.3	16	4172442	

See Notes on Page 45.

AHRI PERFORMANCE DATA (CONT.)

OUTDOOR UNIT	INDOOR UNITS		COOLING CAPACITY (BTU/H)		SEER ¹	EER ²	AHRI #
	COIL/AIR HANDLER	FURNACE/BLOWER	TOTAL	SENSIBLE			
ASXC16 0481B* (cont.)	CHPF4860D6D*+TXV	G*VC950905DXA*	47,000	35,700	12.3	16	4172441
	CHPF4860D6D*+TXV	G*VC950704CXA*	46,000	35,000	12	15.5	4172440
	CHPF4860D6D*+TXV	G*VC90905DXA*	47,000	35,700	12.3	16	4172439
	CHPF4860D6D*+TXV	G*VC90704CXA*	46,000	35,000	12	15.5	4172438
	CHPF4860D6D*+TXV	G*VC81155CXA*	45,500	34,600	12	15.5	4172437
	CHPF4860D6D*+TXV	G*VC80905CXA*	45,500	34,600	12	15.5	4172436
	CHPF4860D6D*+TXV	G*VC80704BXA*	45,500	34,600	12	15.5	4172435
	CHPF4860D6D*+TXV	A*VC951155DXA*	47,000	35,700	12.3	16	4172434
	CHPF4860D6D*+TXV	A*VC950905DXA*	47,000	35,700	12.3	16	4172433
	CHPF4860D6D*+TXV	A*VC950704CXA*	46,000	35,000	12	15.5	4172432
	CHPF4860D6D*+TXV	A*VC90905DXA*	47,000	35,700	12.3	16	4172431
	CHPF4860D6D*+TXV	A*VC90704CXA*	46,000	35,000	12	15.5	4172430
	CHPF4860D6D*+TXV	A*VC81155CXA*	45,500	34,600	12	15.5	4172429
	CHPF4860D6D*+TXV	A*VC80905CXA*	45,500	34,600	12	15.5	4172428
	CHPF4860D6D*+TXV	A*VC80704BXA*	45,500	34,600	12	15.5	4172427
	CHPF4860D6D*+TXV	MBVC2000** -1A*	47,000	35,700	12.5	16	4172426
	CHPF4860D6D*+TXV	MBVC1600** -1A*	46,000	35,000	12	15	4172425
	CSCF4860N6C*+TXV	A*VC951155DXA*	46,000	35,000	12.5	16	4172450
	CSCF4860N6C*+TXV	A*VC950905DXA*	46,000	35,000	12.5	16	4172449
	CSCF4860N6C*+TXV	A*VC950704CXA*	45,500	34,600	12	15	4172448
	CSCF4860N6C*+TXV	A*VC90905DXA*	46,000	35,000	12.5	16	4172447
	CSCF4860N6C*+TXV	A*VC90704CXA*	45,500	34,600	12	15	4172446
	CSCF4860N6C*+TXV	A*VC81155CXA*	46,000	35,000	12	15.5	4172445
	CSCF4860N6C*+TXV	A*VC80905CXA*	47,000	35,700	12.3	16	4172444
CSCF4860N6C*+TXV	A*VC80704BXA*	45,500	34,600	12	15.5	4172443	
ASXC16 0601A*	AEPF426016C*+TXV		57,000	43,300	15.5	11.5	3610559
	AVPTC426014A*		57,000	43,300	15.5	11.5	4431354
	CA*F4860*6B*+TXV	G*VC950905CXA*	57,500	43,700	15.0	11.5	4200688
	CA*F4860*6B*+TXV	A*VC950905CXA*	57,500	43,700	15.0	11.5	4200686
	CA*F4860*6B*+TXV	G*VC950915DXA*	57,500	43,700	15.0	11.5	4200023
	CA*F4860*6B*+TXV	A*VC950915DXA*	57,500	43,700	15.0	11.5	4200021
	CA*F4860*6B*+TXV	A*VC80905CXA*	57,000	43,300	15.5	11.5	3642673
	CA*F4860*6B*+TXV	A*VC81155CXA*	56,000	42,600	15.0	11.2	3642659
	CA*F4860*6B*+TXV	MBE2000** -1B*	57,000	43,300	16.0	12.0	3610667
	CA*F4860*6B*+TXV	MBVC2000** -1A*	57,000	43,300	16.0	12.0	3610617
	CA*F4860*6B*+TXV	G*VC951155DXA*	57,500	43,700	15.5	11.5	3610582
	CA*F4860*6B*+TXV	G*VC950905DXA*	57,500	43,700	15.5	11.5	3610581
	CA*F4860*6B*+TXV	G*V951155D**	57,500	43,700	15.5	11.5	3610580
	CA*F4860*6B*+TXV	G*V950905D**	57,500	43,700	15.5	11.5	3610579
	CA*F4860*6B*+TXV	A*VC951155DXA*	57,500	43,700	15.5	11.5	3610578
	CA*F4860*6B*+TXV	A*VC950905DXA*	57,500	43,700	15.5	11.5	3610577
	CA*F4860*6B*+TXV	A*VC90905DXA*	57,500	43,700	15.5	11.5	3610576
	CA*F4860*6B*+TXV	A*V91155D**	57,500	43,700	15.5	11.5	3610575
	CA*F4860*6B*+TXV	A*V90905D**	57,500	43,700	15.5	11.5	3610574
	CA*F4860*6B*+TXV	A*V80905C**	57,000	43,300	15.5	11.5	3610560
	CA*F4860*6B*+TXV	A*V81155C**	56,000	42,600	15.0	12.0	3610546
	CA*F4860*6D*+TXV	G*VC950905CXA*	57,500	43,700	15.0	11.5	4200691
	CA*F4860*6D*+TXV	A*VC950905CXA*	57,500	43,700	15.0	11.5	4200690
	CA*F4860*6D*+TXV	G*VC950915DXA*	57,500	43,700	15.0	11.5	4200027

See Notes on Page 45.

AHRI PERFORMANCE DATA (CONT.)

OUTDOOR UNIT	INDOOR UNITS		COOLING CAPACITY (BTU/H)		SEER ¹	EER ²	AHRI #
	COIL/AIR HANDLER	FURNACE/BLOWER	TOTAL	SENSIBLE			
ASXC16 0601A* (cont.)	CA*F4860*6D*+TXV	A*VC950915DXA*	57,500	43,700	15.0	11.5	4200024
	CA*F4860*6D*+TXV	G*VC951155DXA*	57,500	43,700	15.5	11.5	3881427
	CA*F4860*6D*+TXV	G*VC950905DXA*	57,500	43,700	15.5	11.5	3881426
	CA*F4860*6D*+TXV	G*V951155DXA*	57,500	43,700	15.5	11.5	3881425
	CA*F4860*6D*+TXV	G*V950905DXA*	57,500	43,700	15.5	11.5	3881424
	CA*F4860*6D*+TXV	A*VC951155DXA*	57,500	43,700	15.5	11.5	3881423
	CA*F4860*6D*+TXV	A*VC950905DXA*	57,500	43,700	15.5	11.5	3881422
	CA*F4860*6D*+TXV	A*VC90905DXA*	57,500	43,700	15.5	11.5	3881421
	CA*F4860*6D*+TXV	A*VC81155CXA*	56,000	42,600	15.0	11.2	3881420
	CA*F4860*6D*+TXV	A*VC80905CXA*	57,000	43,300	15.5	11.5	3881419
	CA*F4860*6D*+TXV	A*V91155DX**	57,500	43,700	15.5	11.5	3881418
	CA*F4860*6D*+TXV	A*V90905DX**	57,500	43,700	15.5	11.5	3881417
	CA*F4860*6D*+TXV	A*V81155CX**	56,000	42,600	15.0	12.0	3881416
	CA*F4860*6D*+TXV	A*V80905CX**	57,000	43,300	15.5	11.5	3881415
	CA*F4860*6D*+TXV	MBVC2000** -1A*	57,000	43,300	16.0	12.0	3881373
	CA*F4860*6D*+TXV	MBE2000** -1B*	57,000	43,300	16.0	12.0	3881369
	CA*F4961*6A*+TXV	G*VC950915DXA*	57,500	43,700	15.5	11.5	4594838
	CA*F4961*6A*+TXV	A*VC950905CXA*	57,500	43,700	15.5	11.5	4200693
	CA*F4961*6A*+TXV	A*VC950915DXA*	57,500	43,700	15.5	11.5	4200028
	CA*F4961*6A*+TXV	A*VC80905CXA*	57,000	43,300	15.5	11.5	3642674
	CA*F4961*6A*+TXV	A*VC81155CXA*	56,000	42,600	15.5	11.5	3642660
	CA*F4961*6A*+TXV	MBE2000** -1B*	57,000	43,300	16.0	12.0	3610668
	CA*F4961*6A*+TXV	MBVC2000** -1A*	57,000	43,300	16.0	12.0	3610618
	CA*F4961*6A*+TXV	A*VC951155DXA*	57,500	43,700	15.5	11.5	3610587
	CA*F4961*6A*+TXV	A*VC950905DXA*	57,500	43,700	15.5	11.5	3610586
	CA*F4961*6A*+TXV	A*VC90905DXA*	57,500	43,700	15.5	11.5	3610585
	CA*F4961*6A*+TXV	A*V91155D**	57,500	43,700	15.5	11.5	3610584
	CA*F4961*6A*+TXV	A*V90905D**	57,500	43,700	15.5	11.5	3610583
	CA*F4961*6A*+TXV	A*V80905C**	57,000	43,300	15.5	11.5	3610561
	CA*F4961*6A*+TXV	A*V81155C**	56,000	42,600	15.5	12.0	3610547
	CA*F4961*6D*+TXV	A*VC951155DXA*	57,500	43,700	15.5	11.5	4431444
	CA*F4961*6D*+TXV	A*VC950905DXA*	57,500	43,700	15.5	11.5	4431443
	CA*F4961*6D*+TXV	A*VC950905CXA*	57,500	43,700	15.5	11.5	4431442
	CA*F4961*6D*+TXV	A*VC90905DXA*	57,500	43,700	15.5	11.5	4431441
	CA*F4961*6D*+TXV	A*VC81155CXA*	56,000	42,600	15.5	11.5	4431440
	CA*F4961*6D*+TXV	A*VC80905CXA*	57,000	43,300	15.5	11.5	4431439
	CA*F4961*6D*+TXV	MBVC2000** -1A*	57,000	43,300	16.0	12.0	4431408
	CHPF4860D6D*+TXV	G*VC950915DXA*	57,000	43,300	15.5	11.5	4594839
	CHPF4860D6D*+TXV	A*VC950905CXA*	57,000	43,300	15.5	11.5	4200695
	CHPF4860D6D*+TXV	A*VC950915DXA*	57,000	43,300	15.5	11.5	4200030
	CHPF4860D6D*+TXV	G*VC81155CXA*	56,000	42,600	15.5	11.5	3642669
	CHPF4860D6D*+TXV	G*VC80905CXA*	56,000	42,600	15.5	11.5	3642667
CHPF4860D6D*+TXV	A*VC81155CXA*	56,000	42,600	15.5	11.5	3642661	
CHPF4860D6D*+TXV	A*VC80905CXA*	56,000	42,600	15.5	12.0	3642648	
CHPF4860D6D*+TXV	MBVC2000** -1A*	57,000	43,300	16.0	12.0	3610619	
CHPF4860D6D*+TXV	A*VC951155DXA*	57,000	43,300	15.5	11.5	3610567	
CHPF4860D6D*+TXV	A*VC950905DXA*	57,000	43,300	15.5	12.5	3610566	
CHPF4860D6D*+TXV	A*VC90905DXA*	57,000	43,300	15.5	12.5	3610565	
CHPF4860D6D*+TXV	A*V91155D**	57,000	43,300	15.5	11.5	3610564	

See Notes on Page 45.

AHRI PERFORMANCE DATA (CONT.)

OUTDOOR UNIT	INDOOR UNITS		COOLING CAPACITY (BTU/H)		SEER ¹	EER ²	AHRI #
	COIL/AIR HANDLER	FURNACE/BLOWER	TOTAL	SENSIBLE			
ASXC16 0601A* (cont.)	CHPF4860D6D*+TXV	A*V90905D**	57,000	43,300	15.5	12.5	3610563
	CHPF4860D6D*+TXV	MBE2000** -1B*	57,000	43,300	16.0	12.0	3610562
	CHPF4860D6D*+TXV	G*V81155C**	56,000	42,600	15.5	11.5	3610553
	CHPF4860D6D*+TXV	G*V80905C**	56,000	42,600	15.5	12.0	3610552
	CHPF4860D6D*+TXV	A*V81155C**	56,000	42,600	15.5	11.5	3610551
	CHPF4860D6D*+TXV	A*V80905C**	56,000	42,600	15.5	12.0	3610550
	CSCF4860N6C*+TXV	G*VC950915DXA*	57,000	43,300	15.5	11.5	4594840
	CSCF4860N6C*+TXV	A*VC950905CXA*	57,000	43,300	15.5	11.5	4200697
	CSCF4860N6C*+TXV	A*VC950915DXA*	57,000	43,300	15.5	11.5	4200032
	CSCF4860N6C*+TXV	A*VC80905CXA*	57,000	43,300	15.5	11.5	3642675
	CSCF4860N6C*+TXV	A*VC81155CXA*	56,000	42,600	15.5	11.5	3642662
	CSCF4860N6C*+TXV	A*VC951155DXA*	57,000	43,300	15.5	11.5	3610573
	CSCF4860N6C*+TXV	A*VC950905DXA*	57,000	43,300	15.5	11.5	3610572
	CSCF4860N6C*+TXV	A*VC90905DXA*	57,000	43,300	15.5	11.5	3610571
	CSCF4860N6C*+TXV	A*V91155D**	57,000	43,300	15.5	11.5	3610570
	CSCF4860N6C*+TXV	A*V90905D**	57,000	43,300	15.5	11.5	3610569
	CSCF4860N6C*+TXV	A*V80905C**	57,000	43,300	15.5	11.5	3610568
CSCF4860N6C*+TXV	A*V81155C**	56,000	42,600	15.5	11.5	3610556	
ASXC16 0601B*	AEPF426016C*+TXV		57,000	43,300	15.5	12.3	3798677
	AVPTC426014A*		57,000	43,300	15.5	12.3	4431355
	CA*F4860*6B*+TXV	G*VC950905CXA*	55,500	42,200	15.0	11.5	4200701
	CA*F4860*6B*+TXV	A*VC950905CXA*	55,500	42,200	15.0	11.5	4200699
	CA*F4860*6B*+TXV	G*VC950915DXA*	55,500	42,200	15.0	11.5	4200036
	CA*F4860*6B*+TXV	A*VC950915DXA*	55,500	42,200	15.0	11.5	4200034
	CA*F4860*6B*+TXV	MBVC2000** -1A*	55,500	42,200	15.5	12.0	3798679
	CA*F4860*6B*+TXV	MBE2000** -1B*	56,000	42,600	15.5	12.3	3798678
	CA*F4860*6B*+TXV	G*VC951155DXA*	55,500	42,200	15.5	12.0	3798673
	CA*F4860*6B*+TXV	G*VC950905DXA*	55,500	42,200	15.5	12.0	3798669
	CA*F4860*6B*+TXV	G*VC91155DXA*	55,500	42,200	15.5	12.0	3798667
	CA*F4860*6B*+TXV	G*VC90905DXA*	55,500	42,200	15.5	12.0	3798664
	CA*F4860*6B*+TXV	G*V951155D**	55,500	42,200	15.5	12.0	3798658
	CA*F4860*6B*+TXV	G*V950905D**	55,500	42,200	15.5	12.0	3798654
	CA*F4860*6B*+TXV	G*V91155D**	55,500	42,200	15.0	12.0	3798652
	CA*F4860*6B*+TXV	G*V90905D**	55,500	42,200	15.5	12.0	3798649
	CA*F4860*6B*+TXV	A*VC951155DXA*	55,500	42,200	15.5	12.0	3798641
	CA*F4860*6B*+TXV	A*VC950905DXA*	55,500	42,200	15.5	12.0	3798637
	CA*F4860*6B*+TXV	A*VC90905DXA*	55,500	42,200	15.5	12.0	3798633
	CA*F4860*6B*+TXV	A*VC81155CXA*	55,500	42,200	15.5	12.0	3798629
	CA*F4860*6B*+TXV	A*VC80905CXA*	55,500	42,200	15.5	12.0	3798625
	CA*F4860*6B*+TXV	A*V91155D**	55,500	42,200	15.0	12.0	3798621
	CA*F4860*6B*+TXV	A*V90905D**	55,500	42,200	15.5	12.0	3798617
	CA*F4860*6B*+TXV	A*V81155C**	55,500	42,200	15.5	12.0	3798613
	CA*F4860*6B*+TXV	A*V80905C**	55,500	42,200	15.5	12.0	3798609
	CA*F4860*6D*+TXV	G*VC950905CXA*	55,500	42,200	15.0	11.5	4200705
	CA*F4860*6D*+TXV	A*VC950905CXA*	55,500	42,200	15.0	11.5	4200703
	CA*F4860*6D*+TXV	G*VC950915DXA*	55,500	42,200	15.0	11.5	4200040
	CA*F4860*6D*+TXV	A*VC950915DXA*	55,500	42,200	15.0	11.5	4200038
	CA*F4860*6D*+TXV	G*VC951155DXA*	55,500	42,200	15.5	12.0	3881444
CA*F4860*6D*+TXV	G*VC950905DXA*	55,500	42,200	15.5	12.0	3881443	
CA*F4860*6D*+TXV	G*VC91155DXA*	55,500	42,200	15.5	12.0	3881442	
CA*F4860*6D*+TXV	G*VC90905DXA*	55,500	42,200	15.5	12.0	3881441	

See Notes on Page 45.

AHRI PERFORMANCE DATA (CONT.)

OUTDOOR UNIT	INDOOR UNITS		COOLING CAPACITY (BTU/H)		SEER ¹	EER ²	AHRI #
	COIL/AIR HANDLER	FURNACE/BLOWER	TOTAL	SENSIBLE			
ASXC16 0601B* (cont.)	CA*F4860*6D*+TXV	G*V951155DXA*	55,500	42,200	15.5	12.0	3881440
	CA*F4860*6D*+TXV	G*V950905DXA*	55,500	42,200	15.5	12.0	3881439
	CA*F4860*6D*+TXV	G*V91155D**	55,500	42,200	15.0	12.0	3881438
	CA*F4860*6D*+TXV	G*V90905D**	55,500	42,200	15.5	12.0	3881437
	CA*F4860*6D*+TXV	A*VC951155DXA*	55,500	42,200	15.5	12.0	3881436
	CA*F4860*6D*+TXV	A*VC950905DXA*	55,500	42,200	15.5	12.0	3881435
	CA*F4860*6D*+TXV	A*VC90905DXA*	55,500	42,200	15.5	12.0	3881434
	CA*F4860*6D*+TXV	A*VC81155CXA*	55,500	42,200	15.5	12.0	3881433
	CA*F4860*6D*+TXV	A*VC80905CXA*	55,500	42,200	15.5	12.0	3881432
	CA*F4860*6D*+TXV	A*V91155DX**	55,500	42,200	15.0	12.0	3881431
	CA*F4860*6D*+TXV	A*V90905DX**	55,500	42,200	15.5	12.0	3881430
	CA*F4860*6D*+TXV	A*V81155CX**	55,500	42,200	15.5	12.0	3881429
	CA*F4860*6D*+TXV	A*V80905CX**	55,500	42,200	15.5	12.0	3881428
	CA*F4860*6D*+TXV	MBVC2000**-1A*	55,500	42,200	15.5	12.0	3881374
	CA*F4860*6D*+TXV	MBE2000**-1B*	56,000	42,600	15.5	12.3	3881370
	CA*F4961*6A*+TXV	G*VC950905CXA*	56,000	42,600	15.5	11.5	4200709
	CA*F4961*6A*+TXV	A*VC950905CXA*	56,000	42,600	15.5	11.5	4200707
	CA*F4961*6A*+TXV	G*VC950915DXA*	56,000	42,600	15.5	11.5	4200044
	CA*F4961*6A*+TXV	A*VC950915DXA*	56,000	42,600	15.5	11.5	4200042
	CA*F4961*6A*+TXV	G*E81155C**	56,000	42,600	15.0	11.5	3798688
	CA*F4961*6A*+TXV	G*E80905C**	56,000	42,600	15.0	11.5	3798687
	CA*F4961*6A*+TXV	MBVC2000**-1A*	57,000	43,300	16.0	12.3	3798681
	CA*F4961*6A*+TXV	MBE2000**-1B*	57,000	43,300	16.0	12.3	3798680
	CA*F4961*6A*+TXV	G*VC951155DXA*	56,000	42,600	15.5	12.0	3798674
	CA*F4961*6A*+TXV	G*VC950905DXA*	56,000	42,600	15.5	12.3	3798670
	CA*F4961*6A*+TXV	G*VC91155DXA*	56,000	42,600	15.5	12.0	3798668
	CA*F4961*6A*+TXV	G*VC90905DXA*	56,000	42,600	15.5	12.3	3798665
	CA*F4961*6A*+TXV	G*V951155D**	56,000	42,600	15.5	12.0	3798659
	CA*F4961*6A*+TXV	G*V950905D**	56,000	42,600	15.5	12.3	3798655
	CA*F4961*6A*+TXV	G*V91155D**	56,000	42,600	15.0	12.0	3798653
	CA*F4961*6A*+TXV	G*V90905D**	56,000	42,600	15.5	12.3	3798650
	CA*F4961*6A*+TXV	A*VC951155DXA*	56,000	42,600	15.5	12.0	3798642
	CA*F4961*6A*+TXV	A*VC950905DXA*	56,000	42,600	15.5	12.3	3798638
	CA*F4961*6A*+TXV	A*VC90905DXA*	56,000	42,600	15.5	12.3	3798634
	CA*F4961*6A*+TXV	A*VC81155CXA*	56,000	42,600	15.5	12.0	3798630
	CA*F4961*6A*+TXV	A*VC80905CXA*	56,000	42,600	15.5	12.3	3798626
	CA*F4961*6A*+TXV	A*V91155D**	56,000	42,600	15.5	12.0	3798622
	CA*F4961*6A*+TXV	A*V90905D**	56,000	42,600	15.5	12.3	3798618
	CA*F4961*6A*+TXV	A*V81155C**	56,000	42,600	15.5	12.0	3798614
	CA*F4961*6A*+TXV	A*V80905C**	56,000	42,600	15.5	12.3	3798610
	CA*F4961*6D*+TXV	G*VC951155DXA*	56,000	42,600	15.5	12.0	4431457
	CA*F4961*6D*+TXV	G*VC950905DXA*	56,000	42,600	15.5	12.3	4431456
	CA*F4961*6D*+TXV	G*VC950905CXA*	56,000	42,600	15.5	11.5	4431455
	CA*F4961*6D*+TXV	G*VC91155DXA*	56,000	42,600	15.5	12.0	4431454
CA*F4961*6D*+TXV	G*VC90905DXA*	56,000	42,600	15.5	12.3	4431453	
CA*F4961*6D*+TXV	G*E81155C**	56,000	42,600	15.0	11.5	4431452	
CA*F4961*6D*+TXV	G*E80905C**	56,000	42,600	15.0	11.5	4431451	
CA*F4961*6D*+TXV	A*VC951155DXA*	56,000	42,600	15.5	12.0	4431450	
CA*F4961*6D*+TXV	A*VC950905DXA*	56,000	42,600	15.5	12.3	4431449	
CA*F4961*6D*+TXV	A*VC950905CXA*	56,000	42,600	15.5	11.5	4431448	
CA*F4961*6D*+TXV	A*VC90905DXA*	56,000	42,600	15.5	12.3	4431447	

See Notes on Page 45.

AHRI PERFORMANCE DATA (CONT.)

OUTDOOR UNIT	INDOOR UNITS		COOLING CAPACITY (BTU/H)		SEER ¹	EER ²	AHRI #
	COIL/AIR HANDLER	FURNACE/BLOWER	TOTAL	SENSIBLE			
ASXC16 0601B* (cont.)	CA*F4961*6D*+TXV	A*VC81155CXA*	56,000	42,600	15.5	12.0	4431446
	CA*F4961*6D*+TXV	A*VC80905CXA*	56,000	42,600	15.5	12.3	4431445
	CA*F4961*6D*+TXV	MBVC2000**-1A*	57,000	43,300	16.0	12.3	4431409
	CHPF4860D6D*+TXV	G*VC950905CXA*	56,000	42,600	15.5	11.5	4200712
	CHPF4860D6D*+TXV	A*VC950905CXA*	56,000	42,600	15.5	11.5	4200710
	CHPF4860D6D*+TXV	G*VC950915DXA*	56,000	42,600	15.5	11.5	4200047
	CHPF4860D6D*+TXV	A*VC950915DXA*	56,000	42,600	15.5	11.5	4200045
	CHPF4860D6D*+TXV	MBVC2000**-1A*	57,000	43,300	15.5	12.3	3798683
	CHPF4860D6D*+TXV	MBE2000**-1B*	57,000	43,300	15.5	12.3	3798682
	CHPF4860D6D*+TXV	G*VC951155DXA*	56,000	42,600	15.5	12.0	3798675
	CHPF4860D6D*+TXV	G*VC950905DXA*	56,000	42,600	15.5	12.3	3798671
	CHPF4860D6D*+TXV	G*VC90905DXA*	56,000	42,600	15.5	12.3	3798666
	CHPF4860D6D*+TXV	G*VC81155CXA*	56,000	42,600	15.5	12.0	3798663
	CHPF4860D6D*+TXV	G*VC80905CXA*	56,000	42,600	15.5	12.3	3798662
	CHPF4860D6D*+TXV	G*V951155D**	56,000	42,600	15.5	12.0	3798660
	CHPF4860D6D*+TXV	G*V950905D**	56,000	42,600	15.5	12.3	3798656
	CHPF4860D6D*+TXV	G*V90905D**	56,000	42,600	16.0	12.3	3798651
	CHPF4860D6D*+TXV	G*V81155C**	56,000	42,600	15.5	12.0	3798648
	CHPF4860D6D*+TXV	G*V80905C**	56,000	42,600	15.5	12.3	3798647
	CHPF4860D6D*+TXV	G*E81155C**	56,000	42,600	15.0	11.5	3798646
	CHPF4860D6D*+TXV	G*E80905C**	56,000	42,600	15.0	11.5	3798645
	CHPF4860D6D*+TXV	A*VC951155DXA*	56,000	42,600	15.5	12.0	3798643
	CHPF4860D6D*+TXV	A*VC950905DXA*	56,000	42,600	15.5	12.3	3798639
	CHPF4860D6D*+TXV	A*VC90905DXA*	56,000	42,600	15.5	12.3	3798635
	CHPF4860D6D*+TXV	A*VC81155CXA*	56,000	42,600	15.5	12.0	3798631
	CHPF4860D6D*+TXV	A*VC80905CXA*	56,000	42,600	15.5	12.3	3798627
	CHPF4860D6D*+TXV	A*V91155D**	56,000	42,600	15.5	12.0	3798623
	CHPF4860D6D*+TXV	A*V90905D**	56,000	42,600	15.5	12.3	3798619
	CHPF4860D6D*+TXV	A*V81155C**	56,000	42,600	15.5	12.0	3798615
	CHPF4860D6D*+TXV	A*V80905C**	56,000	42,600	15.5	12.3	3798611
	CSCF4860N6C*+TXV	G*VC950905CXA*	56,000	42,600	15.5	11.5	4200716
	CSCF4860N6C*+TXV	A*VC950905CXA*	56,000	42,600	15.5	11.5	4200714
	CSCF4860N6C*+TXV	G*VC950915DXA*	56,000	42,600	15.5	11.5	4200051
	CSCF4860N6C*+TXV	A*VC950915DXA*	56,000	42,600	15.5	11.5	4200049
	CSCF4860N6C*+TXV	G*VC951155DXA*	56,000	42,600	15.5	12.0	3798676
	CSCF4860N6C*+TXV	G*VC950905DXA*	56,000	42,600	15.5	12.3	3798672
	CSCF4860N6C*+TXV	G*V951155D**	56,000	42,600	15.5	12.0	3798661
	CSCF4860N6C*+TXV	G*V950905D**	56,000	42,600	15.5	12.3	3798657
	CSCF4860N6C*+TXV	A*VC951155DXA*	56,000	42,600	15.5	12.0	3798644
	CSCF4860N6C*+TXV	A*VC950905DXA*	56,000	42,600	15.5	12.3	3798640
	CSCF4860N6C*+TXV	A*VC90905DXA*	56,000	42,600	15.5	12.3	3798636
	CSCF4860N6C*+TXV	A*VC81155CXA*	56,000	42,600	15.5	12.0	3798632
	CSCF4860N6C*+TXV	A*VC80905CXA*	56,000	42,600	15.5	12.3	3798628
	CSCF4860N6C*+TXV	A*V91155D**	56,000	42,600	15.5	12.0	3798624
	CSCF4860N6C*+TXV	A*V90905D**	56,000	42,600	15.5	12.3	3798620
	CSCF4860N6C*+TXV	A*V81155C**	56,000	42,600	15.5	12.0	3798616
	CSCF4860N6C*+TXV	A*V80905C**	56,000	42,600	15.5	12.3	3798612

¹ Seasonal Energy Efficiency Ratio; Certified per AHRI 210/240 @ 80°F/ 67°F/ 95°F

² Energy Efficiency Ratio @ 80°F/ 67°F/ 95°F

NOTES:

- Always check the S&R plate for electrical data on the UNit being installed.
- When matching the outdoor unit to the indoor unit, use the piston supplied with the outdoor unit or that specified on the piston kit chart supplied with the indoor unit.
- EEP: Order from Service Dept. Part No. B13707-38 or new Solid State Board B13707-35S. Part No. B13707-38 is not interchangeable with B13707-35S. The Goodman Gas Furnace contains the EEP cooling time delay

DIMENSIONS

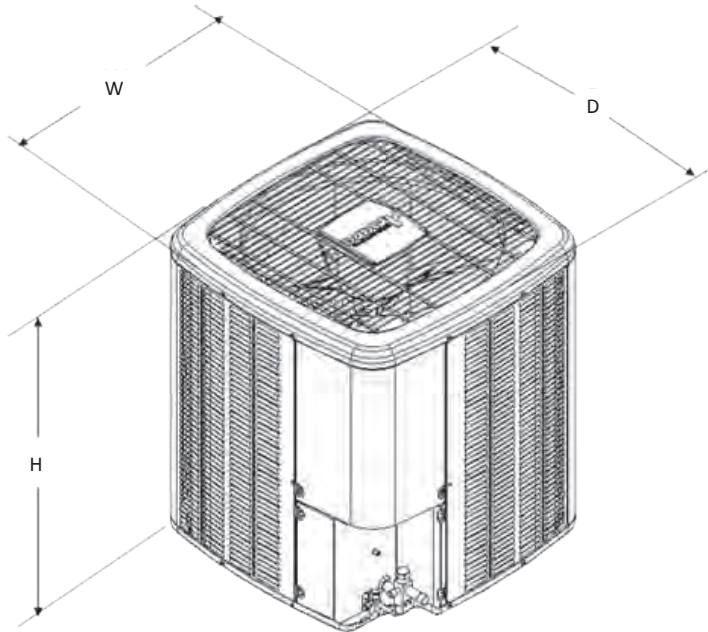

MODEL	DIMENSIONS		
	W"	D"	H"
ASXC160241B*	29	29	32¼
ASXC160361B*	29	29	32¼
ASXC160481A*	35½	35½	38¼
ASXC160481B*	35½	35½	36¼
ASXC160601A*	35½	35½	38¼
ASXC160601B*	35½	35½	38¼

ASXC16 WIRING DIAGRAM

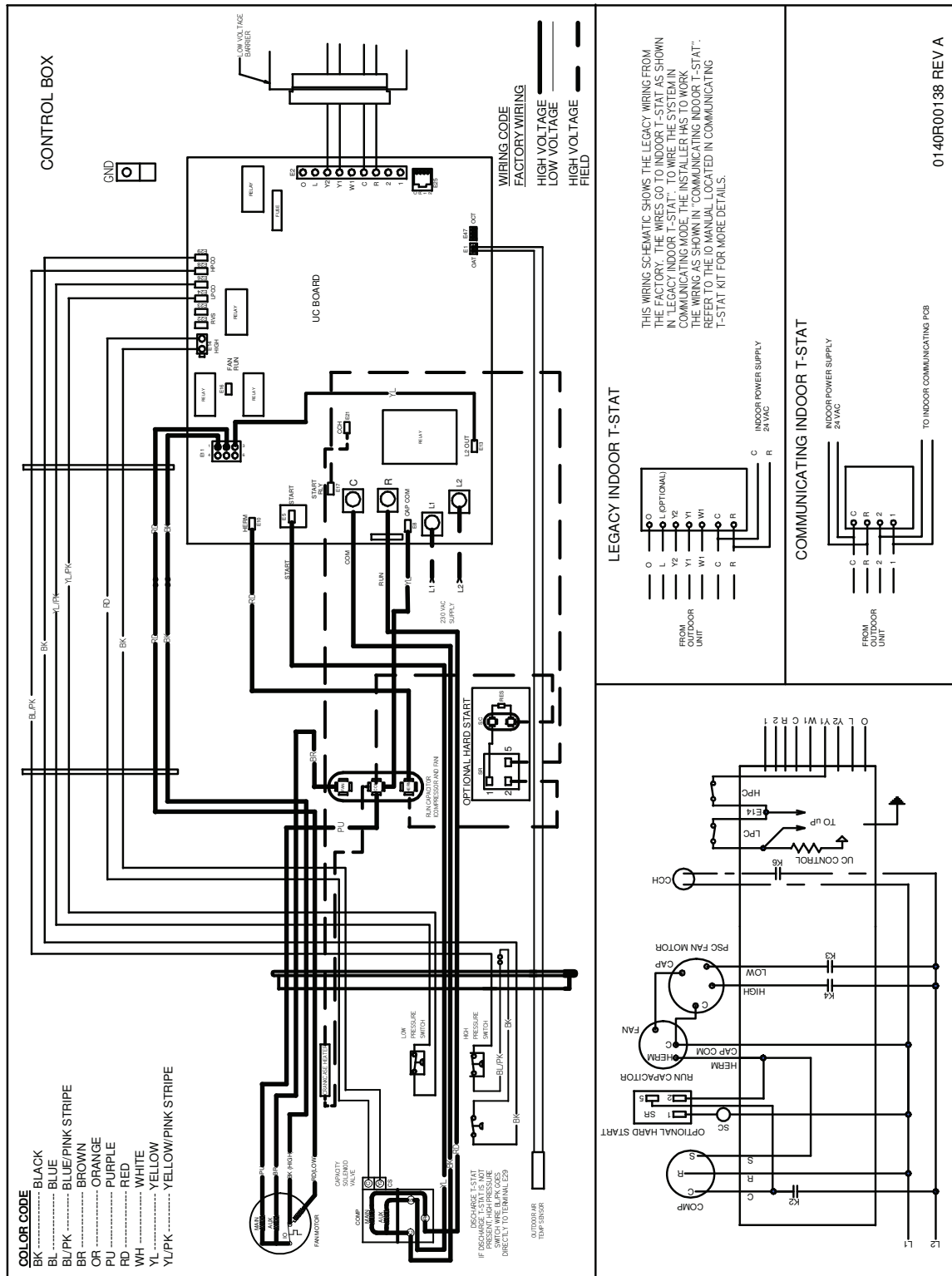

0140R00138 REV A

ACCESSORIES

MODEL	DESCRIPTION	ASXC16 024	ASXC16 036	ASXC16 048	ASXC16 060
ABK-20	Anchor Bracket Kit [^]	X	X	X	X
ASC-01	Anti-Short Cycle Kit	X	X	X	X
B1141643 ¹	24V Transformer	Maximum number installed at the same time is limited. See table below.	Maximum number installed at the same time is limited. See table below.	X	X
CSR-U-1	Hard-start Kit				
CSR-U-2	Hard-start Kit			X	X
CSR-U-3	Hard-start Kit			X	X
FSK01A ²	Freeze Protection Kit			X	X
LSK02A	Liquid Line Solenoid Valve			X	X
OT18-60A ³	Outdoor Thermostat/Lockout Thermostat			X	X
TX2N4 ⁴	TXV Kit				
TX2N4A ⁴	TXV Kit	X			
TX3N4 ⁴	TXV Kit		X		
TX5N4	TXV Kit			X	X

[^] Contains 20 brackets; four brackets needed to anchor unit to pad

¹ This component is included in the CTK01AA communicating thermostat kit.

² Installed on indoor coil

³ Available in 24V legacy mode only. This feature is integrated in the communicating mode.

⁴ Field-installed, non-bleed, expansion valve kit — Condensing units and heat pumps with reciprocating compressors require the use of start-assist components when used in conjunction with an indoor coil using a non-bleed thermal expansion valve refrigerant metering device or liquid line solenoid kit The TXV should always be sized based on the tonnage of the outdoor unit.

MODEL	DESCRIPTION	ASXC16 024	ASXC16 024	ASXC16 024	ASXC16 024	ASXC16 024
B1141643 ¹	24V Transformer			X		X
CSR-U-1	Hard-start Kit	X	X	X		
CSR-U-2	Hard-start Kit					
CSR-U-3	Hard-start Kit					
FSK01A ²	Freeze Protection Kit	X	X	X	X	X
LSK02A	Liquid Line Solenoid Valve	X			X	X
OT18-60A ³	Outdoor Thermostat/Lockout Thermostat		X		X	

MODEL	DESCRIPTION	ASXC16 036	ASXC16 036	ASXC16 036	ASXC16 036	ASXC16 036
B1141643 ¹	24V Transformer					X
CSR-U-1	Hard-start Kit	X	X			
CSR-U-2	Hard-start Kit			X		
CSR-U-3	Hard-start Kit					
FSK01A ²	Freeze Protection Kit	X	X		X	X
LSK02A	Liquid Line Solenoid Valve	X			X	X
OT18-60A ³	Outdoor Thermostat/Lockout Thermostat		X		X	

¹ This component is included in the CTK01AA communicating thermostat kit.

² Installed on indoor coil

³ Available in 24V legacy mode only. This feature is integrated in the communicating mode.

